

FIFTH EDITION

# MANUAL OF ENGINEERING DRAWING

British and International Standards

COLIN H. SIMMONS  
DENNIS E. MAGUIRE  
NEIL PHELPS



# Manual of Engineering Drawing

British and International Standards

Fifth Edition

*Colin H. Simmons*

*Dennis E. Maguire*

*Neil Phelps*

IEng MIED



ELSEVIER



Butterworth-Heinemann

An imprint of Elsevier

Butterworth-Heinemann is an imprint of Elsevier  
The Boulevard, Langford Lane, Kidlington, Oxford OX5 1GB, United Kingdom  
50 Hampshire Street, 5th Floor, Cambridge, MA 02139, United States

Copyright © 2020 Elsevier Ltd. All rights reserved.

No part of this publication may be reproduced or transmitted in any form or by any means, electronic or mechanical, including photocopying, recording, or any information storage and retrieval system, without permission in writing from the publisher. Details on how to seek permission, further information about the Publisher's permissions policies and our arrangements with organizations such as the Copyright Clearance Center and the Copyright Licensing Agency, can be found at our website: [www.elsevier.com/permissions](http://www.elsevier.com/permissions).

This book and the individual contributions contained in it are protected under copyright by the Publisher (other than as may be noted herein).

### Notices

Knowledge and best practice in this field are constantly changing. As new research and experience broaden our understanding, changes in research methods, professional practices, or medical treatment may become necessary.

Practitioners and researchers must always rely on their own experience and knowledge in evaluating and using any information, methods, compounds, or experiments described herein. In using such information or methods they should be mindful of their own safety and the safety of others, including parties for whom they have a professional responsibility.

To the fullest extent of the law, neither the Publisher nor the authors, contributors, or editors, assume any liability for any injury and/or damage to persons or property as a matter of products liability, negligence or otherwise, or from any use or operation of any methods, products, instructions, or ideas contained in the material herein.

### Library of Congress Cataloging-in-Publication Data

A catalog record for this book is available from the Library of Congress

### British Library Cataloguing-in-Publication Data

A catalogue record for this book is available from the British Library

ISBN: 978-0-12-818482-0

For information on all Butterworth-Heinemann publications visit our website at <https://www.elsevier.com/books-and-journals>

*Publisher:* Matthew Deans

*Acquisitions Editor:* Brian Guerin

*Editorial Project Manager:* Ana Claudia Garcia

*Production Project Manager:* Sruthi Sathesh

*Cover Designer:* Greg Harris

Typeset by TNQ Technologies



# Preface

When Collin H. Simmons asked me to assist him in preparing the fifth edition of *Manual of Engineering Drawing* after the release of ISO129-1 – Indication of dimensions and tolerances – general principles, I was honored to do so as this was a standard that Colin had been championing its developing over many years. The new rules introduced in this standard have been incorporated within this fifth edition and it also gave us an opportunity to update, revise and elaborate some of the chapters in relation to the latest developments created in the ever-changing world of engineering technology: particularly those made in the fields of technical product documentation and specification, created by the ISO committees TC10 Technical Product Documentation and TC213 Technical Product Specification – the precepts of which are faithfully adhered to in the British Standard BS 8888 published in December, as is this fifth edition.

It also gave us the opportunity to further enhance the manual's content by introducing a new chapter on design for additive manufacture. This chapter basic information on what can be achieved by the various processes used in additive manufacturing and also tips on what to do and not do when designing products. Additive manufacturing technology is developing all the time and this chapter is not intended to be a definitive design guide, the reader should refer to their Additive Manufacturing provider for the latest information on what is possible.

These days, with the capabilities of CAD systems being able to almost automatically construct projections and developments of parts modelled it could be said that the author of a drawing does not necessarily need to know how to do the same using traditional methods in 2D. We disagree and believe that it is essential that engineers understand the principles of construction say to draw an ellipse, helix, cycloid or cams and gears as this gives the engineer a good understanding of geometry which is not necessarily taught extensively today.

All chapters whose contents are related to ISO/BS 8888 have been updated, to reflect current practices in line with the latest ISO developments.

The text that follows covers the basic aspects of engineering drawing practice required by college and university students, and also professional design and drawing office personnel. Applications show how regularly used standards should be applied and interpreted.

Geometrical constructions are a necessary part of engineering design and analysis, and examples of two- and three-dimensional geometry are provided. Practice is invaluable, not only as a means of understanding principles, but in developing the ability to visualize shape and form in three dimensions with a high degree of fluency. It is

sometimes forgotten that not only do designers produce original drawings, but they are also required to read and absorb the content of drawings they receive, without ambiguity.

The section on engineering diagrams has been retrained to stimulate and broaden technological interest and further study and be of value to students engaged on project work. Readers are invited to redraw a selection of the examples given for experience, and also to appreciate the necessity for the insertion and meaning of every line.

In conclusion, may we wish all readers every success in their studies and careers. We hope they will obtain much satisfaction from employment in the absorbing activities related to creative design and considerable pleasure from the construction and presentation of accurately defined engineering drawings incapable of misinterpretation.

**Neil Phelps**

Colin H. Simmons 1923–2019

Sadly, at the time this 5<sup>th</sup> edition was in its final stages of editing, Colin H. Simmons, one of the original authors, unexpectedly passed away. He was a treasured colleague, of many years standing in the field of National and International Standardization. Colin joined the British Standards Institution and the International Standards Organization in 1974. As head of the UK delegation to ISO/TC10 he demonstrated great leadership and became my mentor in 2000 when I joined the world of standardization. His advice and guidance over the years has been invaluable to me. He will be greatly missed by all who had the fortune to work with him.

His passion for this book was unprecedented, he was extremely proud that it has played a part in educating young engineers, the team at Elsevier team and I dedicate this 5<sup>th</sup> edition in his memory.

**Neil Phelps**

# Acknowledgements

The authors wish to express their special thanks to the British Standards Institution, Chiswick High Road, Chiswick, London W4. 4AL for kind permission to reprint extracts from their publications.

We are also grateful to the International Organization for Standardization, Geneva 20, Switzerland, for granting us permission to use extracts from their publications.

We very much appreciate the encouragement and friendly assistance given to us by:

SKF (UK) Ltd

Barber and Colman Ltd

KGB Micros Ltd

Bauer Springs Ltd

Norgen Martonair Ltd

Delphi Diesel Systems

Loctite Holdings Ltd

GKN Screws and Fasteners Ltd

Staefa Control System Ltd

GGB Bearings Technologies

Autodesk Ltd

F S Ratcliffe Ltd

Salterfix Ltd

We would also like to thank:

Brian and Ray for their sheet metal and machine shop examples, models.

Our final thanks go to our Elsevier colleagues – Brian Guerin, Ana Claudia Garcia and Sruthi Satheesh – for the cordial assistance given throughout the preparation of this fifth edition.

# Design office management and organization

1

Every article used in our day-to-day lives will probably have been produced as a result of solutions to a sequence of operations and considerations, namely:

1. Conception
2. Design and analysis
3. Manufacture
4. Verification
5. In-service (maintenance)
6. Disposal.

The initial stage will commence when an original marketable idea is seen to have a possible course of development. The concept will probably be viewed from an artistic and a technological perspective.

The appearance and visual aspects of a product are very important in creating an acceptable good first impression.

The technologist faces the problem of producing a sound, practical, safe design, which complies with the initial specification and can be produced at an economical cost.

During every stage of development there are many progress records to be maintained and kept up to date so that reference to the complete history is available to responsible employees and regulatory bodies.

Historically, various types of drawings, sketches and paintings have been used to convey ideas and information. Now, 3D models, rapid prototypes and animated 3D presentations have become a common way of conveying design intent. However, a good recognizable picture will often remove ambiguity when a project is being discussed and assist in overcoming a possible language barrier.

British Standards are listed in the British Standards Catalog, and the earliest relevant Engineering Standards date back to 1903. Standards were developed to establish suitable dimensions for a range of sizes of metal bars, sheets, nuts, bolts, flanges, etc. following the Industrial Revolution and used by the Engineering Industry. The first British Standard for Engineering Drawing Office Practice published in September 1927 only contained 14 clauses, as follows:

1. Sizes of drawings and tracings, and widths of tracing cloth and paper
2. Position of drawing number, date and name
3. Indication of scale
4. Method of projection
5. Types of line and writing
6. Color of lines
7. Dimension figures
8. Relative importance of dimensions

9. Indication of materials on drawings
10. Various degrees of finish
11. Screw threads
12. Flats and squares
13. Tapers
14. Abbreviations for drawings.

There were also five figures illustrating:

1. Method of projection
2. Types of line
3. Views and sections
4. Screw threads
5. Tapers.

First angle projection was used for the illustrations and the publication was printed on A5 sheets of paper.

During the early days of the Industrial Revolution manufacturers simply compared and copied component dimensions to match those used on the prototype. However, with the introduction of quantity production where components were required to be made at different factory sites, measurement by more precise means was essential. Individual manufacturers developed their own standard methods. Clearly, for the benefit of industry in general a National Standard was vital. Later the more comprehensive British Standard of Limits and Fits was introduced. There are two clear aspects, which are necessary to be considered in the specification of component drawings:

1. The drawing shows the dimensions for the component in three planes. Dimensions of the manufactured component need to be verified because some variation of size in each of the three planes (length, breadth, and thickness) will be unavoidable. The designer's contribution is to provide a Characteristics Specification, which in current jargon is defined as the 'Design Intent Measurand'.
2. The metrologist produces a 'Characteristics Evaluation' which is simply the Measured Value.

The design office is generally regarded as the heart of any manufacturing organization. Products, components, ideas, layouts, or schemes which may be presented by a designer in the form of rough freehand sketches, may be developed stage by stage into working drawings and annotated 3D models by the designer. There is generally very little constructive work which can be done by other departments within the organisation without an approved drawing of some form being available. The drawing is still, quite often, the universal means of communication.

Drawings are made to an accepted Standard, and in the United Kingdom, it is BS 8888, containing normative and informative references to international Standards. These Standards are acknowledged and accepted throughout the world.

The contents of the drawing (and annotated 3D models) are themselves, where applicable, in agreement with separate Standards relating to materials, dimensions, processes, etc. Larger organizations employ Standards engineers who ensure that products conform to British and also international Standards where necessary. Good design is often the product of teamwork where detailed consideration is given to the aesthetic,

economic, ergonomic and technical aspects of a given problem. It is therefore necessary to impose the appropriate Standards at the design stage, since all manufacturing instructions originate from this point.

A perfect drawing communicates an exact requirement, or specification, which cannot be misinterpreted and which may form part of a legal contract between supplier and user.

Engineering drawings can be produced to a good professional Standard if the following points are observed:

- (a) The types of lines used must be of uniform thickness and density.
- (b) Eliminate fancy printing, shading and associated artistry.
- (c) Include on the drawing only the information which is required to ensure accurate clear communication.
- (d) Use only standard symbols and where no other method of specification exist, appropriate abbreviations.
- (e) Ensure that the drawing is correctly dimensioned (adequately but not over-dimensioned) with no unnecessary details.

Remember that care and consideration given to small details make a big contribution toward perfection, but that perfection itself is no small thing. An accurate, well-delineated engineering drawing can give the designer responsible considerable pride and job satisfaction.

The field of activity of the designer may involve the use, or an appreciation, of the following topics.

1. *Company communications* Most companies have their own systems which have been developed over a period of time for the following:
  - (a) internal documentation;
  - (b) numbering of drawings and contracts;
  - (c) coding of parts and assemblies;
  - (d) production planning for component manufacture;
  - (e) quality control and inspection;
  - (f) updating, modification, and reissuing of drawings.
2. *Company standards* Many design offices use their own standard methods which arise from satisfactory past experience of a particular product or process. Also, particular styles may be retained for easy identification; e.g., certain prestige cars can be recognized easily since some individual details, in principle, are common to all models.
3. *Standards for dimensioning* Interchangeability and quality are controlled by the application of practical limits, fits and geometrical tolerances.
4. *Material standards* Physical and chemical properties and non-destructive testing methods must be borne in mind. Note must also be taken of preferred sizes, stock sizes, and availability of rod, bar, tube, plate, sheet, nuts, bolts, rivets, etc., and other bought-out items.
5. *Draughting standards and codes of practice* Drawings must conform to accepted standards, but components are sometimes required which in addition must conform to certain local requirements or specific regulations, for example relating to safety when operating in certain environments or conditions. Assemblies may be required to be flameproof, gastight, waterproof, or resistant to corrosive attack, and detailed specifications from the user may be applicable.

6. *Standard parts* are sometimes manufactured in quantity by a company, and are used in several different assemblies. The use of standard parts reduces an unnecessary variety of materials and basically similar components.
7. *Standards for costs* The designer is often required to compare costs where different methods of manufacture are available. A component could possibly be made by forging, by casting, or by fabricating and welding, and a decision as to which method to use must be made. The designer must obviously be well aware of the manufacturing facilities and capacity offered by his own company and of the costs involved when different techniques of production are employed, and also have an idea of the likely costs when work is sub-contracted to specialist manufacturers, since this alternative often proves an economic proposition.
8. *Data sheets* Tables of sizes, performance graphs, and conversion charts are of considerable assistance to the designer.

Fig. 1.1 shows the main sources of work flowing into a typical industrial design office. The design office provides a service to each of these sources of supply, and the work involved can be classified as follows.

1. **Engineering** The engineering departments are engaged in:
  - (a) current production;
  - (b) development;
  - (c) research;
  - (d) manufacturing techniques, which may include a study of metallurgy, heat-treatment, strength of materials and manufacturing processes;
  - (e) advanced project planning;
  - (f) field testing of products.
2. **Sales** This department covers all aspects of marketing existing products and market research for future products. The drawing office may receive work in connection with: (a) general arrangement and outline drawings for prospective customers; (b) illustrations, charts and graphs for technical publications; (c) modifications to production units to suit customers' particular requirements; (d) application and installation diagrams; (e) feasibility investigations.
3. **Service/maintenance** The service or maintenance department provides a reliable, prompt and efficient after-sales service to the customer and ensures in-house designed and manufactured equipment such as tooling are kept in optimum condition. The design office receives work associated with (a) maintenance tools and equipment; (b) service kits for overhauls; (c) modifications to production parts resulting from field experience; (d) service manuals.

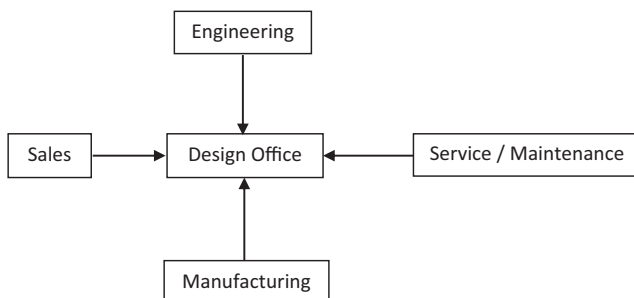
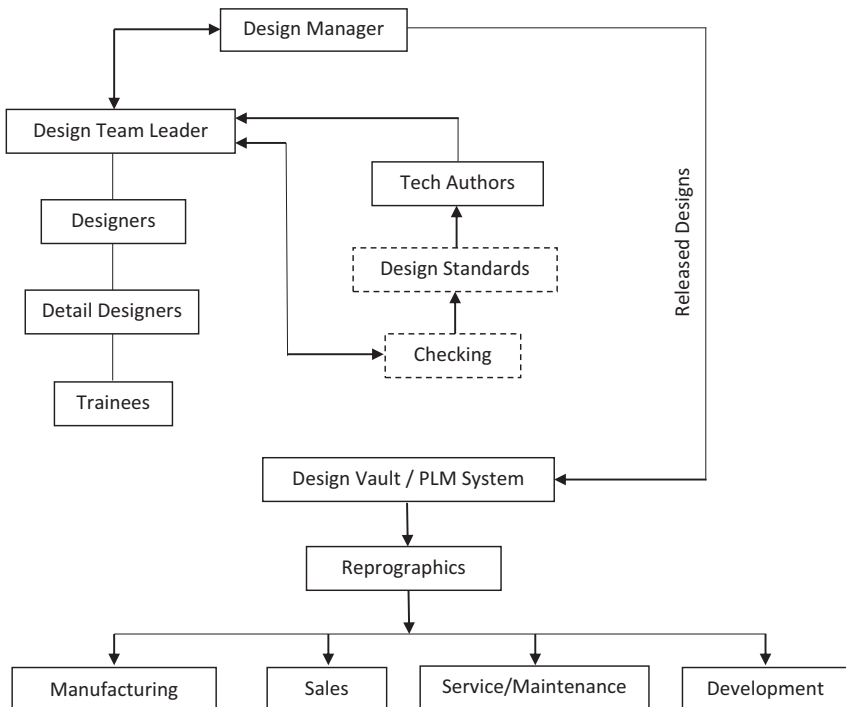


Fig. 1.1 Sources of information.

4. Manufacturing units Briefly, these cover all departments involved in producing the finished end-product. The drawing office must supply charts, drawings, schedules, etc. as follows:
- working drawings of all the company's products;
  - drawings of jigs and fixtures associated with manufacture;
  - plant-layout and maintenance drawings;
  - modification drawings required to aid production;
  - reissued drawings for updated equipment;
  - drawings resulting from value analysis and works' suggestions.

Fig. 1.2 shows the organization in a typical design office. The function of the design manager is to take overall control of the services provided by the office. The design manager receives work coming into the drawing office, which is examined and distributed to the appropriate design team leader. The team leader is responsible for a team of designers of various competences. When work is completed, the team leader then passes the drawings to the checking section if there is one, quite often, and wrongly, a dedicated checking team is thought of as an unnecessary expense and checking is carried out by other design team members. It is worth noting that the cost of correcting an error picked up by checking can be a tenth to a hundredth of the cost should it be found during manufacture. The Design Standards section scrutinizes the drawings to ensure that the appropriate Standards have been incorporated. Design Standards



**Fig. 1.2** Design Office Organization.

sections are again sometimes seen as unnecessary expense; however, the authors strongly disagree with this and recommend that a combined checking and design standards facility is maintained. All schedules, equipment lists, maintenance instructions and routine clerical work are normally performed by technical authors. Completed work for approval by the design manager is returned via the team leader.

Drawing are mainly produced by electronic methods but occasionally they may be produced manually, so suitable storage, retrieval and duplication arrangements are necessary. Systems in common use include:

- (a) computer storage preferably within a PLM system;
- (b) filing by hand into cabinets the original master drawings, in numerical order, for individual components or contracts;
- (c) microfilming and the production of microfiche.

The configuration, preservation and security of original documents whether hard copy or electronic is of paramount importance in industry. It is not normal practice to permit originals to leave the design office. The reprographic staff will distribute copies which are relatively inexpensive for further planning, production and other uses. The design vault or PLM system will maintain the design records for the life of the product and beyond where legislation requires. A large amount of design office work comes from continuous product development and modification, so easy access to past designs and rapid information retrieval is essential.

## Engineering drawing practices

The comments so far refer to design offices in general and typical organizational arrangements which are likely to be found within the engineering industry. Good communication by the use of drawings of quality relies on ensuring that they conform to established Standards.

BS 5070, Parts 1, 3, and 4 dealing with engineering diagram drawing practice, is a companion Standard to BS 8888 and caters for the same industries; it provides recommendations on a wide variety of engineering diagrams. Commonly, as a diagram can be called a 'drawing' and a drawing can be called a 'diagram', it is useful to summarize the difference in the scopes of these Standards. BS 8888 covers what are commonly accepted to be drawings that define shape, size and form. BS 5070 Parts 1, 3, and 4 covers diagrams that are normally associated with flow of some sort, and which relate components (usually indicated by symbols) functionally one to another by the use of lines, but do not depict their shape, size or form; neither may they in general indicate actual connections or locations.

Therefore, any drawing or diagram, whether produced on computer aided draughting equipment or manually, must conform to established Standards and will then be of a satisfactory quality for commercial understanding, use and transmission by electronic and microfilming techniques. All of the examples which follow conform to the appropriate Standards.

## Drawing practice and the computer (CAD: computer aided draughting and design)

The computer has made a far bigger impact on drawing office practices than just being able to mimic the traditional manual drawing board technique. However, it depends on design office requirements and if only single, small, two dimensional drawings and sketches are occasionally required and storage of originals is not an issue, then a manual drawing system may still be appropriate. CAD can however perform a much more effective role in the design process and many examples of its ability follow – but it will not do the work on its own. The intellectual input by the designer needs to follow the same standards as applied in the manual method and this fact is often not understood by organisations hoping to purchase CAD and obtain immediate answers to design enquiries. The designer needs the same technical appreciation as before plus additional computing skills to use the varied software programs which can be purchased.

To introduce CAD, an organization must set out clear objectives which are appropriate to their present and future requirements and Fig. 1.3 includes aspects of policy which could appear in such plans. The following need consideration:

- (a) CAD management roles;
- (b) creation, training and maintenance of capable CAD operators;
- (c) CAD awareness of design project team members in addition to their leaders;
- (d) the flow of work through the system and the selecting of suitable types of project;
- (e) associated documentation;
- (f) possible changes to production methods;
- (g) needs involving the customer and sub-contractor;
- (h) system needs relating to planning, security and upgrading;
- (i) CAD library and database (storage of drawings, symbols, etc.) and archive procedures;
- (j) configuration management.

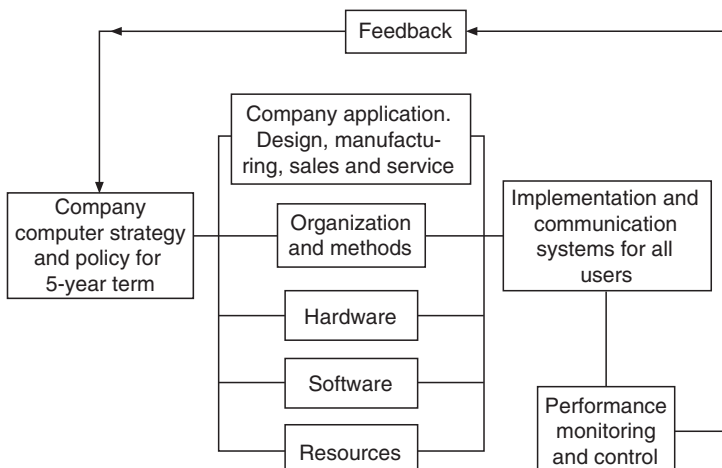


Fig. 1.3 General computer policy relationships.

When introducing or replacing a CAD system it is very important to take time to consider points (f) to (i) as these can have a major impact on through life costs. If you ask yourself the question 'In 5, 10, or 15 + years' time, will I still need to maintain the electronic product information?' and the answer is 'yes' or 'possibly' then the following needs careful consideration.

The need to consider possible downstream applications such as Computer aided Machining (CAM), Inspection (CAI), and Analysis, i.e. finite element analysis (FEA), compatibility with existing systems (or the requirement to replace them) being very important.

Compatibility with potential customer and sub-contractor systems should also be investigated because if this is a controlling requirement then selection of a suitable system could be limited.

Longevity of the manufactured products will also play a significant role in system selection. In many areas of industry regulatory or contract requirements demand retention of design records for a period of time after the product is withdrawn from service. This period of time, when added to the length of service, could be considerable, i.e. in excess of 25 years. As a result, costs associated with hardware and software upgrades and system maintenance need to be considered. In some cases, the costs associated with upgrades can be offset against new products, but nevertheless, ongoing maintenance of legacy databases can be costly. It is interesting to note that this was a problem that was often not foreseen in the early days of CAD. The rush by industry to move from the drawing board to CAD has, in some cases, led to companies changing CAD systems and struggling to maintain legacy drawings without costly redraws. Even today, with some very good CAD file translators on the market, 100% data transfer can't always be guaranteed without some remedial work.

A possible solution for consideration could be maintaining the drawings of a stable product on microfilm or possibly an enduring electronic format such as Adobe Acrobat files (.PDF). Some companies are already future proofing their design information by retaining drawings and models in their native CAD format and also in .PDF format and on microfilm.

Configuration control is also equally important to CAD systems as it is to manual systems and extra care needs to be taken to ensure unauthorized access to master files. Where costs allow using an electronic PLM (Product lifecycle Management) system to manage products through all phases of design, manufacture to disposal is highly recommended.

Many similar aspects will be appropriate in particular applications but good intentions are not sufficient. It is necessary to quantify objectives and provide dates, deadlines, numbers, individual responsibilities and budgets which are achievable if people are to be stretched and given incentive after full consultation. Lines of communication will need to be established to the directors of an organization and so that they can be kept aware of the costs and performance of the CAD/PLM system. A possible approach here could be for a director, say IT director, ultimately accountable for the system, assisted by a Systems Manager and an Applications Manager.

The accountable director will have the task of setting and implementing objectives and needs to be in a position to define binding policy and direct financial resources.

They will monitor progress. A Systems Manager has the role of managing the computer hardware, the software and the associated data. Company records and designs are its most valuable asset. All aspects of security are the responsibility of the Systems Manager. Security details are dealt with in the next chapter. The Applications Manager is responsible for day-to-day operations on the CAD system and the steady flow of work through the equipment. They will probably organize training for operators in the necessary computer skills. Both of these managers need to liaise with the design project leaders to provide and maintain a design facility which is capable of increasing productivity to a considerable degree.

Fig. 1.4 shows the probable position of the accountable director in the management structure. Their department can be the provider of all computer services to other computer users within the company, if this is the case then it is usual to have another manager responsible for the general office applications such as email, word processing and accounting packages.

Why Introduce BS 8888 and Withdraw BS 308?

For 73 years, BS 308 was a highly regarded drawing office practice document. Why the change and what was behind the decision to withdraw BS 308 and replace it with BS 8888?

## A drawing standard

From time immemorial, drawings have been the medium used to convey ideas and intentions. Hence the adage that 'a picture is worth a thousand words'. No need for language; the picture tells it all. In recent years there has, unfortunately, another opinion has developed since CAD appeared on the scene, that there is no need for a designer now as the computer does it all. The truth of the matter is that the computer

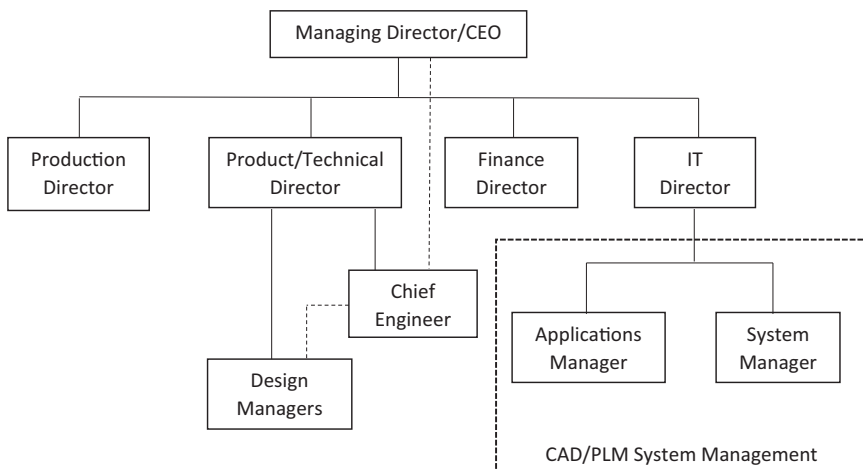


Fig. 1.4 Organization management structure.

is able to extend the range of work undertaken by the designer and; the quality of the product produced from a drawing is solely down to the competence of the designer. The evolution of the Industrial Revolution required the 'pictures' to be more detailed. In the pre-mass-production era, manufacture was based on 'matched fits', with the assistance of verbal communication. The advent of mass production however, demanded more specific and precise specifications.

A national form of draughting presentation was needed to promote a common understanding of the objectives and in September 1927, BS 308 came to fruition, as the recognized National Code of Practice for Engineering Drawing.

The initial issue was A5-size and contained only 14 clauses. Dimensioning was covered in four paragraphs and tolerancing in only one. The recommendations were based on just two example drawings. The recommended projection was first angle.

## Revisions

The life span of BS 308 was 73 years and five revisions were made. The first in December 1943, followed by others in 1953, 1964, 1972, and 1985. The 1972 revision was a major one, with the introduction of three separate parts replacing the single document:

The fifth (1985) revision replaced the Imperial standard with a Metric edition.

BS 308 was finally withdrawn and replaced by BS 8888 in 2000. The revisions were necessary to keep abreast of technological innovations.

As manufactured products became more sophisticated and complex, the progress and development of manufacturing and verification techniques accelerated. Advances in the electronics industry ensured more applications in manufacturing with a very high degree of sophistication. Much progress was also made since that single paragraph in the original 1927 version relating to tolerancing, together with the four paragraphs and the two examples covering dimensioning. Geometrical tolerancing was not referred to at all in early versions. The subject gained prominence during the 1960s, especially when it was realized that a symbolic characterization would assist in the understanding of the subject by users and replace the use of lengthy notes relating to geometric controls.

This activity was addressed by the major revision in 1972 with the publication of Part 3, devoted entirely to the dimensioning of geometric tolerancing.

## The replacement of BS 308

Formerly, the Chief Designer and the design office set, and were responsible for, company manufacturing Standards and procedures, for other disciples to follow. This practice gradually eroded away because of the advancement of progressive and sophisticated techniques in the manufacturing and verification fields.

Increasing commercial pressure for Design for Manufacture and Design for Inspection, created the demand for equal status. During the period separate Standards were gradually developed for design, manufacture and measurement. Each discipline utilized similar terms but often with slightly different interpretations despite their apparent commonality.

An urgent need to harmonize the meaning of these terms was recognized by ISO. An international meeting in 1989 formed a Joint Harmonization Group.

The Danish Standards Association funded a project to bring all design, measurement and metrology Standards together using definitions common to all, but with appendices for each discipline.

A full ISO committee (ISO/TC 213) was formed, with the Danish being responsible for the secretariat. The task allocated to this very vibrant committee progressed considerably, with many new international Standards being published. Today, British Standards Institute hold the secretariat for this very busy committee.

A major happening that would affect the future of BS 308 was the UK's agreement in 1993 with the European Standards Authority (CEN), whereby BSI would withdraw Standards relating to technical drawing in favor of the implemented ISO Standards covering the same subject. Initially, BSI systematically withdrew various clauses of BS 308 as the relevant ISO Standards were introduced.

PD 308 was introduced in June 1996 as a guidance document to assist the transition from BS 308 to the implementation of ISO drawing Standards. In 1999, as was the case in 1927, major decisions were deemed necessary, and the following were made:

- to transfer the United Kingdom totally to the ISO Standards base;
- to prepare an applications Standard to serve as both a specification for specifying and graphically representing products, and as a route map to the ISO Standards;
- to withdraw BS 308.

From this positive commitment, BS 8888 was created and published on 15 August 2000.

The complete comprehensive title of BS 8888 is:

## **BS 8888. Technical product documentation and specification**

### ***Basic differences***

The fundamental differences between BS 308 and BS 8888 are:

- The title of BS 8888 Technical product documentation (TPD) Specification for defining, specifying and graphically representing products.
- Confirmation of the conventional use of the comma as the decimal marker.
- BS 308 was a Code of Practice, a guidance document. BS 8888 is essentially an applications specification, providing a route map to over 160 ISO Standards. The operative word is 'specification'. BS 8888 carried forward and contains a significant number of valuable clauses contained in BS 308, which, at present, is not in any ISO documentation.

- BS 8888 is capable of accommodating significant technical changes known to be in development, plus the facility to accommodate future additions and changes.
- With over 150 related ISO Standards, BS 8888 has a much broader field of application than its predecessor and its 30 related ISO Standards.
- BS 8888 provides common understanding, and acceptance between the designer and the metrologist of 'uncertainty'. These are caused by differences between the Design Intent Measurand (Characteristics Specification) and the Measured Value (Characteristics Evaluation) of the actual manufactured part.
- BS 8888 is a uniform source of reference and will be regularly updated to keep abreast of developments as new international Standards are finalized and implemented.
- BS 8888 will capture any fundamental changes and will reflect moves toward an integrated system for definition, manufacture and verification.
- BS 8888 links some dimensional Standards to the appropriate stage of the design process and lays the foundations for future development.

BS 8888 has been revised every two years; however, this period may be extended to three or five years in the future. BS 8888 is available as a hard copy, and interactive CD with all referenced Standards and in the future as a Web based facility.

# Product development and computer aided design

## 2

Work undertaken by a drawing office will vary considerably with different branches of industry. Generally, work of a 'design and make' nature will follow a plan which sets out stages in development from the time a potential customer makes an enquiry until the completed product is delivered. The function of the product will dictate many of the associated activities.

A vehicle manufacturer will not design and make all of the parts used but subcontract components from specialists. The engine incorporates electrical and mechanical components and these need to conform to agreed upon specifications. They must also be designed for installation in specified areas and be suitable for operation in well-defined conditions. Component manufacturers strive to improve quality and performance in conjunction with the end user.

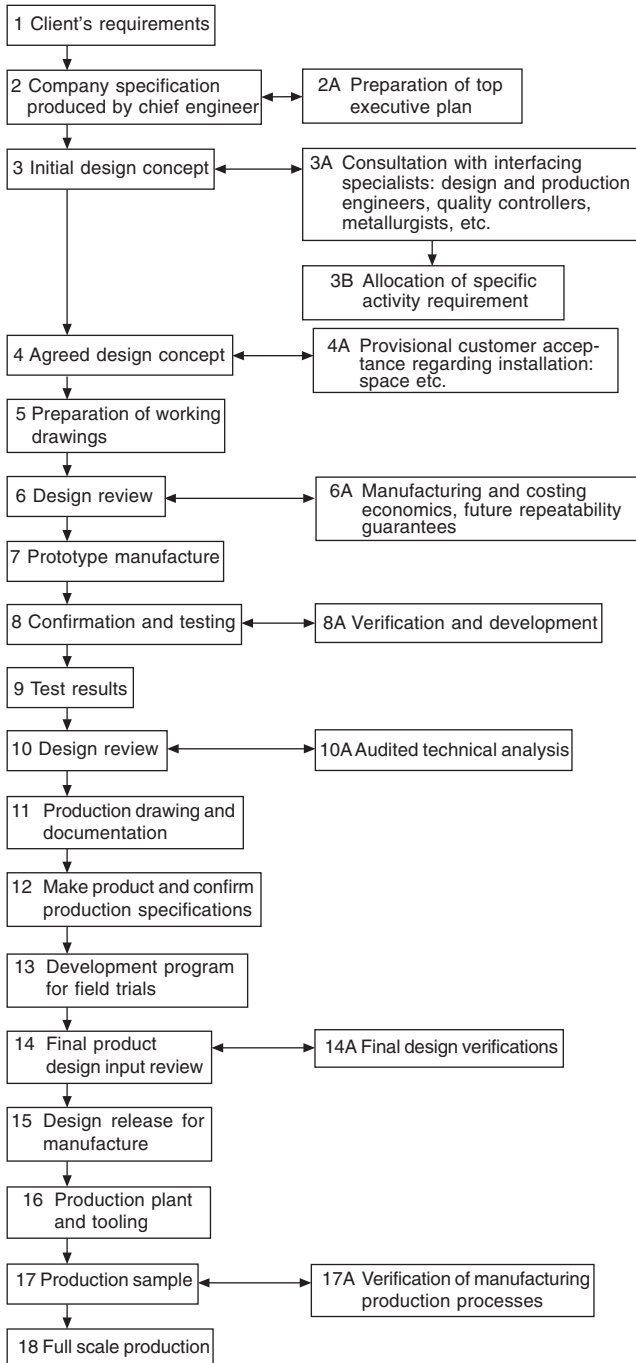
The stages in design and development for components in this category are shown typically, step-by-step in [Fig. 2.1](#).

**Step 1** A customer requiring a certain product is often not completely familiar with specific details and needs the experience and advice from a specialist producer to clarify initial ideas. When a range of viable alternatives is presented, opinions can be focused and firm decisions made.

**Step 2** The Chief Engineer or Design Authority in a company has the responsibility of producing the company specifications for a product including all applicable legislations, which the product will need to comply with, and the levels of configuration control required through the product life cycle. They will no doubt seek advice where aspects of the total design are outside his range of experience, and where design is involved on the fringes of technology. However, a top executive plan needs to be carefully prepared because at the outset the company must know whether or not it wishes to entertain, or get involved with, design proposals to satisfy the customer. For example, while rewards may be great, the firm may not be able to cope with the scale of financial and labor demands and delivery requirements in view of current work. They simply may not wish to take the risk and, in view of available production capacity, the firm may prefer not to tender for a possible order.

**Step 3** Drawings at this stage should be regarded only as provisional. The exercise is needed as an aid to think around the problem, with contributions being made by specialists within the firm to ensure feasibility.

CAD (computer aided design) has many virtues at this stage of primary design. All information, defined in mathematical terms, can be stored in the system and manipulated on the display. After the basic geometry is established, design variations can be kept, and in redrawing alternatives, sections of the previous proposals which were found to be acceptable can be used repeatedly. At any point in development, the designer can take a printout, so that suggestions and comments can be made by other technical staff. Consideration of the level of configuration control to be applied at this



**Fig. 2.1** Steps in design and development.

stage is important. In lots of cases the decisions as to why and why not a decision was taken (optioneering) needs to be formally recorded in some format.

It is essential that the company should appreciate the extent of their commitment if a firm order is accepted at a later date. This commitment includes not only the technical ability to complete the design and manufacture of a satisfactory product but also the financial issues relating to its introduction on the factory production line.

**Step 4** With the completion of preliminary design work an agreed design concept will be established, but it is necessary to obtain customer approval before work continues. If our product is to be used in conjunction with others in a large assembly, then, for example, expected overall dimensions and operational parameters need to be confirmed with the customer before money is spent on further development.

**Step 5** If all is well, working drawings will be prepared. These are not production drawings – at this stage, we as a company have only ensured that our proposals are in line with the requirements and that hopefully we shall be able to deliver. The object now is to prepare working drawings to formulate construction methods.

**Step 6** A design review is necessary to check the feasibility of manufacturing to ensure that all aspects of design requirements have been incorporated in an economic manner and to guarantee future supplies.

**Step 7** A prototype or a small batch may now be manufactured. The ultimate production methods of manufacture will not be employed here. For example, components which may be moulded could be machined from solid to eliminate casting costs.

**Step 8** Prototypes are used for testing to make certain that operational requirements of the specification can be achieved. As a result design changes may be necessary. Product tests cover all areas where the component will be expected to function without failure, and these could include use in extremes of temperature and humidity, and also when the component is subjected to shock, vibration and fatigue.

**Step 9** Proven test results are vital to confirm the validity of these tests.

**Step 10** A design review and analysis ensure that progress at this point will be acceptable in every technical aspect to each responsible member of the team.

**Step 11** Production drawing can commence now when the performance targets from the prototype have been confirmed. Drawings of the prototype will be reviewed and modifications made to use full-scale production processes during manufacture. For plant to be used efficiently, plans need to be prepared for loading and progressing work through the factory. The necessary documentation now commences.

**Step 12** Manufacture of the final product following production of the prototype has involved modifications and different manufacturing processes. It is therefore prudent to check that the specifications can still be kept.

**Step 13** Following trials where the equipment is used in its operational environment and its performance exhaustively checked and recorded, the design details can then be prepared for final review.

**Step 14** A final review will be necessary to establish that the outputs from steps 11 to 13 fully meet requirements prior to releasing the design for full-scale production.

**Step 15** Production involves not only the use of machines, but many jigs, fixtures, tools, gauges and inspection procedures need to be planned, and auxiliary equipment designed to move materials on and off production lines.

**Step 16** Inevitably teething troubles occur and samples are taken to verify that all plant and equipment operates as planned. Economic production requires that down time is eliminated before full-scale production commences.

It should be noted that the above steps can be tailored to suit the product being designed, for example, simple basic tooling may not require all the steps and it is feasible that steps 5 to 10 could be omitted.

## **Computer aided draughting and design**

CAD is much more than drawing lines and geometry by electronic means. Similarly by the purchase of a CAD system, a design does not emerge at the push of a button. The engineering designer is very much responsible for decisions taken at all technical stages between conception and production. The computer is an aid and performs as it is directed with rapidity and accuracy. The following notes are included to indicate areas of useful activity to assist the designer.

Today it is all too common at the design conception stage for designers to go straight into modeling mode and before they know it, they have slipped into detail design mode and include far too much information in the concept design. Designers are encouraged to sketch and/or build simple models (Lego, plasticine, card) at the early stages, this is not a backward step and rewards can be gained from unshackling the designer from CAD at the start of a project.

The preparation of two- and three-dimensional drawings and models and the projection of associated views is the 'bread and butter' work in the design office. Service manuals use exploded views so that people with no technical training can follow assembly sequences. Children stick together model kits with guidance using pictorial diagrams.

CAD programs are available where a three-dimensional model can be produced automatically given two-dimensional views. From the dimensions of the component, the computer will calculate surface areas, volumes, weights for different materials, centers of gravity, moments of inertia, and radii of gyration; it can also use the applicable values for stress and other calculations, which are a necessary part of design. Computer models permit a study of special relationships and applications, which are given in the chapter which follows. Models can be manipulated into pleasing forms for artistic approval or for the basis for Additive Manufacturing or Rapid Machining before production work follows. Previous techniques included modeling with plasticine and plaster, and applications ranged from ornaments to boat hulls and car bodies. CAD has revolutionized modeling capabilities.

Sales departments utilize 3D illustrations in brochures and literature for promotional applications. Desktop publishing from within the company can very simply use illustrations generated as part of the manufacturing process. The scanning of photographs into a CAD system is also an asset especially as photographic work can be retouched, manipulated and animated. Multimedia applications with video and slide presentations form a large part of selling and advertising.

Structural design requires a thorough knowledge of engineering material properties. Calculations of stress, strain and deflection are essential to determine proportions and dimensions in structural applications. Computers now have the ability to perform

millions of calculations per second and with the availability of powerful desktop models, finite element analysis has developed as a principal method. One advantage of finite element analysis is that design engineers can produce better designs and eliminate dubious options during the conceptual design phase. CAD systems permit the rapid generation of models of proposed designs as wire frames. The component can be defined as a collection of small loaded elements. The computer memory stores details of all the geometric data to define each part of the frame. Numerical analysis will then verify whether or not the suggested design will be capable of supporting the expected loads. Formerly, stress calculations were time consuming and in the early days of computing, although the calculation time was considerably shorter, computer time was relatively expensive. This is not the case now and for this type of design work CAD is an essential tool in the drawing office. However, it is advisable to ensure the designer using these tools has a good understanding of traditional methods of calculation in order to have confidence in the electronic output.

CAD is very suitable for repetitive and fast documentation where a product is one in a range of sizes. Assume that we manufacture a range of motor driven pumps operating at different pressures. Many parts will be used in different combinations in the range and the computer database documentation is programmed accordingly. Company standard designs will be offered when enquiries are received. A computerized tender can be sent with the appropriate specification and technical details. On receipt of an order, all of the documentation relating to manufacture, testing, dispatch, and invoicing will be available. An obvious advantage is the speed of response to the customer's enquiry.

CAD should be linked to CAM (Computer Aided Manufacture) whenever possible. Documentation will include parts lists, materials details of parts to be manufactured or bought out, stock levels, computerized instructions for numerical controlled machine tools, and instructions for automated assemblies, welding equipment, etc. Printed circuit boards can be designed on CAD and manufactured by CAM.

Production tooling requires the design of many jigs and fixtures. A jig is a device which holds the component or is held on to the component, locating the component securely and accurately. Its function is to guide the cutting tool into the component or for marking off or positioning. A fixture is similar to a jig but it does not guide the tool. Generally a fixture will be of heavier construction and clamped to the machine tool table where the operation will be performed. Jigs are used frequently in drilling and boring operations. Fixtures are a necessary part of tooling for milling, shaping, grinding, planning and broaching operations. The use of jigs and fixtures enables production to proceed with accuracy, and hence interchangeability due to the maintenance of tolerances (see Chapter 21) and especially by the use of unskilled or semiskilled labor and robotics.

The traditional method of jig and tool draughting was to draw the component in red on the drawing board. The jig or fixture would then be designed around the component. This process ensures that the part is located and clamped correctly and can be loaded and unloaded freely, and that the machining operation can be performed without hindrance.

With a CAD system, the component drawing can be shown in color on one of the 'layers' (see Chapter 5) and design work undertaken on the other layers. If designing

uses three-dimensional CAD systems, the tooling can be designed around the model of the product again using appropriate layering.

Machining operations need to be checked to ensure that tools and cutters do not foul any other equipment in the vicinity. The path taken by the tool into its cutting position should be the most direct and the shortest in time. The actual cutting operation will take a different time and the tool may traverse the component several times, cutting away more material on each occasion. Machining sequences can be simulated on the screen and when the optimum method has been obtained, the numerical program is prepared. All relevant data for the machining operation is converted into coded instructions for continuous production.

Programs are available for the economic use of metallic and non-metallic materials. Many engineering components are manufactured by flame, laser, wire or water jet, cutting intricate shapes from plate or sheet and these need to be positioned to minimize scrap. The cutting head is guided by computer using the  $X$  and  $Y$  coordinates at each point along the curve. Other applications use a variety of cutters and saws to shape materials singly or heaped into a pile, such as foams in upholstery or dress fabrics.

The tool designer, for example, will use many standardized components in tooling and designing associated handling equipment for production. If a range of parts is similar, it is common practice to produce a single drawing with dimensions in a table of the separate features. A typical example is given in Fig. 7.2 and is the normal manual draughting procedure. CAD can, however, use a parametric technique where the component drawing is dimensioned by algebraic expressions understood by the computer. Each separate size of component will be given its own part number. When a particular part is required and called up, the computer calculates sizes and draws the part to the correct scale for the designer to position where required on the assembly drawing. This is a very useful facility and only available through the introduction of CAD.

CAD always produces drawings finished to the same high standard, and of a uniform quality and style.

It will be seen from the above notes that CAD fits in with many of the separate procedures necessary for design and production, but it is vital that, before its introduction, software must be available with proven ability. Likewise, staff must receive training to extract the maximum advantages and benefits.

## **Technical product documentation**

Individual companies generally develop their own systems largely depending on the type of work involved and the size of the undertaking, e.g. original designs, drawing revisions, modifications, repairs, new contracts, enquiries and proposals.

These notes provide guidelines for new business routines where both manual and computer-based systems are used. They refer to internal communication within companies and between other organizations.

There are five short Standards dealing with the handling of computer-based technical information during the design process.

Part 1: BS EN ISO 11442-1. Security requirements.

This document details advice and precautions regarding the system installation, power supply, ventilation and cooling, magnetism and electrostatic environment, and also computer access.

Notes regarding service and maintenance, stand-by equipment and back-up copies are given. Useful comments relate to document authorization and copyright.

Part 2: BS EN ISO 11442-2. Original documentation.

Definitions are provided for various types of document used by industry in the Drawing Office.

Part 3: BS EN ISO 11442-3. Phases in the product design process.

Distribution of documents during each phase is detailed.

Part 4: BS EN ISO 11442-4. Document management and retrieval systems.

This section deals with activities in the design process and the handling of associated documents, e.g., identification and classification of administrative and technical documents. Provides helpful advice in the management of documentation in parallel with the phases of product development. Assistance also given for drawing revisions, document handling, classification and retrieval of data.

Ready-made 'Turnkey' data-processing systems are available and can be adapted by specialist suppliers.

Part 5: BS EN ISO 11442-5. Documentation in the conceptual design stage of the development phase.

Part 5 deals with documentation in the preparation of a design specification, design proposals and solutions.

Problems can arise from power cuts of short and extended time periods, from spikes, or from fluctuations of power due to other electrical equipment being switched on. Stormy weather can cause surges and static build-ups. A reliable power source with a stable supply is essential. Consideration should be given to the provision of a backup supply, if in doubt. Service and maintenance arrangements may require the issue of external contracts, as computer down time resulting in lost production can prove expensive.

Computers generate heat, and wide variations in environmental temperatures should be avoided. Air conditioning in the complex may be necessary if cooling is required and clean air cannot otherwise be guaranteed. Part of the computer complex i.e. where the servers and back-ups are held, may need to be out of bounds except to authorized personnel to maintain an acceptable environment. Ensure that the CAD complex is kept locked and secure when not in use at night and weekends.

An organization must develop a routine for storing data on which company fortunes may depend. In the event of power failure, work in progress may be lost. It could also be lost due to operator error or computer malfunction, fire, flood, vandalism, etc. Backup routines must cover personal responsibility aspects, together with frequency of copying, storage medium and designated places of safety. Backup copies should not be stored in the same buildings as the originals.

Programs used for operating and applying CAD systems need to be checked at regular intervals to ensure that intended methods are being kept in practice. Computer aided designs and production information could easily be copied and some countries do not have legislation prohibiting unauthorized use. Documents should therefore include a clause relating to copyright where design information is transmitted; it is recommended that the clause should appear before the text and again at the end.

Many grades of staff are involved in the design process; senior designers, detailers, checkers and technical clerks all make a positive contribution. Each member's duties must be carefully defined with rules applied, and an authority given, so that each can only operate within his or her agreed sphere of activity. By means of passwords it is possible to access design information at appropriate levels. Revision procedures will ensure that modifications are only made at the correct point by authorized designated staff. Quality assurance systems require strict application of these methods.

## Access into the computer network

Every CAD installation requires access responsibilities to be defined for the operating staff and the following example relates to an educational establishment.

A typical College of Technology may consist of three separate departments, each requiring to use a common computer facility where a central processing unit is installed. Each department is serviced using a tree and branch system leading to the desks of staff holding different levels of responsibility, and to student outlets in classrooms, drawing offices and laboratories. All members of staff and students need to gain access to the computer freely, and in their own time, and be able to store their work safely.

A Head of Department, however, may need to gain access to the students' work to monitor progress.

All members of the college staff would wish to have a personal file and keep confidential records. A lecturer must be free to allocate space to students in several classes, so he or she will open subdirectories as necessary and possibly delete work at the completion of a course.

Fig. 2.2 shows a directory structure where access can only be made into the system provided the keyboard operator logs in a personal identity number. Each member of staff will be assigned two directories:

- (a) a top level directory (TLD);
- (b) a personal directory (PD).

The TLD is the attach point for the user into the system. The lecturer is free to open subdirectories for students' work and each student's file will be protected from the rest of the class. The Head of Department has access to a lecturer's TLD and through to a student's file.

The above system can be adapted for any graded organization where controlled access and protection for records is desirable.

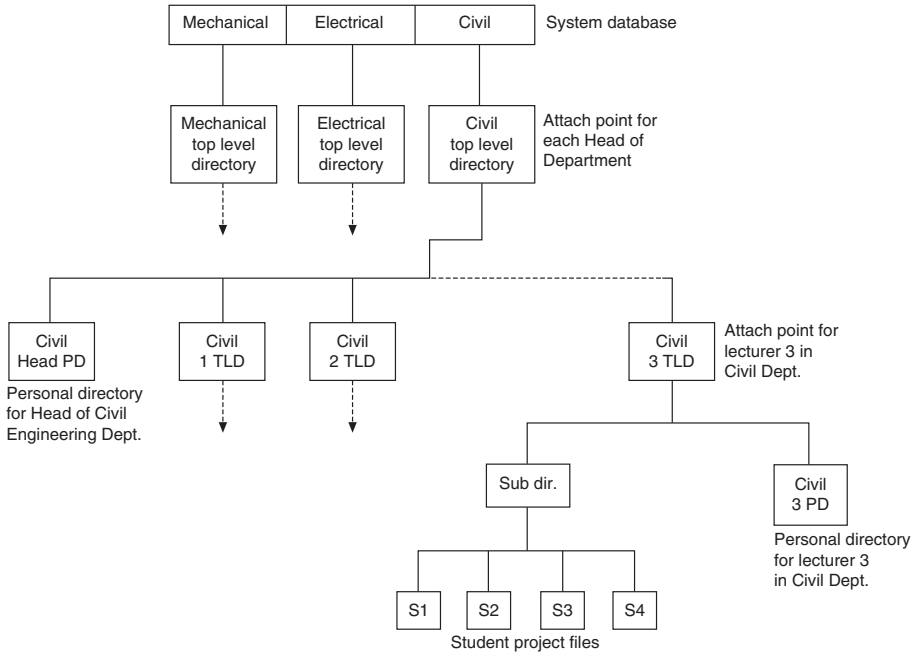


Fig. 2.2 Directory tree for controlled access to database.

## Quality assurance

BS EN ISO 9000 series relates to quality systems and is produced in several sections. The principles of quality assurance (QA) embrace all activities and functions concerned with the attainment of quality. *BSI Quality Management Handbook QMH 100* is essential for reading.

Having purchased quality CAD equipment, the products which the company propose to manufacture need to be designed and developed from conception following an agreed *quality assurance* working procedure practiced by all employees throughout the organization. QA systems are usually accredited and certified by a third party such as a professional institution or association.

An organization should be able to show that all drawings, documentation and necessary calculations relating to the design are vigorously checked and approved by management. The stage by stage development of the product will follow an agreed work plan with checks, inspections and correction procedures. Similar plans will cover the manufacturing stages from raw material checks to the tested product. Good communication between all of the participants is essential to ensure that the product meets its specification and the customer's exact requirements.

A company which can demonstrate superior technical skill and expertise has a considerable asset, which can be used to advantage in marketing. Proven excellence invariably increases pride and well-being in company employees.

# Design for manufacture to end of life

## 3

There has been much written about Design for Manufacture and Design for Assembly techniques, all aimed at reducing the cost of design and production. Today, the designer is probably familiar with the term *Design for X* where X is the specific area the design relates to. Examples of X could be:

- Manufacture
- Assembly
- Maintenance
- Environment
- Re-use
- Disposal
- Recycling
- Environment
- Life cycle.

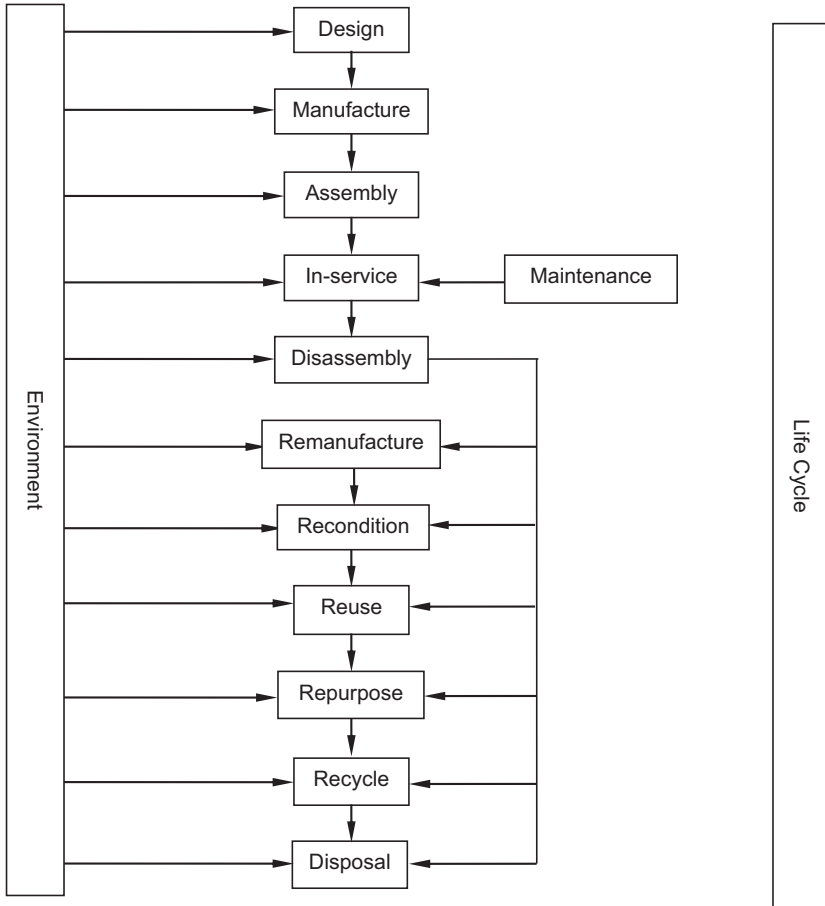
As can be seen, with the exception of life cycle, the ‘Design for’ initiatives relate to just one element of a product’s life cycle whereas designers should be considering designing for the whole product life cycle from manufacture to disposal (see Fig. 3.1).

Whilst design for the environment spans the product life cycle, it can be considered to apply separately to each element of the life cycle by minimizing the impact on the environment from the procedures, materials and waste streams produced by that element.

The British Standards Institution (BSI) recognized that whilst there are standards on design management (BS 7000 series) and product specification (BS 7373 parts 1 & 2) there was a deficiency in standardization covering the whole product life cycle.

The BS 8887 Design for manufacture, assembly, disassembly and end-of-life processing (MADE) series has been (and is being) developed to give the designer better insight into preparing design concept and specification documentation for use beyond the manufacturing stage. BS 8887-1 (first published in 2006) introduces the general concepts, processes and requirements for Design for Manufacture, Assembly, Disassembly and End of Life Processing (MADE). It is not intended to be a teaching aid for designers but does provide information for designers to make the most cost-effective use of their design output by specifying requirements for the preparation, content and structure of the design output across the product life cycle. It is highly recommended that designers familiarize themselves with this standard and use it in conjunction with BS 8888 – Technical Product Documentation and Specification, to ensure fully specified designs.

Parts of BS 8887 numbered 1 to 99 relate to general MADE standards; parts numbered 100 to Part 199 are related to manufacture and assembly; and parts numbered 200 to 299 are related to disassembly and end-of-life.



**Fig. 3.1** Design process for manufacture to end of life.

BS 8887-1 gives the designer a good insight into the philosophy of Design for MADE by setting out requirements and parameters for the:

- Design Process
- Design Brief
- Design Methodologies, including Best Practice Sequence of Events
- Orientation Phase
- Definition Phase
  - Outline Design
  - Feasibility Studies
  - Prototype Design
  - Prototype Evaluation and Feedback
- Realization Phase, Including:
  - Detail Design
  - Lifecycle Considerations

- Design for Assembly and Disassembly
- Risk Assessment
- Handover Phase
- Cost Considerations, including:
  - General Cost Considerations
  - Development Costs
  - Marketing Costs
  - Materials Costs
  - Manufacturing, Assembly, Disassembly, End-Of-Life Processing Costs
- Industrial Design
- Detail Design
- Requirements for Assembly
- Parts in the Assembly
- Ease of Assembly
- Ease of Disassembly
- Life Cycle Considerations
- Requirements for Verifications
- Documentation
  - Design Documentation
  - Manufacturing Documentation
  - End of Life Documentation.

To give the designer a more complete picture, BS 8887-1 contains informative annexes of established design techniques and processes. These annexes cover:

- Brainstorming;
- Quality Function Deployment;
- Value Engineering, Failure Mode and Effect Analysis;
- End of Life Consideration;
- Risk Assessment;
- Industrial Design;
- Life Cycle Considerations;
- Technical Product Realization Concept.

In 2017 BS ISO 8887-1 Technical Product Documentation – Design for Manufacturing, Assembling, Disassembling and End-of-Life Processing was published as an international standard by the ISO TC10 who are responsible for Technical Product Documentation. Based on BS 8887-1 it aims to identify the documentation requirements of end-of-life processes when a customer has finished with a product by considering the disassembly of the product and looking at Reworking, Recycling, Reusing and Disposal and introducing these into the design and development of products. It specifically relates to:

- Manufacturing of components
- Assembling of components into a product
- Disassembly of a product into components
- End-of-life processing of the components

This standard has eight clauses covering in more detail the following types of documents:

- Design aims
- Design documentation
- Design brief
- Design concept
- Iterative stages
- Design archives
- Manufacturing and assembling
- Disassembling and end-of-life processing.

In addition, there are two very informative annexes which the designer is encouraged to read, covering a) the number of components and ease of assembly and disassembly and b) life cycle considerations.

In 2009, to complement BS 8887-1, BSi published BS 8887-2 which specifies all the terms with definitions that apply to the Design for MADE process. Designers are recommended to review these terms as they could well be cited in any contract associated with the design of a product.

In 2012 BS 8887-3 was released which is a guide to choosing an appropriate end-of-life design strategy.

This standard discusses the environmental, business and marketing cases for MADE and makes a good point about including product packaging in the design thinking by reducing the amount of packaging and making it reusable. It also expands on the six processes for end-of-life components could follow as shown in [Fig. 3.1](#) (remanufacture, recondition, reuse, repurpose, recycle and disposal) giving requirements and the pros and cons for each process. In addition, it also considers extensively the design, production, use and verification implications for these end-of-life processes.

As noted earlier in this chapter, much has been written about the front end of this process, i.e. Design for Manufacture and Design for Assembly. With this in mind BSi have concentrated on the ‘back end’ of the process and in 2010 published BS 8887-220, which specifies the process of re-manufacture. Essentially, this Standard specifies the requirements for re-manufacture including the process required to produce ‘as-new’ products from ‘used’ products and covers:

- Collection of Technical Documents (relating to the original product);
- Collection of Core, which is a component or product retained throughout the re-manufacturing process;
- Initial Inspection (of the Core) against acceptance criteria;
- Disassembly;
- Detailed Inspection of Components;
- Remediation of Components (to ensure a component meets ‘as-new’ specification);
- Cosmetic Remediation of Components;
- Replacement (of non-conforming components);
- Reassembly;

- Testing, including validation of the re-manufacturing process and re-manufactured product and issuing of warranty;
- Identification and Marking.

Another ‘back end’ Standard, BS 8887-240, was published in 2011 and this specified the process of ‘Reconditioning’ which specifies requirements for the process of ‘Reconditioning’, i.e. returning a used product to a satisfactory working condition by rebuilding or repairing major components that are close to failure, even where there are no reported or apparent faults in those components. The reconditioning process can include parts or components to be used in subsequent assembly. It should be noted that BS 8887 part 240 is only applicable to manufactured products.

Although not directly associated with design, BS 8887 part 211 published late in 2011 covers ‘Remarketing of computing hardware’. This part is specific to the IT industry sector and specifies requirements for the categories within which used computer hardware is remarketed. It covers the hardware and where applicable the operating system software and firmware, but excludes application software or personal productivity tools. Its purpose is to give IT sector remarketers the vocabulary and procedures needed to accurately define their products. This is needed because the industry sells a variety of used products under a number of different grades and identifications. It defines the following:

- Re-manufactured
- Refurbished
- Repaired
- Unopened returns
- Upgraded.

This enables the user to understand the processes undertaken by the reseller and also the level of quality of the final product.

In 2012 BS 8887-211 Specification for reworking and remarketing of computing hardware was released. The purpose of this standard is to standardize the vocabulary and procedures needed to define remarketed products. It defines the following:

- Remanufactured
- Refurbished
- Repaired
- Unopened returns
- Upgraded

At first look this standard may not seem overly design centric but designers at the start of a project should take the time to study it as there may be chance that the processes described if followed could prove beneficial in the sustainability, environmental responsibility, commercial fields and add value to the product at end-of-life (even if the product is not computing hardware).

Over the coming years the BS 8887 family of Standards will encompass the entire Design for MADE cycle. Designers are encouraged to review the BSI website ([www.bsi-global.com](http://www.bsi-global.com)) for developments and new publications in the BS 8887 family of Standards.

# Intellectual property and engineering design

# 4

Intellectual property (IP) and engineering design are inextricably linked as both rely on the intellectual skills and creativity of individuals.

The aim of this chapter is to provide an overview of the connection between the main types of IP and engineering design together with its associated documentation.

The field of IP is a 'gray area' to a vast number of engineering designers who often loosely and inadequately refer to this as the patent side of the business. IP is a great deal more than 'just patents'. It is about legally enforceable trade exclusivity in favor of the owners of the property.

The four main types of IP are for.

- patentable inventions;
- designs of or as applied to articles;
- copyright works;
- trademarks for goods or services.

IP can bear on all facets of engineering design. Like any other form of owned property, it can be bought or sold. The legally attached rights of trade exclusivity can be licensed, i.e. access can be hired to others by the owners.

Therefore it follows that a general working knowledge of these facets of IP should be a 'must have' in every design engineer's toolbox to ensure that the fruits of their labor gain the full benefits that IP offers. Ignorance of this awareness could result in serious financial loss if it transpired that the rights of others were being infringed because of a present or future design project.

Lack of awareness of what is already officially published on the registers of proprietary products or processes (i.e. the patent register), and of designs and trademarks, could be an unexpected pitfall into which an engineering designer might stray.

Almost all countries have intellectual property offices. In the United Kingdom, the Intellectual Property Office (IPO) (formerly called 'The Patent Office') is the government office which handles all aspects of IP. It publishes guidance booklets and accepts applications for registration.

## Patents

Certificates of ownership of legally qualifying products and processes, i.e. patent certificates, will be issued by patent offices on application by their prospective owners, so long as the patent offices regard the products or processes described in the technical description as satisfying the legal requirements for registration.

The technical description of the product or process comes from the mind of an individual who is given the legal name ‘inventor’.

To be eligible for a patent, the claimed product or process features must be.

- globally original, i.e. novel;
- inventive;
- suitable for industrial application;
- not restricted from patenting, such as a mathematical formula on its own or software on its own.

The patent office is not concerned with whether the production of the product or process would infringe another’s rights. The issue of commercialization is a legally separate matter.

The applicant must also complete formalities on time, including paying official fees.

Once issued, the claimed product or process is entered on the patents register, which is open to the public. Once on the register, the owner can sue in cases of the rights being infringed. The patent is not a permission to use the invention, rather to prevent others from gaining trade value without permission.

To maintain novelty, the new product or process must be kept totally secret (unless under the cover of confidentiality agreements) until the patent application is made and given an official filing date.

The term of a patent is generally 20 years subject to the owner paying occasional renewal fees to the patent office.

A correctly formed patent application is a technically complex document to compile, more often than not requiring the expert assistance from a patent attorney. The patent attorney might also arrange for prior art searches to be carried out to help establish the novelty and inventiveness.

If any new product or process is to be marketed by a company, a patent attorney can run separately a freedom-to-operate search with the aim of finding any blocking patents.

Patents covering the UK can be gained by application to the IPO, or to the European Patent Office and designating the UK as a state for the anticipated European Patent.

International Patent Applications designating over 140 states can be made under the Patent Cooperation Treaty, with the IPO acting as a Receiving Office for the World Intellectual Property Organization. The International Patent Application is thereafter passed to the IPO or EPO for examination on inventiveness.

## Designs

Design rights relate to the physical or aesthetic appearance of articles as a whole or in part, or to designs that are applied to articles. These rights are not concerned with the technical performance of the designed article, rather ‘the look’.

The criteria and eligibility for design rights are complex. There are two kinds of rights – registered designs and unregistered designs.

## ***Registered design rights***

Almost all countries have registered design offices which are part of their intellectual property offices. Rights to registered designs are absolute because there can be infringement without any direct copying of an existing article embodying the design.

Registered designs covering the UK can be obtained by making an application to the IPO or to the EU's Office of Harmonization of the Internal Market for a Registered Community Design.

Certificates of ownership of qualifying designs, i.e. design certificates, will be issued by a design registry on application by their prospective owners so long as the design registry regards the designs as satisfying the legal requirements for registration. Each design comes from the mind of the designer, no matter whether that person is named on the application.

The qualifying design can apply to the appearance of an article as a whole or a part. It can relate to color, contours, lines, materials, shape or texture.

To be eligible for registration, the design must.

- be globally original, i.e. novel;
- have individual character;
- not be of a kind restricted from design registration.

The applicant must also complete formalities including paying official fees.

Once issued, the design is entered on the design register which is open to the public.

To maintain novelty, a new design must be kept totally secret (unless under the cover of confidentiality agreements) until the design application is made and given a filing date.

The term of a registered design is generally 25 years subject to the owner paying for occasional renewal fees to the design registry.

A design application is less complex to compile than a patent application but might require the assistance of a patent attorney.

If any new design is to be marketed by a company, a patent attorney can run separately a freedom-to-operate search with the aim of finding any blocking design registrations.

In the USA, registered designs are referred to as design patents.

## ***Unregistered design rights***

These are special rights, available in the EU, which remove owners' rights over the designs of three-dimensional objects from the prior cover and thus the unduly prolonged term of copyright works.

The unregistered right applies to designs of articles such as certain kinds of spare parts. There is a maximum duration of 15 years under UK law and three years in the EU under a European Commission Regulation.

To qualify, the designs must not be commonplace but are not necessarily novel to the world. There are qualifying criteria for the eligibility of potential owners.

Rights for semiconductor masks come under this in the UK.

The unregistered design right results from the mind of the designer and comes into automatic existence when the design document is created or when an article embodying the design is made.

The unregistered right is only a right against those who directly copy the design. Copying has to be proven for there to be infringement of the right.

## Copyright

This is an exclusive right for the owner of a qualifying, intellectually original work, giving control over its reproduction by copying, in accordance with what the law states.

It is an automatic right against copying which arises as soon as the work is formally written down or drawn on paper or recorded in a computer data store.

Qualifying works must be original and involve a minimum level of effort to be regarded as 'a work'. Works can be of different kinds — they can be literary (including computer programs), paintings, graphics, maps, photographs, sound recordings, video recordings, broadcasts or computer generated images. Typefaces can be original copyright works, as too can compilations by publishers of anthologies of individual copyright works.

Qualifying works are usually identified by the owner with the copyright roundel, the name of the owner, date of creation of the work and country of creation.

Data in databases can be subject to copyright if there has been an original intellectual input into what is in the database. This is not to be confused with the Database Right, a separate right in the UK relating to the extraction of data from a database.

No registration is possible for works of copyright (or designs under the unregistered design right). To prove ownership, the owner must ensure that a detailed record of the work (or design), its ownership and authorship, sufficient to stand as evidence in a court, is prepared when the work is created.

The terms of copyright vary depending on the nature of the work. For literary works in the EU, the duration of copyright is currently 70 years after the date of death of the author.

## Trademarks

A registered trademark is a sign that distinguishes the registered goods or services of one organization from that of another. It is a marketing tool and there is no author, just the owner.

A certificate of ownership will be issued by a trademark registry on application by the prospective owner, so long as the registry regards the sign as satisfying the legal requirements for registration.

Typically, the sign is formed of one or more words, in a plain or stylized font.

It can also be figurative in nature, optionally incorporating words. Exceptionally, a trademark sign can be a three-dimensional object, a sound, a musical jingle or a scent.

The trader must apply for registration of a specific mark for one or more specific classes of goods or services that are internationally classified.

A proposed trademark cannot be validly registered, if the mark.

- is already registered;
- is similar to a mark registered for the same class of goods;
- is descriptive of the goods or service; or
- is barred from registration (such as state insignia).

The mark has to be distinctive by law.

The applicant must also complete formalities including paying official fees.

Once issued the trademark is entered on the trademark register, which is open to the public.

There is no fixed term for a registered trademark as the registration can be renewed every 10 years so long as the mark, exactly as registered, is in use in the owner's trade.

Trademark attorneys can give advice and arrange for searches to ascertain whether a desired mark is available for registration.

Trademarks covering the UK can be issued by making an application of qualifying marks to the.

- IPO;
- EC's Office for Harmonization for the Internal Market for a Registered Community Trademark; or
- World Intellectual Property Organization for an international trademark under the Madrid Protocol.

Inclusion of a registered trademark on an engineered product is a particularly useful defense against counterfeiters as it is an offense to counterfeit a trademark.

## **Important points to remember**

1. Patentable inventions and registrable designs must be kept secret before applying for registration. Failure to do this will likely destroy the legally defined requirement for novelty and so any possibility of valid registration.
2. In law, the creators of works (authors, designers, inventors) are regarded as legally separate from the owners; even though they can coincide in individuals. In the USA, the first owners are the persons who are the authors, designers or inventors. In the UK, employers might be the first owners. The law sets out what the criteria are.
3. The authors strongly recommend that all potential creators of works of the mind, such as inventors, take advantage of the information published by the IPO in the initial stages of any of their work which they consider could embrace IP.
4. The above is not an exact statement of law on any aspect of the complicated field of IP. Proper research and advice must be taken by any reader who wishes to investigate any IP-related issue.

# CAD organization and applications

# 5

Computing developments have made a rapid and immense impact on industry and commerce and as the degree of complexity has also increased, so training facilities have expanded accordingly. As a source of information and communication, the Internet and to a lesser degree the Technical Press play a very important part. Journals from professional institutions offer impartial news, advice and guidance, opinions, and new product details. Manufacturers and the larger suppliers of CAD (computer aided design) equipment have set up centers around the country where exhibitions and demonstrations are organized. Higher education establishments, private organizations, and dealerships also give specialist courses for the benefit of students and users.

The mainstream engineering software programs have been written and developed in the United States and the United Kingdom. To perform complex tasks, additional programming may need to be seamlessly integrated so that they work in harmony as a unit.

There are literally hundreds of specialist applications available. Banks, building societies and airlines all have their own systems and, via the Internet, can freely communicate with each other. This fact has also given rise to another branch of industrial development, i.e. IT security.

Screen sizes have increased in size and reduced in cost and the availability of the flat screen has reduced the size of workspace required by users, however it is common these days for a designer to have two or three screens at their disposal.

The provision of multi-layers provides a very useful method of working on CAD. Imagine transparent sheets placed on top of each other, which may be shuffled and rearranged so that you can draw on the top. Each of the layers underneath the pile can be turned on or off; they may be given identification colors and selected parts of drawings moved from layer to layer if required. Assume that we want to draw plans for a house. Layer 1 could be used to draw a plan view of the building plot. Layout work is often easier if graph paper is used. On layer 2 we make our own construction grid, which is transparent graph paper with squares to any convenient scale of our choice. Using this grid under layer 3 we design a suitable ground floor layout. Copying the position of the outside walls from layer 3 and modifying as required could start layer 4 showing the first floor layout. When all of the required plans and elevations are constructed, they can be repositioned on a drawing arrangement. If necessary, the site layout can be reduced to a smaller scale. When completed, the construction grid may be deleted. Tracing facilities and the ability to print layers together or apart are valuable draughting assets.

The physical equipment components of a computer system are known as the *hardware*. The programs and data used on the computer are defined as the *software*.

Another advantage of CAD is its ability to store line systems and other entities, which are frequently used on drawings. For example, software containing symbols

to British, European and other International Standards is freely available for most engineering applications. The designer can also create libraries of regularly used parts.

For repetitive use on a drawing, a typical item may be retrieved and positioned in seconds, and also oriented at any angle to suit particular circumstances.

As a drawing aid, every CAD program must provide basic geometric features, permitting the operator to blend lines and arcs, etc. It is necessary in engineering drawing to be able to determine points of tangency between straight lines and curves and between curves of different radii.

Productivity is much improved by a program enabling you to easily draw polygons, ellipses, multiple parallel lines and multiple parallel curves. The speed of machine drawing is increased by the use of automatic fillets and chamfers. Layout work benefits when use is made of construction grids, and the computer's ability to 'snap' automatically to particular geometric points and features will speed the accurate positioning of line work. Copy, rotate and mirror facilities give assistance when drawing symmetrical parts. Automatic cross hatching within closed boundaries is useful in the construction of sectional views and when indicating adjacent parts and different materials. Many changes of hatch patterns are supplied with CAD programs. Filling areas in various colors is a requirement in artwork.

The ability to zoom in and out is an asset when drawing to scale. It is possible to work on fine detail in an assembly and then zoom out to observe the result in context.

CAD information is stored in digital form and hence, irrespective of the size of the final printed drawing, it is possible to accurately dimension components automatically.

Different 'type-set' and alternative style fonts are always supplied with CAD programs. If a special font is required to match an existing style then specialist vendors can supply. Alphabets in different languages present no problem. Quite clearly the physically largest affordable screen has many advantages. If the designer is also involved with desktop publishing, it is ideal to be able to work on a screen that displays two A4 paper sheets side by side so that 'what you see is what you get'. The screen should give high resolution. The quality of the display will have a big contribution to make in the avoidance of fatigue and eyestrain. Firsthand practical experience and a demonstration are important here for an ideal solution.

Plotting and printing equipment will vary according to design office requirements. A wide variety of plotters are available for reproductions from A4 to A0 in size, and in a quality suitable for production work or the most prestigious presentations.

Probably the best-known software in the design office is that from AutoCAD, which builds products that conform to the most widely used DWG format permitting the transfer of information between networks.

In the 1970s, 2D drawing packages were introduced with the ability to slowly draw lines, circles and text. Rapid developments have taken place since with a vast increase in computing power. The computer industry has expanded, progressed and now produces software for an ever increasing number of engineering applications. Computing power is vital for the operation of highly sophisticated research projects, and advanced design and modeling programs. Communication developments have had a profound effect regarding the methods that we use for our current solutions. We have the capability to transmit files

of drawings and notes from the computer screen for use by collaborative partners, and the Internet can transmit information around the world in seconds.

Solid models suitably animated can also be viewed in 3D to clarify detail and this can be a considerable asset where perhaps there is a change of language. User manuals for domestic equipment are commonly drawn in solid modeling programs to illustrate sequences of assembly and improve clarity for non-technical customers.

A very important part of work in the design office is dealing and handling revisions and modifications. Products which are continuously developing require modifications which use quite a large proportion of design office time so it is important that the CAD system being used enables efficient and configured modifications. Immediate transmission to all members of an associated group has considerable advantages. Examples here are recall notices for car owners and faulty items in domestic appliances.

There are many examples where various component parts are manufactured in different countries and brought together for assembly and testing. The aircraft industry is a typical case.

Drawings are reproduced in many sizes and small items present little difficulty with zoom facilities. Views drawn to different scales and a variety of orientations can be arranged on the same drawing print as an aid to comprehension.

## **Computer and software purchase**

It is strongly recommended that before any purchases are made, advice is sought from a recognized and authorized dealers, as they would be able to check that the equipment can perform the tasks you expect in your style of working. It is important to produce a list of tasks you want the software to perform including compatibility with Computer Aided Manufacturing (CAM) Computer Aided Inspection (CAI), Finite Element Analysis and Product Lifecycle Management Software. It is also advisable to understand what hardware will be required to run the software. Practical demonstrations are very necessary and it is strongly recommended that a benchmarking exercise of potential software is carried out before making a purchase. CAD equipment is a tool and there are possibly many ways of doing the same job so it is advisable to share your design to manufacture process with a supplier as they may well be able to suggest a more productive way using their product.

As mentioned above, the right hardware is important for efficient working, the cheapest is not often the best, reliability is key as downtime costs time and money. For peace of mind you should make sure you get a written specification for hardware and software indicating any other relevant equipment required for protection and safe operation. See Chapter 1 for additional organizational considerations when purchasing computer hardware and software.

## **Project development**

The reader will appreciate that the design of, for example, a large construction project from its conception, will involve technical input from architects and engineering

designers in a wide variety of associated disciplines. It is vital that all contributors to the overall scheme talk the same language and that only compatible computer software packages are in use for the separate areas of work. In addition, the management contractor must have access to the designs as work is in progress. Before the age of CAD, it was the practice to have countless meetings in order to coordinate progress.

Design obviously continues in steps, and in planning and construction work problems arise, and designers need to be in a position to make modifications to overcome them before progressing to the next phase.

A typical case study illustrating the activity associated with this type of work is the construction of the Civil Aviation Authority 'en-route' center, built at Southampton. This prestige building and installation controls all the air traffic passing through Britain's airspace and houses, controllers operating banks of electronic and computer equipment where only an efficiency of 100% is acceptable. The building services engineer must ensure that the environment to keep both controllers and equipment comfortable is maintained 24 h a day, seven days a week.

Due to the extensive use of computers at the center, a huge amount of electrical, heating, ventilating and air conditioning plant needed to be installed. Different specialist contractors were responsible for these services under the stewardship of the management contractor.

The fast track nature of the design and construction required an extensive application of CAD, where individual contractors responsible for electrical, mechanical, and ducting work were 'net-worked' on site and could refer to CAD data from each other.

At this development, it was accepted by contractors that for some drawings it was practical to work in three dimensions to make it easier, for example, to ensure clearances between piping and ductwork in the more cramped areas. Layout drawings in 3D permitted engineers to demonstrate clearly to other parties where, for example, electrical cables and conduits were likely to plow straight through heating and ventilation ducts. Potential problems were solved on screen rather than emerging during construction. In addition, adequate access for maintenance purposes and replacement of equipment could be confirmed. The designer can check designs by altering the angles from which arrangements are viewed on screen.

In the design of many heavy engineering plant layouts, it is often the practice to build a scale model of the plant as design work progresses. The function of the model is to keep a running check on the feasibility of the installation. Obvious improvements can then be incorporated.

Constructions of chemical plants and oil refineries are typical examples. After completion of the project, models may be used for publicity purposes and to assist in the education of technicians who operate and service the equipment. Three-dimensional modeling has many other applications in the film and entertainment industry and drawings in 3D can materially assist in comprehension.

When many workstations have to be installed for a design team, it is vital to agree on working methods. Recommendations for useful Standards in Construction Drawing Practice are detailed in Chapter 34.

Agreement is necessary on the organization of many aspects of work, and in CAD these include the use of layers, the groupings of the various sections of construction

designs, use of colors so that for example, similar ductwork appears on the screen in the same shade, procedures for the transfer of data between several drawing offices, methods of structuring data for archiving, and to help future retrieval. In the light that no national or international Standards exist, most organizations have produced their own specific CAD input Standards to meet their business requirements. The quality of all drawing work needs to be uniform and conform to BS 8888 for a complete understanding and to avoid ambiguity. It is essential that all contributors work as a team and in harmony if planning deadlines are to be kept, as, obviously, delays in one area of construction can holdup another contractor's work and might result in financial loss.

## Size of computer

As a rough guide to selection, the larger the drawing and degree of complexity, the more important is the performance and power of the computer and its operator.

If a drawing contains large areas which are cross hatched or shaded, for example, it is important to be able to redraw illustrations quickly to prevent time wasting. Equally, when designing using 3D software, the assembly of complex models requires high performance computers to enable real time manipulation of the assembly.

It is easy to obtain demonstrations of computer power and this is recommended. When selecting software products required to operate with each other, it is necessary to check compatibility; your supplier should advise.

You will appreciate from the applications mentioned above that associated specialist software is being developed all the time. The one certain aspect is that future trends will use applications needing greater amounts of computer memory, so the chosen system must be expandable. Consideration must also be given to the question of storing drawings, filing systems, backups and information retrieval.

Given the rapid progress and changes in the design office during the last 15 years the only prediction one can make is that the role of the designer, far from diminishing, is more important than ever.

## Parametric design

It is a common drawing office practice, where a range of parts are similar, to produce a single drawing with a table of dimensions for the features of each separate component. The user will then need to sort out the appropriate sizes of each detail relating to the part required. The drawing itself, being representative of a number of similar parts, cannot be drawn true to scale for them all.

A study of [Fig. 5.1](#) will show a special screw, which has a family of parts. It is defined on a single drawing where the main dimensions are expressed algebraically as ratios of the shank diameter of the screw and other relevant parametric values. For a given thread size and screw length, the CAD system is able to produce a true-to-size drawing of any

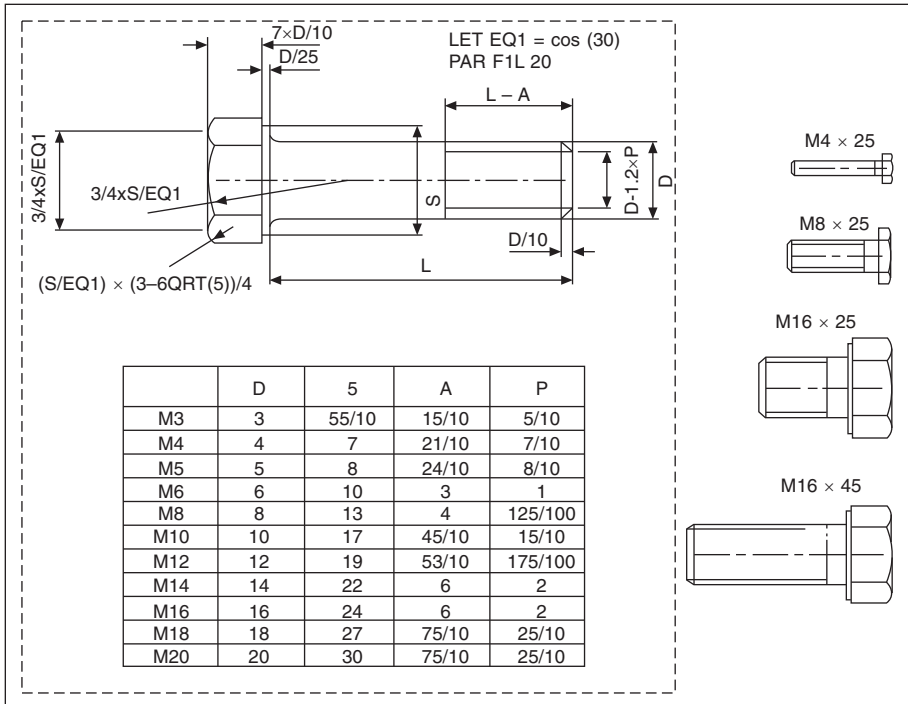


Fig. 5.1 Family of parts.

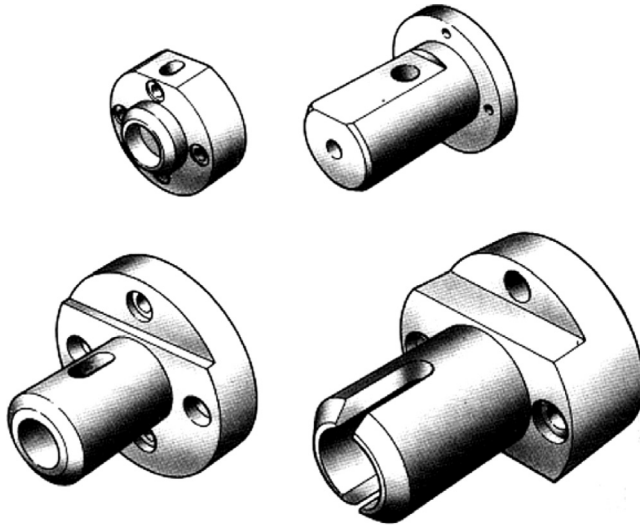
individual screw listed. This drawing may then be used as part of an assembly drawing, or fully dimensioned and suitable for manufacturing purposes. Four typical screws are indicated at the right-hand side of the illustration. It is always a positive advantage in design work to appreciate true sizes and use them in layouts.

Components such as bolts, nuts, washers, fasteners, spindles and seals fall naturally into families where similar geometric features are present. The parametric capability of the CAD system can be used to considerably improve productivity in this area of drawing office work.

It is not an uncommon practice in product development to modify existing Standard components if possible and use them as the basis for new ones. Notice the visible connection between the features of the four components illustrated in Fig. 5.2. This is a further example of parametrication where the principles of variational geometry have been applied.

The family of parts is constructed from a large and small cylinder with different diameters, lengths and central bore sizes. A chamfer at the left-hand end, a vertical hole extending into a slot and a flat surface at the top are added details.

Parametric systems handle the full range of linear and angular dimensions including degrees and minutes. The computer will also calculate maximum and minimum limits of size from specified tolerance values. Dimensions can be defined numerically or as algebraic expressions. You can avoid the need to dimension every fillet radius for



**Fig. 5.2** Parametrication of variational geometry.

example by setting a default value for radii. This means that, unless a specific value is stated for a particular radius on a part, it will automatically be drawn at a previously agreed size. Where many radii are present, as in the case of casting work, this feature is a considerable aid to drawing office productivity. A number of such defaults can be entered, to cover a variety of applications.

Areas of detail within a drawing, which are not required to be parametricated, can be excluded by enclosing them in a group line and this avoids the need to dimension every detail. The geometry contained in the enclosed group may remain static or magnified when the part is parametricated.

A further advantage of expressing dimensional values in algebraic form allows the designer to simulate the movement of mechanisms and produce loci drawings of specific points. It is essential in the design of mechanisms to appreciate the path taken by every point, which moves.

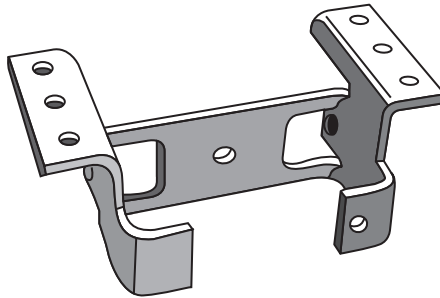
## Sheet metalwork application

The design of components to be manufactured from folded sheet metal is a field in which CAD systems can offer great assistance.

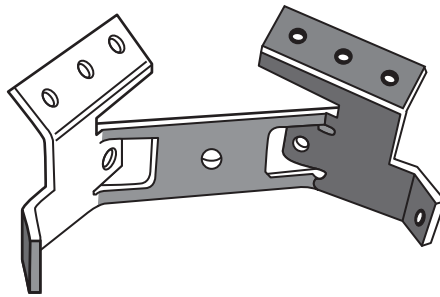
In the case of the bracket shown in [Fig. 5.3](#) it would first be necessary to establish the overall dimensions of the part.

The second step would be to imagine that the bracket is folded back gradually as indicated in [Fig. 5.4](#) into the flat sheet form. This shape can then be cut from the stock material.

The dimensions of the flat pattern have to make allowance for the bend radius, the metal thickness and the type of metal used. Metals behave quite differently when bent



**Fig. 5.3** 3D view of a bracket.



**Fig. 5.4** Bracket partially developed.

and the CAD system can be programmed to calculate an appropriate bend allowance. After the developed shape has been cut, the bracket can be folded with suitably radiused bends.

The design can be checked for material accuracy, weight, volume, and so on, before being committed to manufacture.

## Pipework systems

There are many aspects of pipework draughting where the computer can considerably improve productivity. In many cases, by using 3D modeling software the design can be partly automated.

Having received an order to construct the plant, pipework systems basically require two types of drawings: flow charts and services drawings. Flow charts are functional diagrams showing the scheme and will include major items of plant. This diagrammatic arrangement is not to scale but shows the relative positions of main items and the connections between them. The diagram illustrates the feasibility of the system.

Equipment may be fixed at various levels. Assuming that a factory is to be built, then separate areas will be allocated to individual teams of designers who prepare layouts and services drawings for structural work, manufacturing areas, heating, ventilation, air

conditioning, compressed air, and electrical services, etc. It is a standard practice to aid installation, and to eliminate a clash of services, coordinated services drawings are produced. These drawings combine all relative services which are dimensioned relative to fixed datums (see below). Ground site surveys are undertaken and various datum levels established to act as benchmarks for reference measurements. Steelwork can now be designed for the factory and manufactured to suit the site contours.

A 3D scale drawing could be constructed showing separate levels on which the items of plant are mounted. Straight lines representing the centrelines of interconnecting pipework are added. Pipes are sized to ensure adequate flow of liquids or gases and to withstand the pressure exerted by the contents. Realistic pipework can now be added. Suitable bends, elbows and other fittings may be directly 'dragged and dropped' at the various corners where pipes change directions and levels.

Software is available with libraries of ready-made standard fittings. Note carefully, however, which Standards are applicable. ISO and US Standards are regularly used and specifications need to be checked. The drawing office will be responsible for preparing lists and schedules of equipment required for fabrication and the following are typical:

- Pipe lists quoting sizes and lengths taking into account bend radii. During erection, pipes are cut to length then welded into the pipelines.
- Lists of similar standard bends and elbows.
- Lists of similar welded joints and processes.
- Lists of unions joining pipes together for non-welded constructions.
- Valves of all different types, sizes and connections, i.e. screwed, bolted and welded.
- Hangers to support pipework and expansion devices to permit movement.
- Pumps and associated fittings.
- Instrumentation devices, pressure gauges, temperature measuring devices and flow meters, and filters.
- Equipment will be ordered from manufacturers using these records and costs calculated.

Another vital task that the computer can determine is to check clearances where pipes cross to ensure that there is an adequate space to allow erection and operation.

The above are typical process tasks that can be handled by piping software.

## **Communicating design concepts**

### ***Mockups and prototypes***

Mockups and prototypes show how products and mechanisms look and perform but building them is a time-consuming process. A 3D model is life-like, popular and can be of considerable assistance for publicity purposes especially where the client has limited technical experience. Recent developments are easy to use and an economical method of demonstrating engineering design concepts.

Drawings can be communicated by email and have the advantage that they can be viewed by anyone who has a PC. Products can be rotated through 360° to show how

they appear from any angle so that movement through their cycle of operations can be demonstrated. Simulation may be sufficient to reduce the need for expensive prototypes.

Maximized sales and marketing opportunities may result from presenting new and novel product designs more effectively to customers and business prospects.

Models can shorten development cycles and assist in fast product design changes.

Animated drawings give you the opportunity to explode or collapse an assembly to demonstrate how the components fit together.

Rapid prototyping or Additive manufacturing has become widely used to produce physical models to aid conveying design intent. Rapid prototyped models are invaluable at design reviews or for use in market testing of products. Derived from 3D models Additive Manufacturing methods such as 3D Printing (using a starch based powder and inkjet technology) are relatively inexpensive and are ideal for producing good quality, 'touchy-feely' models which, although at times can be fragile, are an excellent aid to any design review. Stereolithography (liquid resin cured by laser), Selective Laser Sintering (thermoplastic powder fused by laser) and Fused Deposition (hot extruded thermoplastic) methods are more expensive but produce models which are more robust and can be used to make functional prototypes without the costs of expensive tooling. Additive Manufacturing has progressed a long way in the last 10 years and the development of new modeling materials has elevated the technique to a full production capability (see Chapter 39).

Confidence in a particular project also results from confirmation that it is acceptable and suitable in the market place.

## ***Production***

Many products require a considerable amount of testing. Safety is always vital and must be the top priority.

It needs to be remembered that all products must be designed so that the production department can economically manufacture them. The design must also be suitable for easy assembly, disassembly, repair/maintenance and end of life processing (see chapter 3 for more details). Financial constraints should never be forgotten; hence meticulous care is taken in pre-production phases to reduce the time-to-market and eliminate modifications to the product, once mass production begins.

## ***Rendering controls***

Presentations and proposals using photo-realistic images add excitement and visual impact. Before applying rendering features to a model, the background and lighting conditions should be adjusted to simulate mood, time and scene composition. Lighting, shadows and ray tracing for reflective and transparent materials can also be applied, and if required, background scenery.

Smoothing areas of high contrast to improve appearance can enhance image quality. Accuracy is improved through fully associative design. Mating constraints are preserved along with the relationships between parts and assemblies. Drawings update automatically. Errors may be prevented and designs optimized by using Collision Detection to observe in real time how moving parts interact. Visualization may be improved with enhanced graphical control of lights. Photo-realistic effects may also be created by means of sophisticated ray-traced lighting. It is also possible to analyze the complete history of the design project and document an automated design process.

The rendering mode quickly displays a shaded image of the model with materials attached. It is often convenient to save alternative production quality images of your design for comparison purposes and use in other associated design projects. Alternative views can be a valuable and visible asset during training programs.

## Materials options

Visual effects from libraries of life-like textures and materials can be added to 3D models easily, using commands available on the toolbar menu. Libraries are available with a wide selection of plastics, metals, woods, stones, and other textured materials which can be applied to entire parts, features, or individual faces. Realistic changes can also be made to suggest surface reflectance, roughness, transparency, and an irregular or indented appearance (see [Fig. 5.5](#)).



**Fig. 5.5** Chrome vanadium steel square drive socket wrench showing examples of reflectance, roughness and indented appearance.

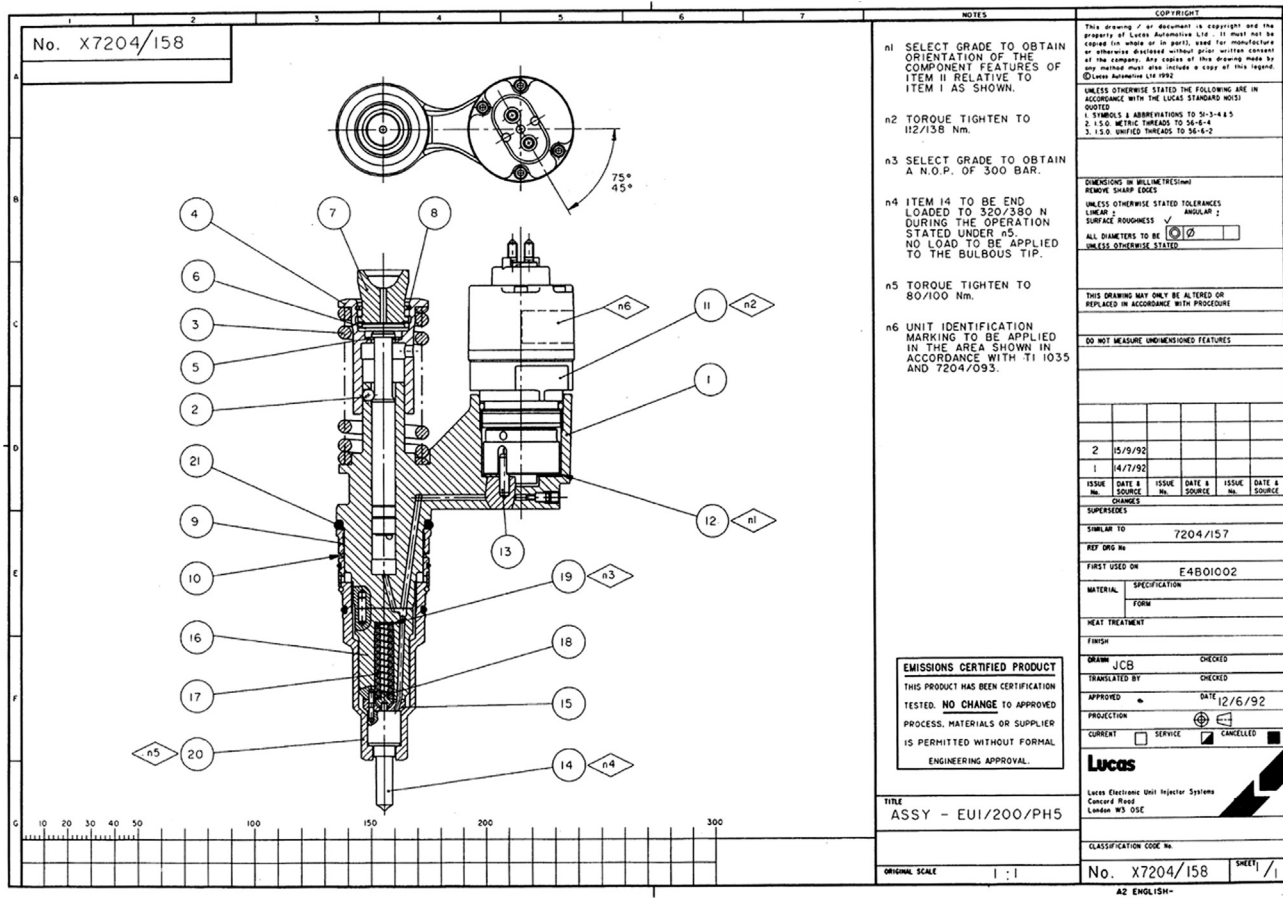


Fig. 5.6 An assembly drawing of a fuel injector for a diesel engine.

---

Fig. 5.6 shows an assembly drawing of a fuel injector for a diesel engine. Drawn to BS and ISO Standards, this is a typical professional CAD drawing which could be produced using most CAD software on the market. In industry, it is now common practice to include a small axonometric representation of the product, placed in a corner of the drawing, to aid its reading.

# Principles of first and third angle orthographic projection

# 6

## First angle projection

Assume that a small block is made  $35\text{ mm} \times 30\text{ mm} \times 20\text{ mm}$  and that two of the corners are cut away as shown below in three stages (Fig. 6.1).

Fig. 6.2 illustrates a pictorial view of the block and this has been arranged in an arbitrary way because none of the faces is more important than the others. In order to describe the orthographic views, we need to select a principal view and in this case we have chosen the view in direction of arrow A to be the view from the front.

The five arrows point to different surfaces of the block and five views will result. The arrows themselves are positioned square to the surfaces, that is at  $90^\circ$  to the surfaces and they are also at  $90^\circ$ , or multiples of  $90^\circ$ , to each other. The views are designated as follows:

- View in direction A is the view from the front.
- View in direction B is the view from the left.
- View in direction C is the view from the right.
- View in direction D is the view from above.
- View in direction E is the view from below.

In first angle projection the views in the directions of arrows B, C, D, and E are arranged with reference to the front view as follows:

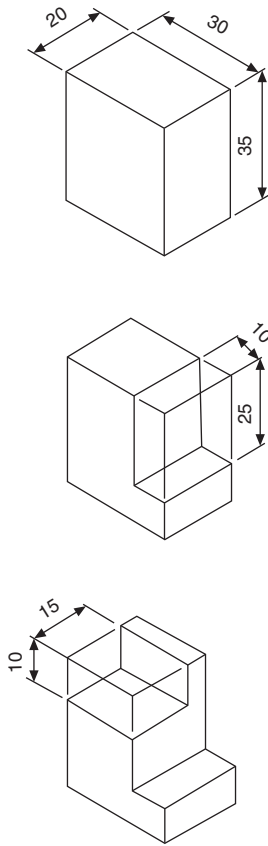
- The view from B is placed on the right.
- The view from C is placed on the left.
- The view from D is placed underneath.
- The view from E is placed above.

The experienced designer will commit the above rules to memory. It is customary to state the projection used on orthographic drawings to remove all doubt, or use the distinguishing symbol which is shown on the arrangement in Fig. 6.3.

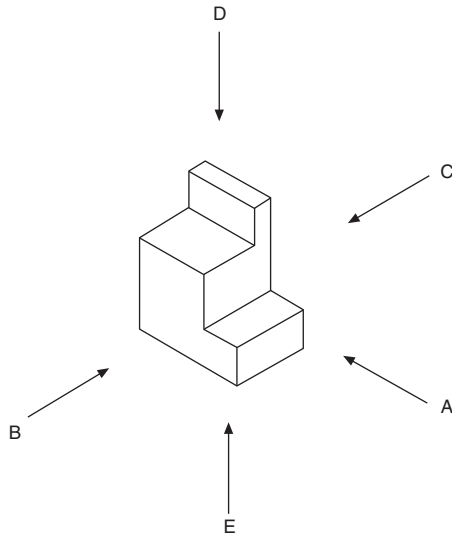
## Third angle projection

The difference between first and third angle projection is in the arrangement of views and, with reference to the illustration in Fig. 6.4, views are now positioned as follows:

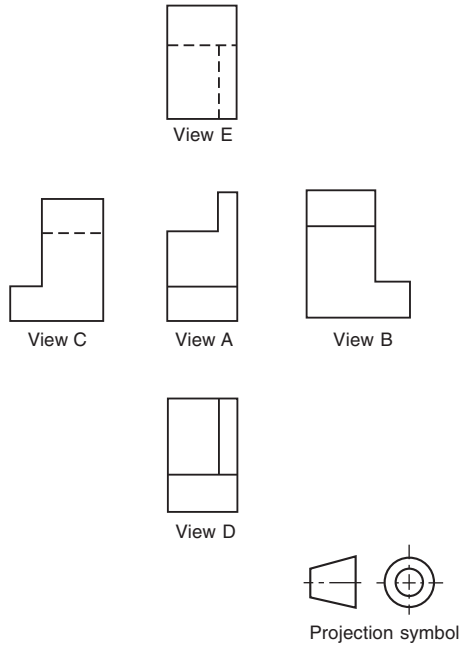
- View B from the left is placed on the left.
- View C from the right is placed on the right.
- View D from above is placed above.
- View E from below is placed underneath.



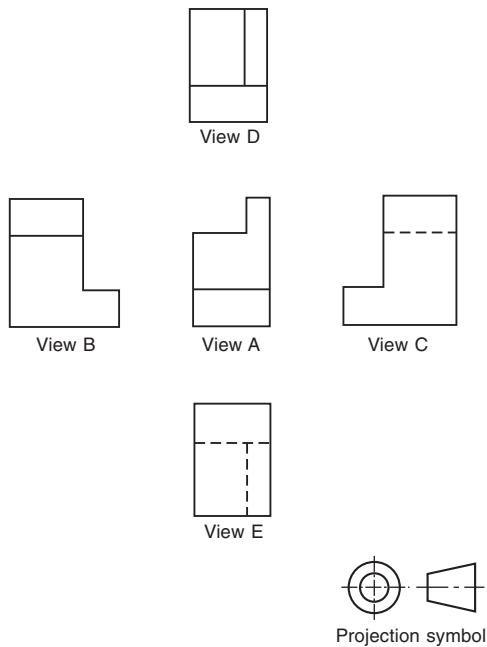
**Fig. 6.1** Cut away block.



**Fig. 6.2** Pictorial view.



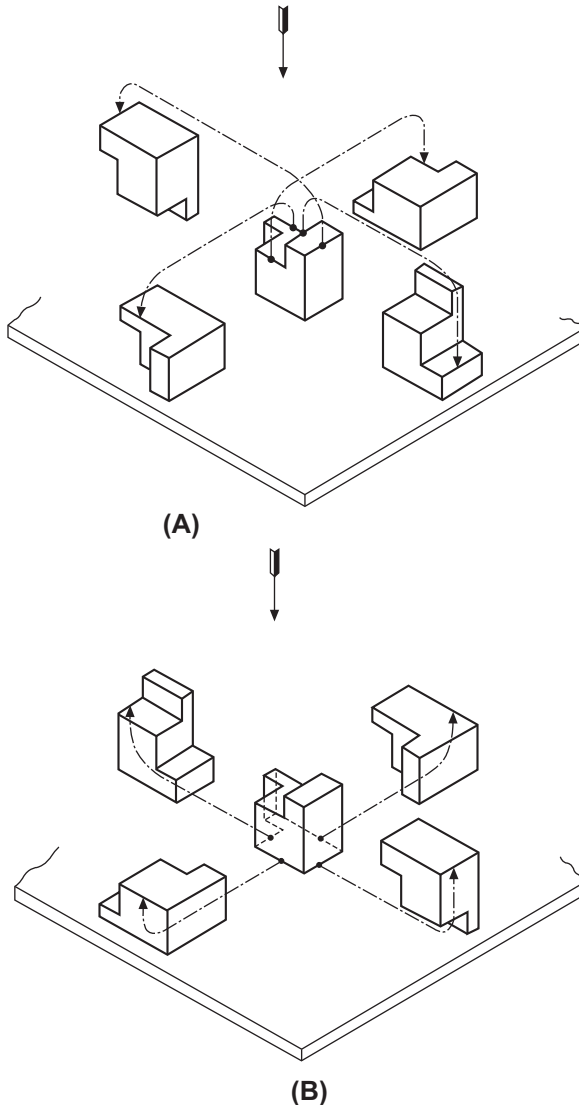
**Fig. 6.3** First angle projection arrangement. Dotted lines indicate hidden edges and corners.



**Fig. 6.4** Third angle projection arrangement.

Study the rearrangement shown in Fig. 6.4 and remember the above rules because it is vital that the principles of first and third angle projection are understood. The distinguishing symbol for this method is also shown.

If a model is made of the block shown in Fig. 6.1, and this can easily be cut from polystyrene foam used in packing, then a simple demonstration of first and third angle projection can be arranged by placing the block on the drawing board and moving it in the direction of the four chain dotted lines terminating in arrows in Fig. 6.5A shows the positioning for first angle and Fig. 6.5B for third angle projection. The view in each case in the direction of the large arrow will give the five views already explained.

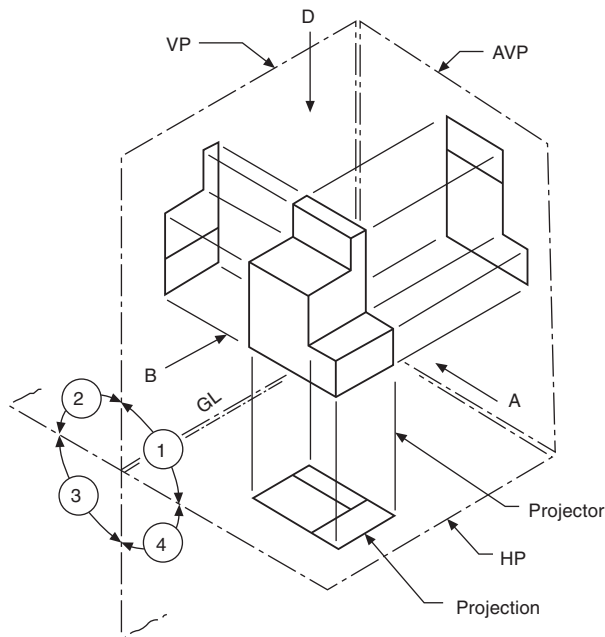


**Fig. 6.5** (A) First angle arrangement. (B) Third angle arrangement.

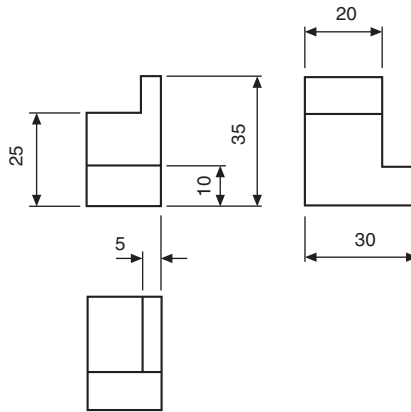
The terms first and third angle correspond with the notation used in mathematics for the quadrants of a circle; in Fig. 6.6 the block is shown pictorially in the first quadrant with three of the surfaces on which views are projected. The surfaces are known as planes and the principal view in direction of arrow A is projected on to the principal vertical plane. The view from D is projected on to a horizontal plane. View B is also projected on to a vertical plane at  $90^\circ$  to the principal vertical plane and the horizontal plane and this is known as an auxiliary vertical plane. Another horizontal plane can be positioned above for the projection from arrow E, also a second auxiliary vertical plane on the left for the projection of view C. Notice that the projections to each of the planes are all parallel, meeting the planes at right angles and this is a feature of orthographic projection.

The intersection of the vertical and horizontal planes gives a line which is the ground line GL. This line is often referred to as the XY line; this is useful in projection problems since it represents the position of the horizontal plane with reference to a front view and also the position of the vertical plane with reference to a plan view. Many examples follow in the text.

If the planes containing the three views are folded back into the plane of the drawing board, then the result is shown in Fig. 6.7 where dimensions have also been added. The designer adjusts the distances between views to provide adequate spaces for the dimensions and notes.



**Fig. 6.6** VP is the vertical plane. HP is the horizontal plane. AVP is the auxiliary vertical plane. GL is the ground line.



**Fig. 6.7** First angle projection with dimensions added.

To describe a simple object, a designer does not need to draw all five views and it is customary to draw only the minimum number which completely illustrates the component. You will note in this particular case that we have omitted views which contain dotted lines in preference to those where corners and edges face the observer. Many parts do not have a definite 'front', 'top', or 'side' and the orientation is decided by the designer, who selects views to give the maximum visual information.

Traditionally, front views are also known as front elevations, side views are often known as side or end elevations, and the views from above or beneath are referred to as plans. All of these terms are freely used in industrial drawing offices.

## Projection symbols

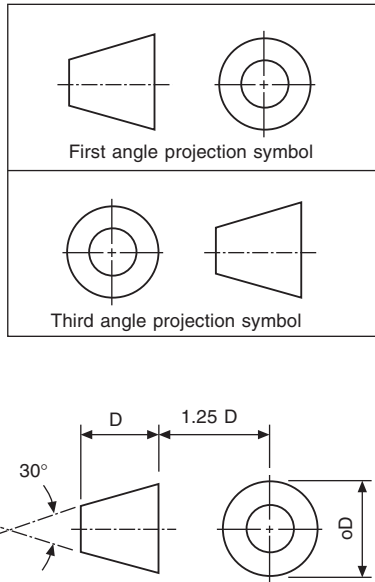
First angle projection is widely used throughout all parts of Europe and often called European projection. Third angle is the system used in North America and alternatively described as American projection. In the British Isles, where industry works in co-operation with the rest of the world, both systems of projection are regularly in use. The current British and ISO Standards state that these two systems of projection are equally acceptable but they should never be mixed on the same drawing. The projection symbol must be added to the completed drawing to indicate which system has been used.

[Fig. 6.8](#) shows the recommended proportions of the two projection symbols.

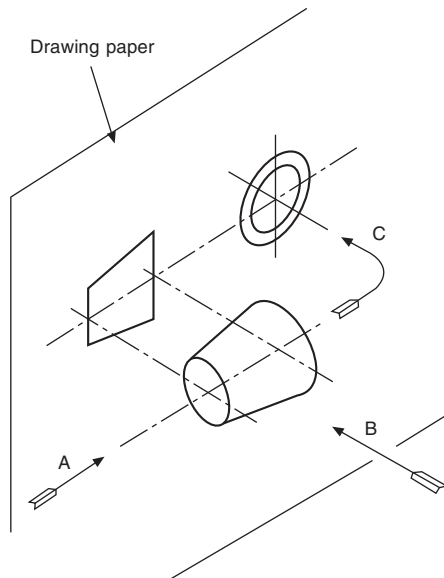
[Fig. 6.9](#) indicates how the first angle symbol was obtained from projections of a tapered roller. The third angle alternative is given in [Fig. 6.10](#).

Please note the movement suggested by the arrow in [Fig. 6.9](#) and [6.10](#) and also in [Fig. 6.8](#), since orientation is the main clue to understanding the fundamental differences in projection systems.

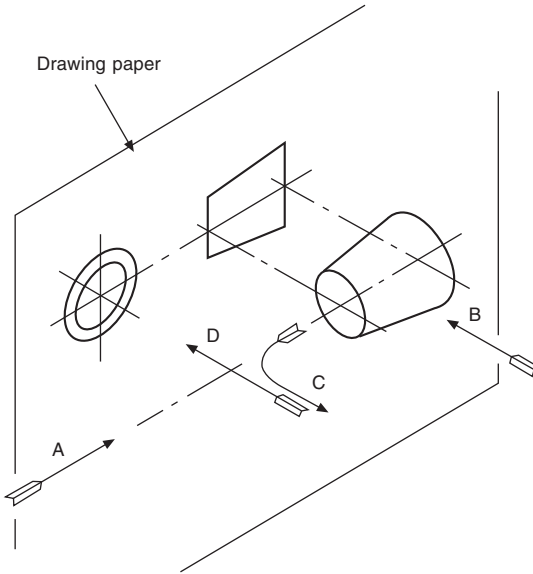
An experienced designer must be fully conversant with all forms of orthographic and pictorial projection and be able to produce a drawing where no doubt or ambiguity relating to its interpretation can exist.



**Fig. 6.8** Projection symbol proportions.



**Fig. 6.9** First angle symbol projection.



**Fig. 6.10** Third angle symbol projection.

## Drawing procedure

Generally, industrial draughtsmen do not complete one view on a drawing before starting the next, but rather work on all views together. While projecting features between views, a certain amount of mental checking takes place regarding shape and form, and this assists in accuracy. The following series of drawings shows stages in producing a typical working drawing in first angle projection.

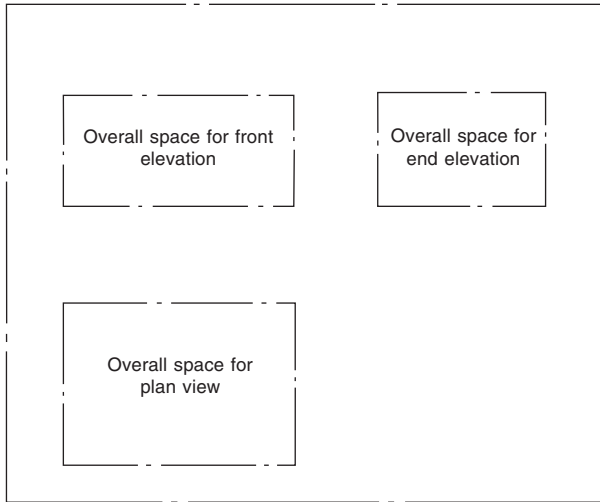
*Stage 1 (Fig. 6.11):* Estimate the space required for each of the views from the overall dimensions in each plane, and position the views on the available drawing sheet so that the spaces between the three drawings are roughly the same.

*Stage 2 (Fig. 6.12):* In each view, mark out the main center lines. Position any complete circles, in any view, and line them from the start, if possible. Here complete circles exist only in the plan view. The heights of the cylindrical features are now measured in the front view and are projected over to the end view.

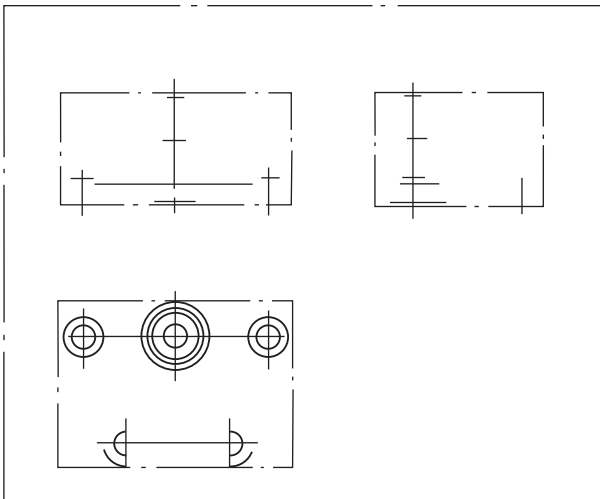
*Stage 3 (Fig. 6.13):* Complete the plan view and project up into the front view the sides of the cylindrical parts.

*Stage 4 (Fig. 6.14):* Complete the front and end views. Add dimensions, and check that the drawing (mental check) can be redrawn from the dimensions given; otherwise the dimensioning is incomplete. Add the title and any necessary notes.

It is generally advisable to mark out the same feature in as many views as is possible at the same time. Not only is this practice time-saving, but a continuous check on the correct projection between each view is possible, as the designer then tends naturally to think in the three dimensions of length, breadth, and depth. It is rarely advantageous to complete one view before starting the others.



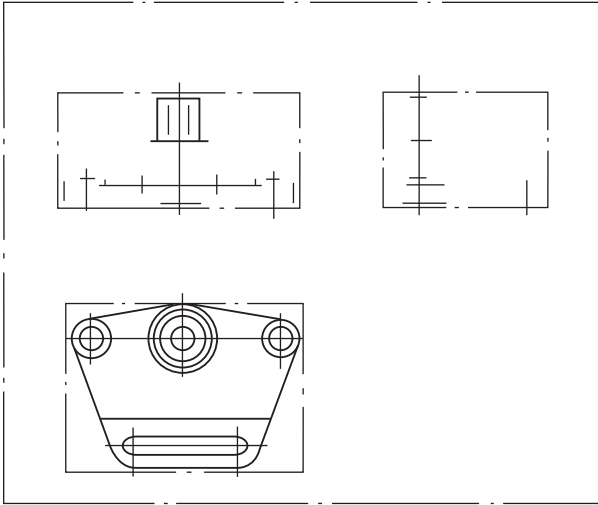
**Fig. 6.11** Stage 1.



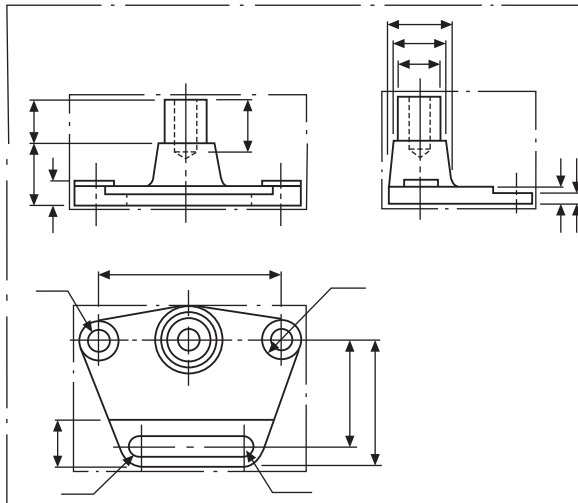
**Fig. 6.12** Stage 2.

## Reading engineering drawings

The following notes and illustrations are intended to assist in reading and understanding simple drawings. In all orthographic drawings, it is necessary to project at least two views of a three-dimensional object — or one view and an adequate description in some simple cases, a typical example being the drawing of a ball for a bearing. A drawing of a circle on its own could be interpreted as the end elevation of a cylinder or a sphere. A drawing of a rectangle could be understood as part of a bar of rectangular cross-section, or it might be the front elevation of a cylinder. It is therefore generally necessary to



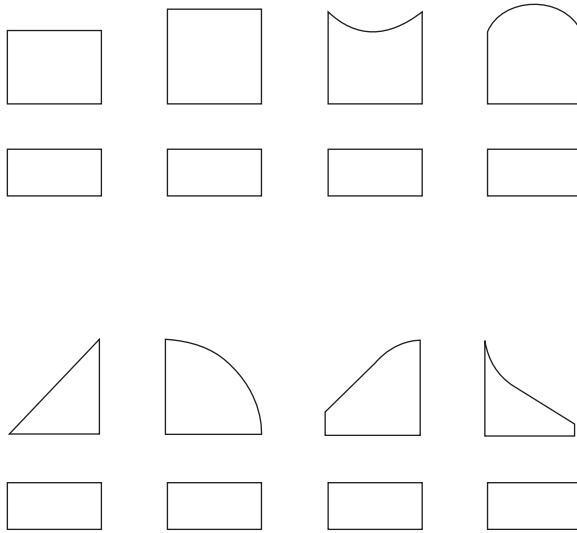
**Fig. 6.13** Stage 3.



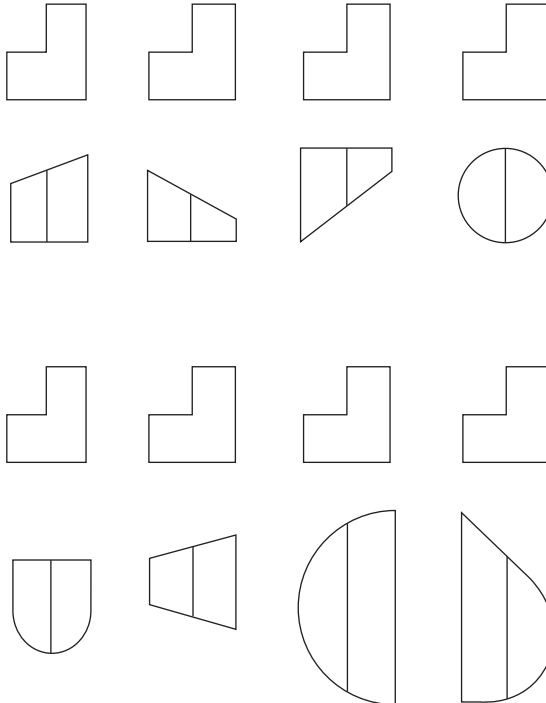
**Fig. 6.14** Stage 4.

produce at least two views, and these must be read together for a complete understanding. Fig. 6.15 shows various examples where the plan views are identical and the elevations are all different.

A single line may represent an edge or the change in direction of a surface, and which will be determined only by reading both views simultaneously. Fig. 6.16 shows other cases where the elevations are similar but the plan views are considerably different.



**Fig. 6.15** Identical plan views with different elevations.



**Fig. 6.16** Similar elevations with different plan views.

A certain amount of imagination is therefore required when interpreting engineering drawings. Obviously, with an object of greater complexity, the reading of three views, or more, may well be necessary.

## Projection exercises

It is clear to us that after teaching draughting and CAD for many years, visualizing a proposed new product in three dimensions, which is how you naturally view a finished article, is difficult when it is necessary to read more than one complex two-dimensional drawing simultaneously. The designer also ultimately needs to produce technically correct drawings, often from vague initial ideas. The very action of making proposal drawings stimulates many questions and their answers allow development to continue. Modifications to original ideas involve drawing amendments, and changes to one view invariably have a 'knock on effect'. Comprehension, understanding, and the ability to read technical drawings fluently come with practice.

The following simple exercises are designed to assist in the perfection of draughting skills. They are equally suitable for CAD and the drawing board. Produce answers for each series and select standard sizes of drawing sheets, taking particular care with line-work and layout.

If the CAD software program permits, move the separate views for each exercise so that they are positioned a similar distance from each other. Then experiment and position the groups to give a pleasing layout on the drawing sheet. Note how uniformity can improve presentation and give a professional appearance. Layout is a very important aspect when preparing drawings for desktop publishing applications.

### ***Straight line examples***

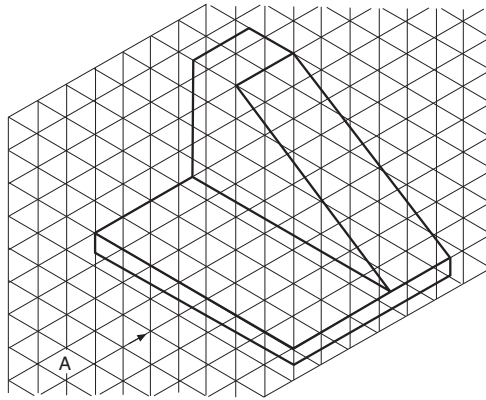
Fig. 6.17 shows three components in which each has been machined from solid blocks. These examples have been prepared on a grid formed by equilateral triangles.

In every case, the scale is such that each side of the triangle will be 10 mm. For each component, draw five views in first angle projection, omitting hidden detail, and assume that the view in the direction of the arrow A will be the front view.

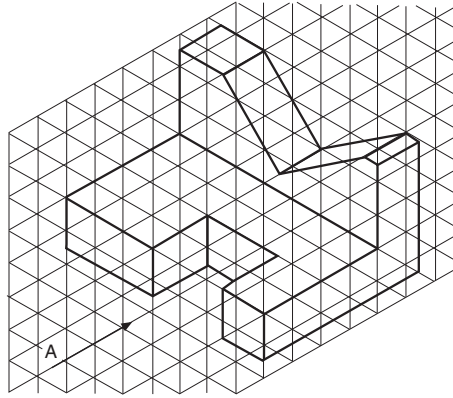
### ***Examples involving radii and holes (Fig. 6.18)***

For each example, project five views in first angle projection, taking the view in the direction of the arrow A as the front view. Hidden detail is required in the solutions to these problems, and note that in some cases the position of some of the holes will be found to coincide with center lines. Where this occurs, the dotted line should take priority. Take each side of the grid triangle to be 10 mm in length.

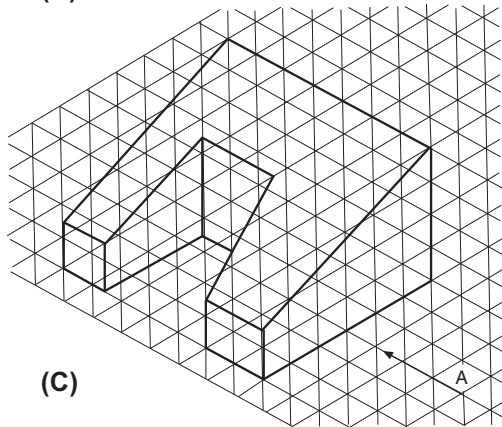
If only three views of each component were required, which one would you choose? The professional designer would select a front view, end view, and plan view with the least number of dotted lines. Study your solutions carefully and where an ideal choice exists, box this solution with a thin chain line. In some cases more than one choice can be made and these are indicated in the solutions.



(A)



(B)



(C)

Fig. 6.17 Examples with straight lines.

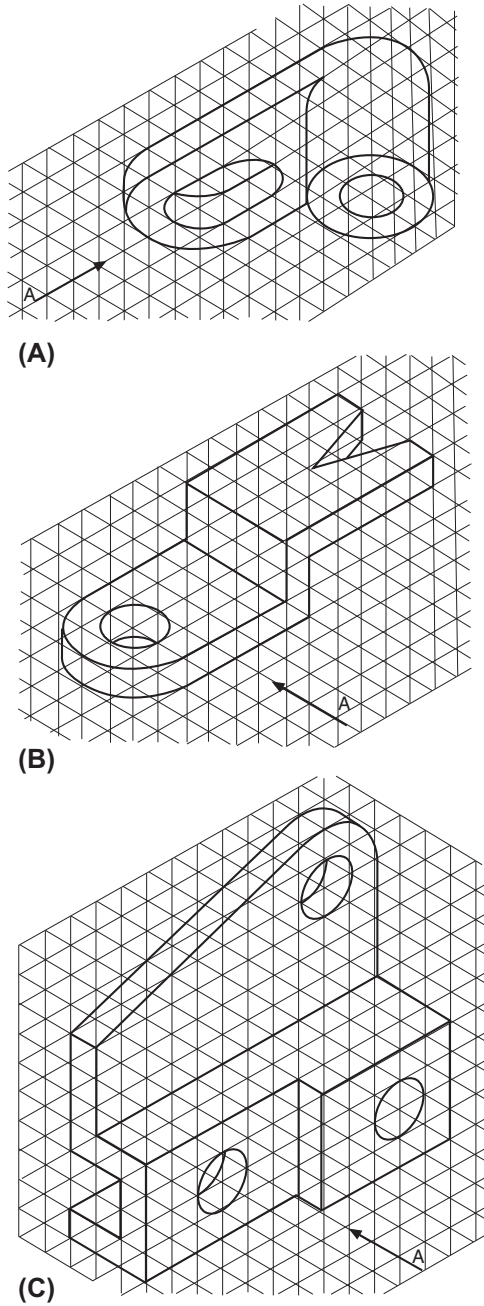


Fig. 6.18 Examples with radii and holes.

### ***Examples with missing lines (first angle projection) (Fig. 6.19)***

In the following projection examples, three views are given. Some views are incomplete with full lines and all dotted lines missing. Draw the given examples, using the scale provided. Complete each view, by inserting full lines where necessary and add all dotted lines to represent the hidden detail.

### ***Examples with missing views (first angle projection) (Fig. 6.20)***

In each of the following projection examples, two out of three views of simple solid components are shown. Draw the two views which are given using the scale provided. Complete each problem by drawing the missing view or plan in the space indicated by the cross.

### ***First angle projection examples with plotted curves (Fig. 6.22)***

In orthographic projection, all widths in the end view are equal in size to depths in the plan view, and of course the opposite is true that some dimensions required to complete end views may be obtained from given plan views. Fig. 6.21 shows part of a solid circular bar which has been cut at an angle of  $30^\circ$  with the horizontal axis. Point A is at any position along the sloping face. If a horizontal line is drawn through A across to the end view then the width of the chord is dimension X. This dimension is the distance across the cut face in the plan view and this has been marked on the vertical line from A to the plan. If this procedure is repeated for other points along the sloping face in the front view then the resulting ellipse in the plan view will be obtained. All of the examples in this group may be solved by this simple method.

A word of warning: do not draw dozens of lines from points along the sloping face across to the end view and also down to the plan view before marking any dimensions on your solution. First, you may be drawing more lines than you need, and in an examination this is a waste of time. Secondly, confusion may arise if you accidentally plot a depth on the wrong line. The golden rule is to draw one line, plot the required depth and then ask yourself 'Where do I now need other points to obtain an accurate curve?'. Obviously, one needs to know in the plan view the position at the top and bottom of the slope, and the width at the horizontal center line and at several points in between.

In the examples shown in Fig. 6.22 three views are given but one of them is incomplete and a plotted curve is required. Redraw each component using the scale provided. Commence each solution by establishing the extreme limits of the curve and then add intermediate points.

### ***Pictorial sketching from orthographic views***

Fig. 6.23 shows six components in first angle projection. Make a pictorial sketch of each component and arrange that the corner indicated by the arrow is in the foreground. No dimensions are given but estimate the proportions of each part assuming that the largest dimension in every example is 100 mm.

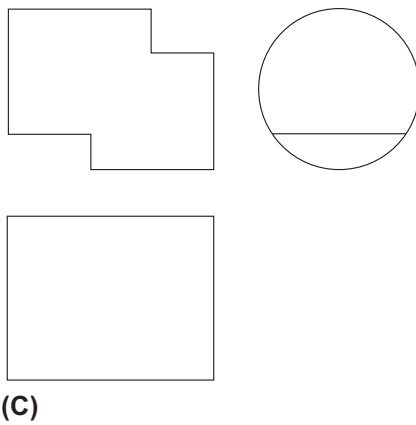
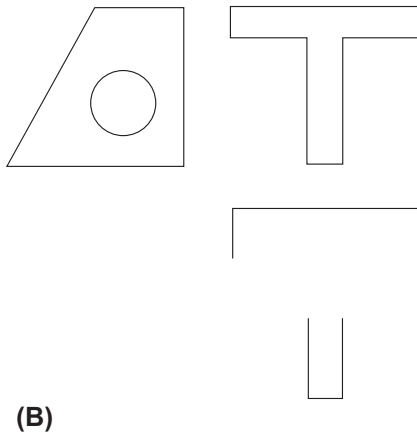
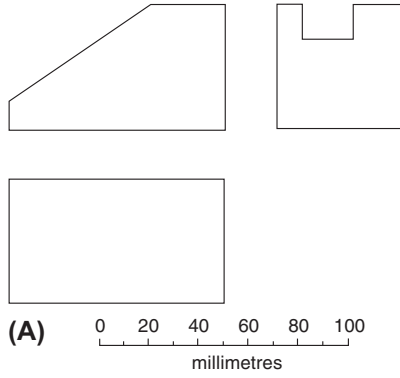


Fig. 6.19 Examples with missing lines.

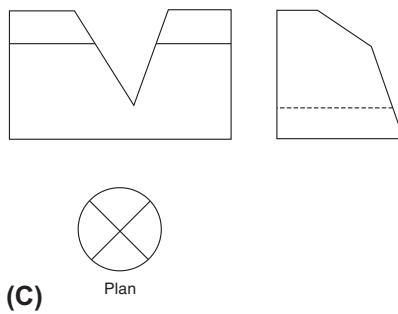
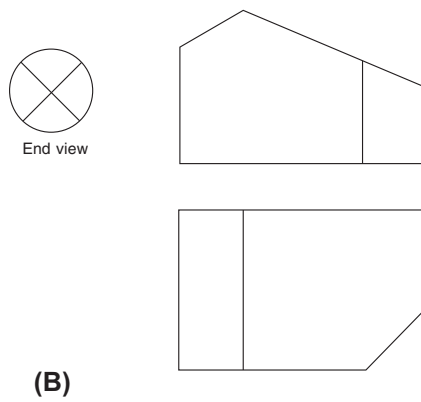
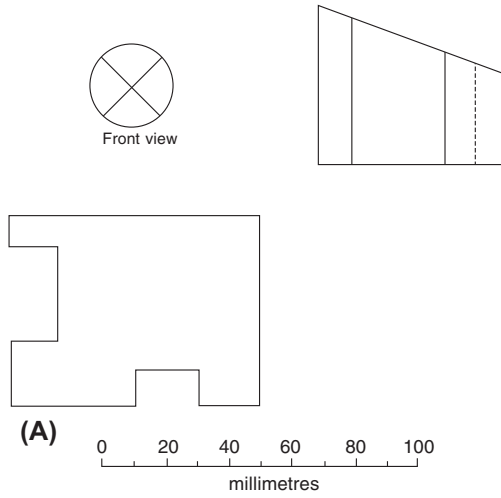
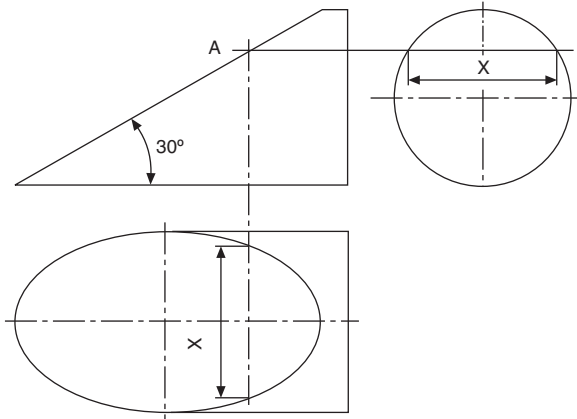
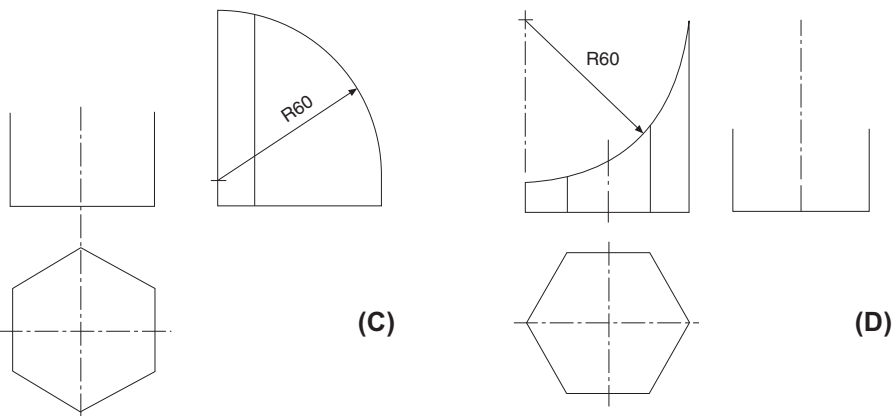
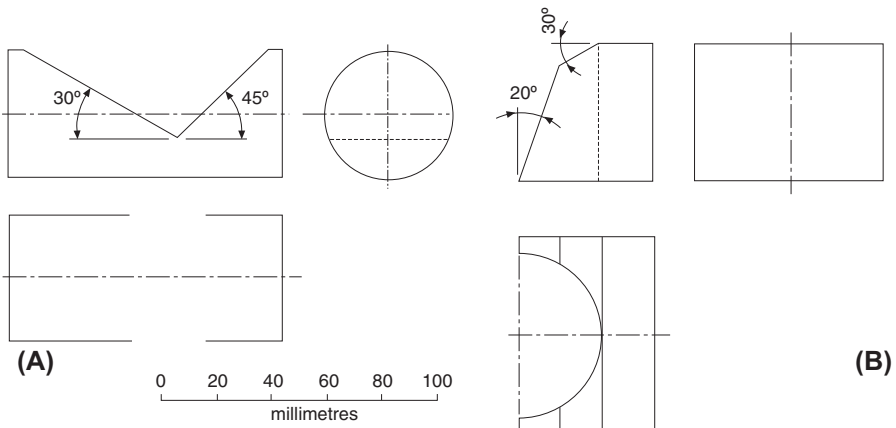


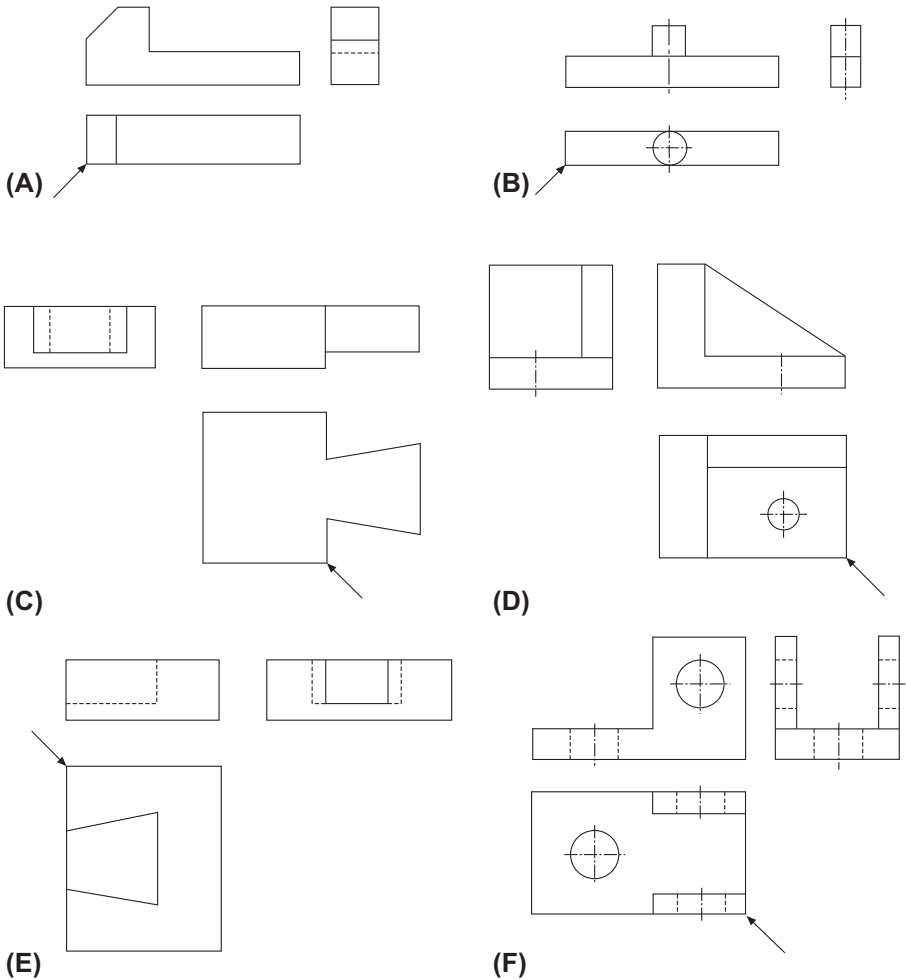
Fig. 6.20 Examples with missing views.



**Fig. 6.21** Circular bar cut at 30°.



**Fig. 6.22** Examples with plotted curves.



**Fig. 6.23** Components in first angle projection.

***Geometric solids in third angle projection***

Fig. 6.24 shows three views of each of three geometric solids. Sufficient dimensions are given to define the shapes but in each case two of the views are incomplete. Redraw the details provided and complete the views in third angle projection.

***Sectional views in third angle projection***

In Fig. 6.25 there are three components and two views are provided for each one. Copy the views given, using the scale provided, and project the missing view which will be a section. Your solution should include the section plane, cross hatching, and the statement A–A.

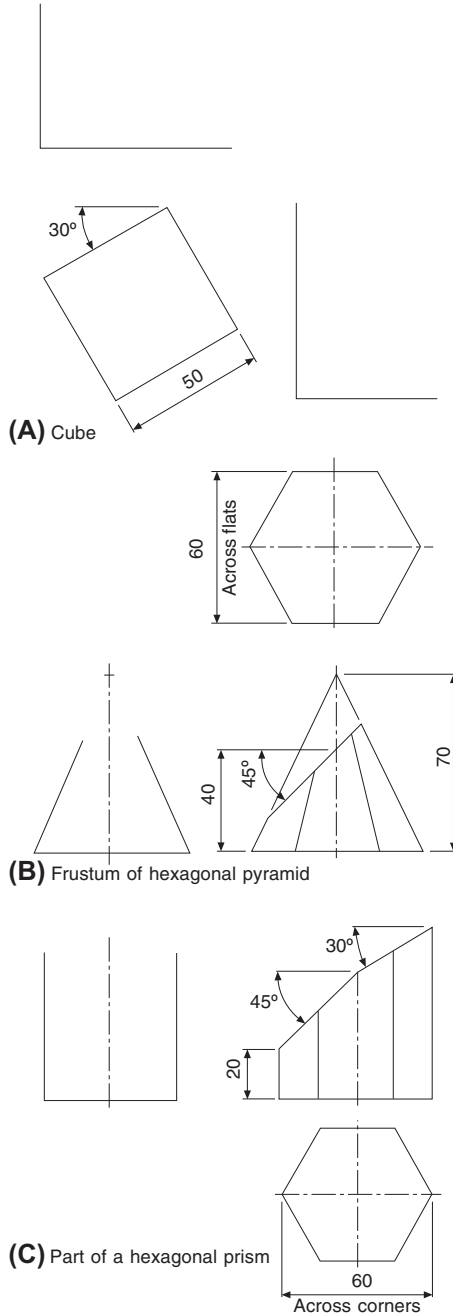
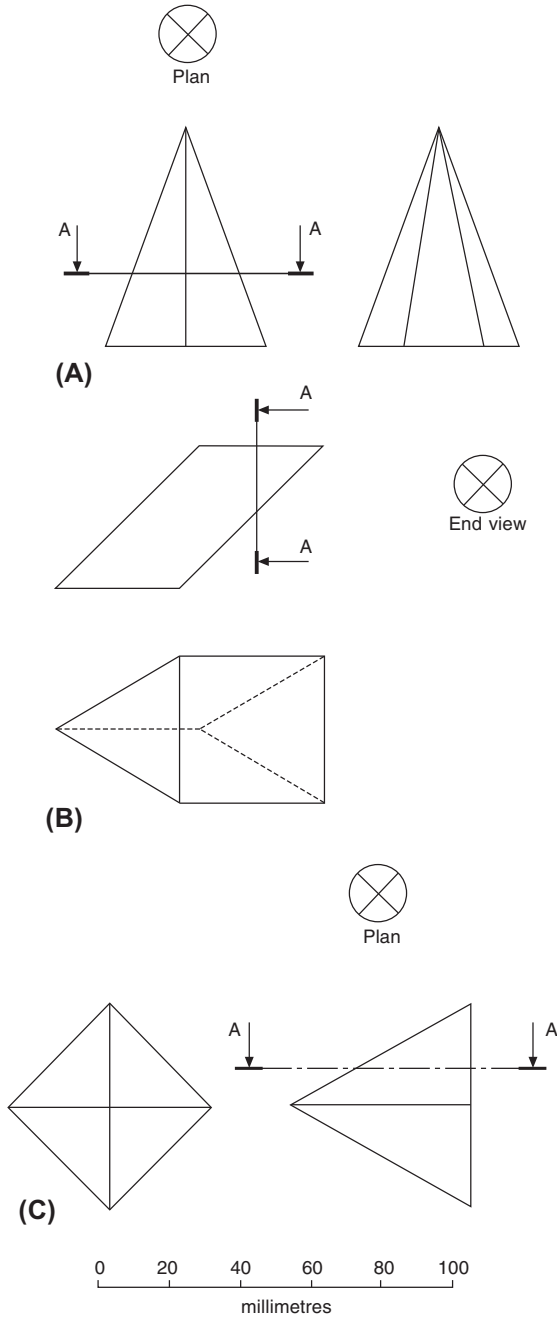
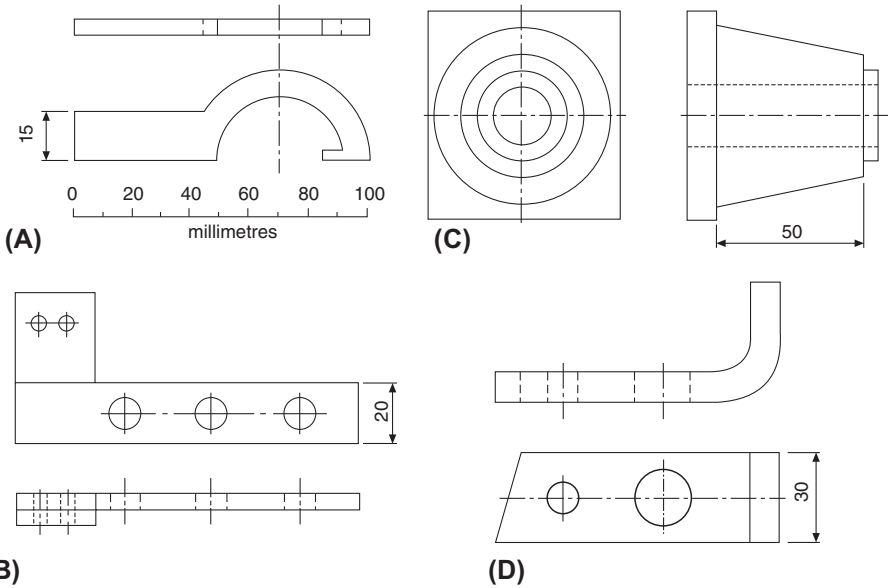


Fig. 6.24 Views of geometric solids.



**Fig. 6.25** Sectional views in third angle.



**Fig. 6.26** Examples to be dimensioned.

### ***Dimensioning examples (first angle projection)***

In [Fig. 6.26](#) a scale is provided to enable each of the components to be redrawn. Redraw each example and add any dimensions which you consider necessary and which would be required by the craftsman. Bear in mind that if an object has sufficient dimensions to enable it to be drawn, then it can most likely be made. Hence, any sizes which are required to enable you to draw the part are also required by the manufacturer. For additional information regarding dimensioning refer to Chapter 16.

# Linework and lettering

# 7

## Drawing paper sizes

The British Standard BS 8888 recommends that for normal practical purposes the area of the largest sheet is  $1 \text{ m}^2$  and the sides are in the ratio of  $1:\sqrt{2}$ . The dimensions of the sheet are  $841 \text{ mm} \times 1189 \text{ mm}$ . For smaller sheets the longest side is progressively halved; the designations and dimensions are given in Table 7.1 and Fig. 7.1. Since the A0 size has the area of  $1 \text{ m}^2$ , paper weights are conveniently expressed in the unit ‘grams per square meter’.

Drawing sheets may be obtained from a standard roll of paper or already cut to size. Cut sheets sometimes have a border of at least 15 mm width to provide a frame and this frame may be printed with microfilm registration marks, which are triangular in shape and positioned on the border at the vertical and horizontal center lines of the sheet.

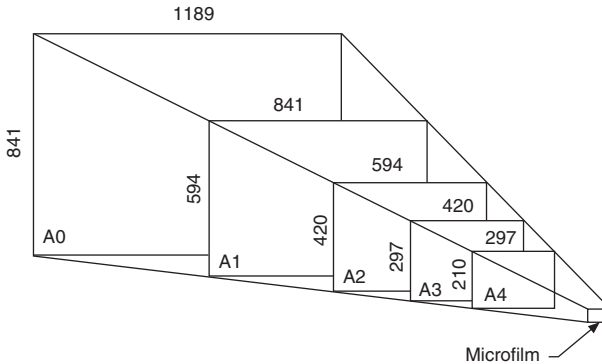
Title blocks are also generally printed in the bottom right-hand corner of cut sheets and contain items of basic information required by the drawing office or user of the drawing. Typical references are as follows:

- Name of firm;
- Drawing number;
- Component name;
- Drawing scale and units of measurement;
- Projection used (first or third angle) and/or symbol;
- Designers name and checker’s signature;
- Date of drawing and subsequent modifications;
- Cross-references with associated drawings or assemblies.

Other information will vary according to the branch and type of industry concerned but is often standardized by particular firms for their own specific purposes and convenience.

**Table 7.1** Drawing sheet sizes.

Designation	Size (mm)	Area
A0	$841 \times 1189$	$1 \text{ m}^2$
A1	$594 \times 841$	$5000 \text{ cm}^2$
A2	$420 \times 594$	$2500 \text{ cm}^2$
A3	$297 \times 420$	$1250 \text{ cm}^2$
A4	$210 \times 297$	$625 \text{ cm}^2$



**Fig. 7.1** Standard size reductions from A0 to 35 mm microfilm.

## Presentation

Drawing sheets and other documents should be presented in one of the following formats:

- (a) *Landscape* – presented to be viewed with the longest side of the sheet horizontal.
- (b) *Portrait* – presented to be viewed with the longest side of the sheet vertical.

## Types of line and their application

Two thicknesses of line are recommended for manual and CAD (computer aided design) drawings: a wide line and a narrow line in the ratio of 2:1.

Standard lead holders, inking pens for manual use, and those for CAD plotters are all available in the following mm sizes: 0.25, 0.35, 0.5, 0.7, 1.0, 1.4, and 2.0.

Line thicknesses of 0.7 and 0.35 are generally used and will give good quality, black, dense, and contrasting lines.

[Table 7.2](#) shows applications for different line types which are designed to obtain a good professional finish to a drawing. Line type designations are as referenced in ISO 128-24.

Various combinations of line thickness and type are shown for the mechanism in [Fig. 7.2](#). Circled numbers relate to the line types in [Table 7.2](#).

[Fig. 7.3](#) shows part of a cone and if the complete cone was required, for example for dimensioning purposes, then the rest would be shown by adding narrow continuous lines which intersect in a dot.

If it is necessary to show the initial outline of a part before it is bent or formed, then the initial outline can be indicated by a chain thin line which is double dashed. [Fig. 7.4](#) shows the standard applied to a metal strip.

[Fig. 7.5](#) shows the method of detailing a long strip of metal which has 60 holes in it at constant pitch. There would be no need to detail all of the component and this

**Table 7.2** Types of line.

<b>Example</b>	<b>Type</b>	<b>Description and representation</b>		<b>Application</b>
A	01.2	Continuous wide line	1234	Visible edges and outlines Crests of screw threads and limit of length of full depth thread Main representations on diagrams, maps, and flow charts Lines of cuts and sections
B	01.1	Continuous narrow line	1,234,567,891,011	Dimension, extension, and projection lines Hatching lines for cross-sections Leader and reference lines Outlines of revolved sections Imaginary lines of intersection Short center lines Diagonals indicating flat surfaces Bending lines Indication of repetitive features Root of screw threads Indication of repetitive features
C	01.1	Continuous narrow irregular line		Limits of partial views or sections provided the line is not an axis
D	02.1	Dashed narrow line		Hidden outlines and edges
E	04.1	Long-dashed dotted narrow line	12,345	Center lines Lines of symmetry Pitch circle for gears Pitch circle for holes Cutting planes (see F [04.2] for ends and changes of direction)
F	04.2	Long-dashed dotted wide line	12	Surfaces which have to meet special requirements cutting planes at ends and changes of direction (see E 04.1)

*Continued*

**Table 7.2** Types of line.—cont'd

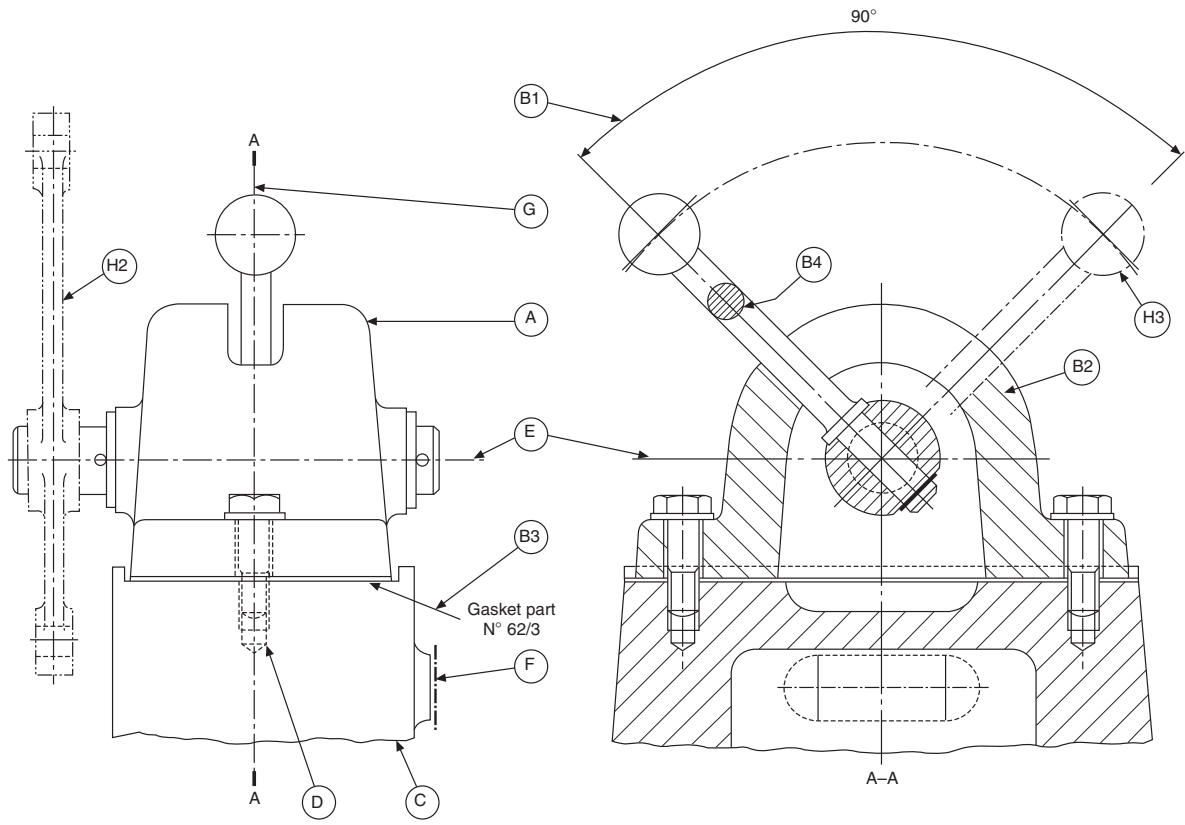
Example	Type	Description and representation		Application
G		Long-dashed dotted narrow line with wide line at ends and at changes to indicate cutting planes		Note BS EN ISO 128-24 shows a long-dashed dotted wide line for this application
H	05.1	Long-dashed double dotted narrow line	123,456,789	Outlines of adjacent parts extreme positions of movable parts Initial outlines prior to forming Outline of finished parts within blanks Projected tolerance zones Parts situated at the front of a cutting plane Framing of particular fields or areas Centroidal lines Outlines of alternative executions
J	01.1	Continuous straight narrow line with zig-zags		Limits of partial or interrupted views Suitable for CAD drawings provided the line is not an axis

illustration gives one end only. The line to show the interruption in the drawing is narrow continuous and with the zig-zag cutting line indicated by the letter J.

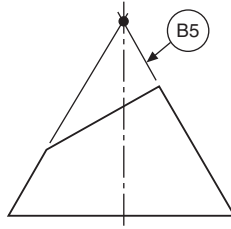
## Chain lines

Particular care should be taken with chain lines to ensure that they are neatly applied and attention is drawn to the following points:

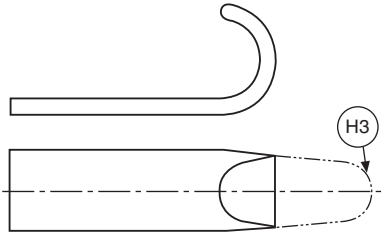
- (a) All chain lines should start and finish with a long dash.
- (b) When center points are defined, the chain lines should cross one another at solid portions of the line.



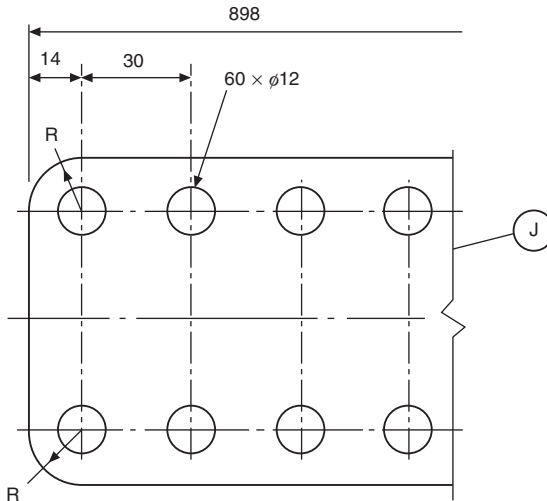
**Fig. 7.2** Example of line thickness and type.



**Fig. 7.3** Example showing imaginary lines of intersection.



**Fig. 7.4** Initial outline applications.



**Fig. 7.5** Interrupted view application.

- (c) Center lines should extend for a short distance beyond the feature unless they are required for dimensioning or other purposes.
- (d) Center lines should not extend through the spaces between views and should never terminate at another line on the drawing.
- (e) If an angle is formed by chain lines, then the long dashed should intersect and define the angle.

- (f) Arcs should meet straight lines at tangency points.
- (g) When drawing hidden detail, a dashed line should start and finish with dashes in contact with the visible lines from which they originate.
- (h) Dashed lines should also meet with dashes at corners when drawing hidden detail.

## Coinciding lines

It is inevitable that at some time when producing a drawing two or more lines of differing types will coincide. The following order of priority should be applied:

- (a) Visible outlines and edges
- (b) Cutting planes
- (c) Hidden outlines and edges
- (d) Center lines and lines of symmetry
- (e) Centroidal lines
- (f) Projection lines.

## Lettering

It has previously been mentioned that technical drawings are prepared using only two-line thicknesses and if reasonable care is taken a pleasing result can easily be obtained. Drawings invariably need dimensions and notes and if these are added in a careless and haphazard manner, then a very poor overall impression might be given. Remember that technical drawings are the main line of communication between the originator and the user. Between a consultant and his client, the sales manager and his customer, and the designer and the manufacturer, a neat well-executed technical drawing helps to establish confidence. The following notes draw attention to small matters of detail which we hope will assist the designer's technique of lettering.

- (a) The spacing round each character is important to ensure that 'filling in' will not occur during reproduction.
- (b) Lettering should not be underlined since this impairs legibility.
- (c) On parts lists or where information is tabulated, the letters or numerals should not be allowed to touch the spacing lines.
- (d) All drawing notes and dimensions should remain legible on reduced size copies and on the screens of microfilm viewers.
- (e) Capital letters are preferred to lower case letters since they are easier to read on reduced size copies of drawings. Lower case letters are generally used only where they are parts of standard symbols, codes, or abbreviations.

## Minimum character height for capital letters and numerals

Table 7.3 gives the minimum recommended character heights for different sizes of drawing sheet and it is stressed that these are *minimum* sizes. If lower case letters

**Table 7.3** Minimum character heights for drawing sheets.

Application	Drawing sheet size	Minimum character height (mm)
Drawing numbers	A0, A1, A2, and A3	7
	A4	5
Dimensions and notes	A0	3.5
	A1, A2, A3, and A4	2.5

are used then they should be proportioned so that the body height will be approximately 0.6 times the height of a capital letter.

The stroke thickness should be approximately 0.1 times the character height and the clear space between characters should be about 0.7 mm for 2.5 mm capitals and other sizes in proportion.

The spaces between lines of lettering should be consistent and preferably not less than half the character height. In the case of titles, this spacing may have to be reduced.

All notes should be placed so that they may be read from the same direction as the format of the drawing but there are cases, for example when a long vertical object is presented, where it may be necessary to turn the drawing sheet through 90° in the clockwise direction, in effect, to position the note which is then read from the right hand side of the drawing sheet.

The shape and form of an acceptable range of letters and numbers is illustrated in Fig. 7.6.

Open styles are often used on drawings which are to be microfilmed, as increased clarity is obtainable on small reproductions.

- (A) ABCDEFGHIJKLMNOPQRSTUVWXYZ  
 abcdefghijklmnopqrstuvwxyz  
 1234567890
- (B) *ABCDEFGHIJKLMN**OPQRSTUVWXYZ*  
*abcdefghijklmnopqr**stuvwxyz*  
*1234567890*
- (C) ABCDEFGHIJKLMNOPQRSTUVWXYZ  
 a**bc**defghijklmnopqrstuvwxyz  
 1234567890
- (D) ABCDEFGHIJKLMNOPQRSTUVWXYZ  
 a**bc**defghijklmnopqrstuvwxyz  
 1234567890
- (E) 1234567890
- (F) 12334567890

**Fig. 7.6** Shape and form of characters.

## Drawing modifications

Revisions and modifications are regularly made to update a product, due, for example, to changes in materials, individual components, manufacturing techniques, operating experience, and other causes outside the designer's control.

When a drawing is modified, its content changes and it is vital that a note is given on the drawing or on a drawing change record sheet, describing the reason for change, the actual change (is/was i.e. dim 50 was 45) and the date that modifications were made. Today, with the ability to electronically copy, change and compare the two drawings, a record of change is often overlooked. This can be present a problem to the manufacturing department as they will have to carry out the comparison to see what re-work is require and there is a risk that a change could be missed. Updated drawings are then reissued to interested parties. Current users must all read from a current copy. Near the title block, on a drawing will be placed a box giving the date and Issue No., i.e. XXX A. These changes would usually be of a minimal nature.

If a component drawing is substantially altered, it can be completely redrawn and given an entirely new number.

## Care and storage of hard copy original drawings

Valuable drawings need satisfactory handling and storage facilities in order to preserve them in first class condition. Drawings may be used and re-used many times and minimum wear and tear is essential if good reproductions and microfilms are to be obtained over a long period of time. The following simple rules will assist in keeping drawings in 'mint' condition.

1. Never fold drawings.
2. Do not roll drawings tightly since they may not lie flat during microfilming.
3. Drawings should be stored under conditions of normal heat and humidity, at about 21 °C and 40–60% relative humidity.

# Three-dimensional illustrations using isometric and oblique projection

## Isometric projection

Fig. 8.1 shows three views of a cube in orthographic projection; the phantom line indicates the original position of the cube, and the full line indicates the position after rotation about the diagonal AB. The cube has been rotated so that the angle of  $45^\circ$  between side AC and diagonal AB now appears to be  $30^\circ$  in the front elevation,  $C_1$  having been rotated to position C. It can clearly be seen in the end view that to obtain this result the angle of rotation is greater than  $30^\circ$ . Also, note that, although DF in the front elevation appears to be vertical, a cross check with the end elevation will confirm that the line slopes, and that point F lies to the rear of point D. However, the front elevation now shows a three-dimensional view, and when taken in isolation it is known as an *isometric projection*.

This type of view is commonly used in pictorial presentations, for example in car and motor-cycle service manuals and model kits, where an assembly has been ‘exploded’ to indicate the correct order and position of the component parts.

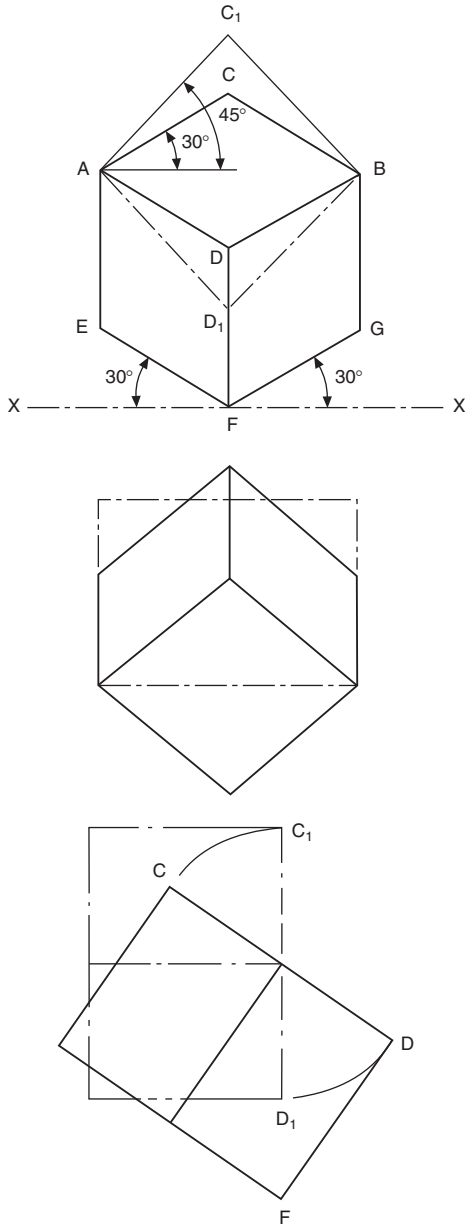
It will be noted that, in the isometric cube, line  $AC_1$  is drawn as line AC, and the length of the line is reduced. Fig. 8.2 shows an isometric scale which in principle is obtained from lines at  $45^\circ$  and  $30^\circ$  to a horizontal axis. The  $45^\circ$  line XY is calibrated in millimetres commencing from point X, and the dimensions are projected vertically on to the line XZ. By similar triangles, all dimensions are reduced by the same amount, and isometric lengths can be measured from point X when required. The reduction in length is in the ratio

$$\frac{\text{isometric length}}{\text{true length}} = \frac{\cos 45^\circ}{\cos 30^\circ} = 0.8165$$

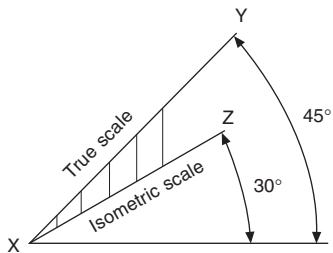
Now, to reduce the length of each line by the use of an isometric scale is an interesting academic exercise, but commercially an isometric projection would be drawn using the true dimensions and would then be enlarged or reduced to the size required.

Note that, in the isometric projection, lines AE and DB are equal in length to line AD; hence an equal reduction in length takes place along the apparent vertical and the two axes at  $30^\circ$  to the horizontal. Note also that the length of the diagonal AB does not change from orthographic to isometric, but that of diagonal CD clearly does. When setting out an isometric projection, therefore, measurements must be made only along the isometric axes EF, DF, and GF.

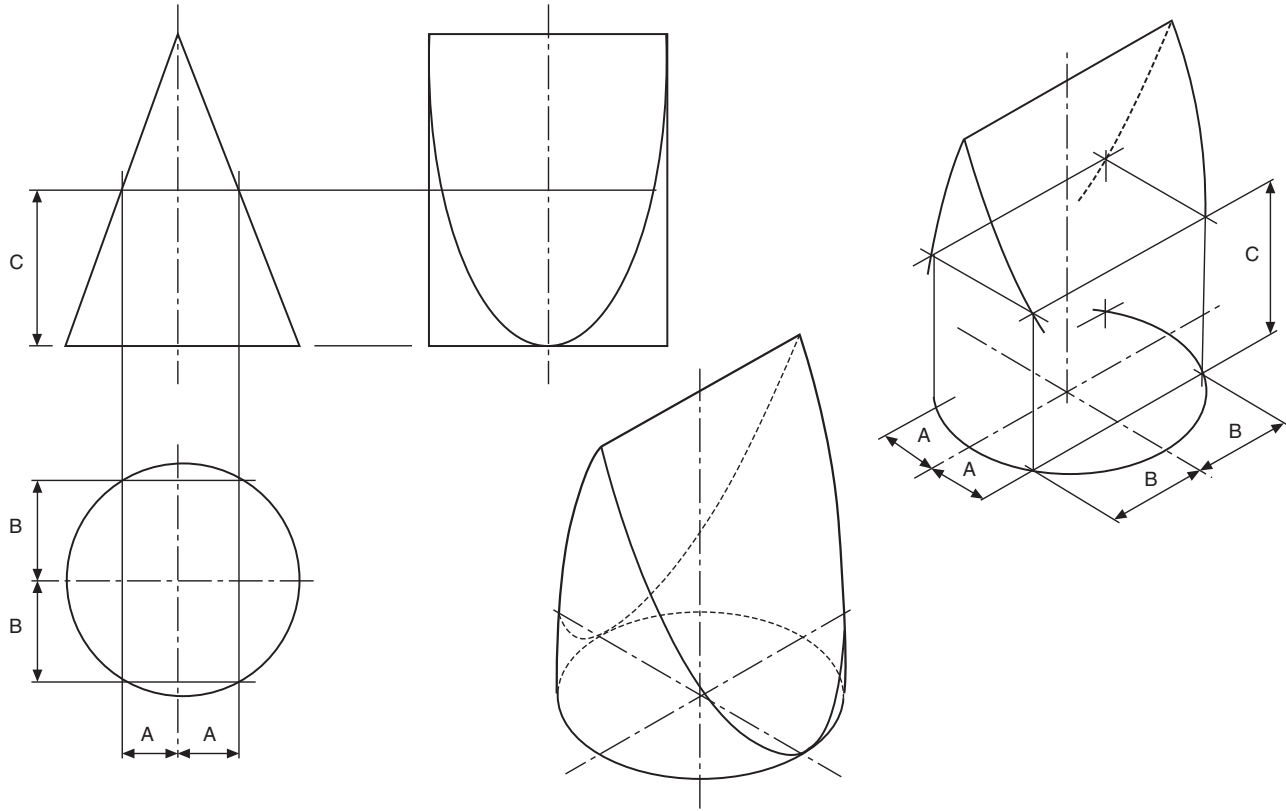
Fig. 8.3 shows a wedge which has been produced from a solid cylinder, and dimensions A, B, and C indicate typical measurements to be taken along the principal axes



**Fig. 8.1** Cube in orthographic projection.



**Fig. 8.2** Isometric scale.



**Fig. 8.3** Construction principles for points in space, with complete solution.

when setting out the isometric projection. Any curve can be produced by plotting a succession of points in space after taking ordinates from the  $X$ ,  $Y$ , and  $Z$  axes.

Fig. 8.4A shows a cross-section through an extruded alloy bar: the views (b), (c), and (d) give alternative isometric presentations drawn in the three principal planes of projection. In every case, the lengths of ordinates  $OP$ ,  $OQ$ ,  $P1$ , and  $Q2$ , etc. are the same, but are positioned either vertically or inclined at  $30^\circ$  to the horizontal.

Fig. 8.5 shows an approximate method for the construction of isometric circles in each of the three major planes. Note the position of the points of intersection of radii  $RA$  and  $RB$ .

The construction shown in Fig. 8.5 can be used partly for producing corner radii.

Fig. 8.6 shows a small block with radiused corners together with isometric projection

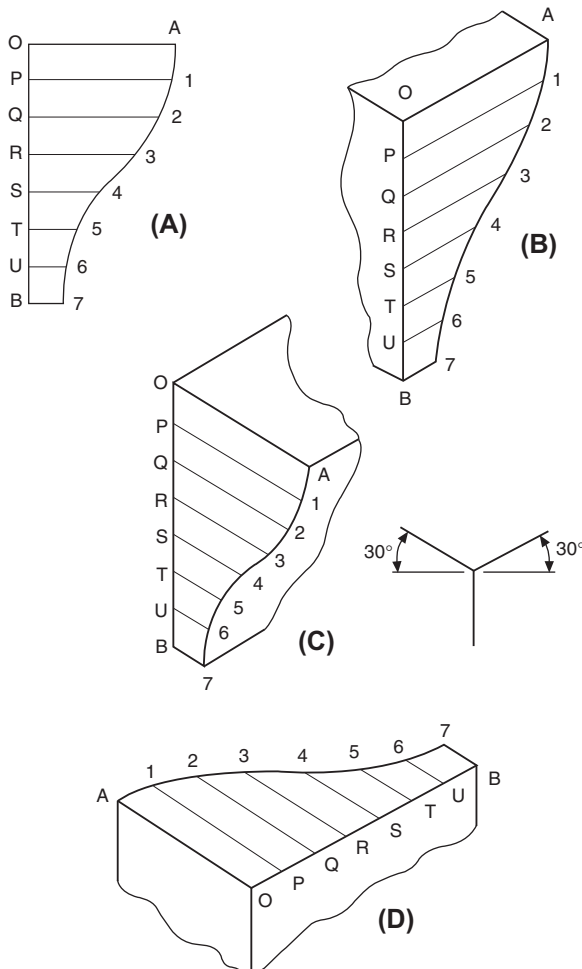
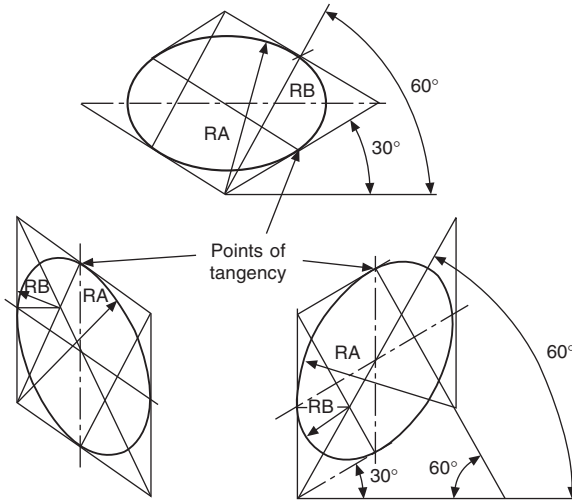


Fig. 8.4 Views (B), (C) and (D) are isometric projections of the section in view (A).



**Fig. 8.5** Approximate method for construction of isometric circles.

which emphasizes the construction to find the centers for the corner radii; this should be the first part of the drawing to be attempted. The thickness of the block is obtained from projecting back these radii a distance equal to the block thickness and at  $30^\circ$ . Line in those parts of the corners visible behind the front face, and complete the pictorial view by adding the connecting straight lines for the outside of the profile.

In the approximate construction shown, a small inaccuracy occurs along the major axis of the ellipse, and Fig. 8.7 shows the extent of the error in conjunction with a plotted circle. In the vast majority of applications where complete but small circles are used, for example spindles, pins, parts of nuts, bolts, and fixing holes, this error is of little importance and can be neglected.

## Oblique projection

Fig. 8.8 shows part of a plain bearing in orthographic projection, and Figs. 8.9 and 8.10 show alternative pictorial projections.

It will be noted in Figs. 8.9 and 8.10 that the thickness of the bearing has been shown by projecting lines at  $45^\circ$  back from a front elevation of the bearing. Now, Fig. 8.10 conveys the impression that the bearing is thicker than the true plan suggests, and therefore in Fig. 8.9 the thickness has been reduced to one-half of the actual size. Fig. 8.9 is known as an *oblique projection*, and objects which have curves in them are easiest to draw if they are turned, if possible, so that the curves are presented in the front elevation. If this proves impossible or undesirable, then Fig. 8.11 shows part of the ellipse which results from projecting half sizes back along the lines inclined at  $45^\circ$ .

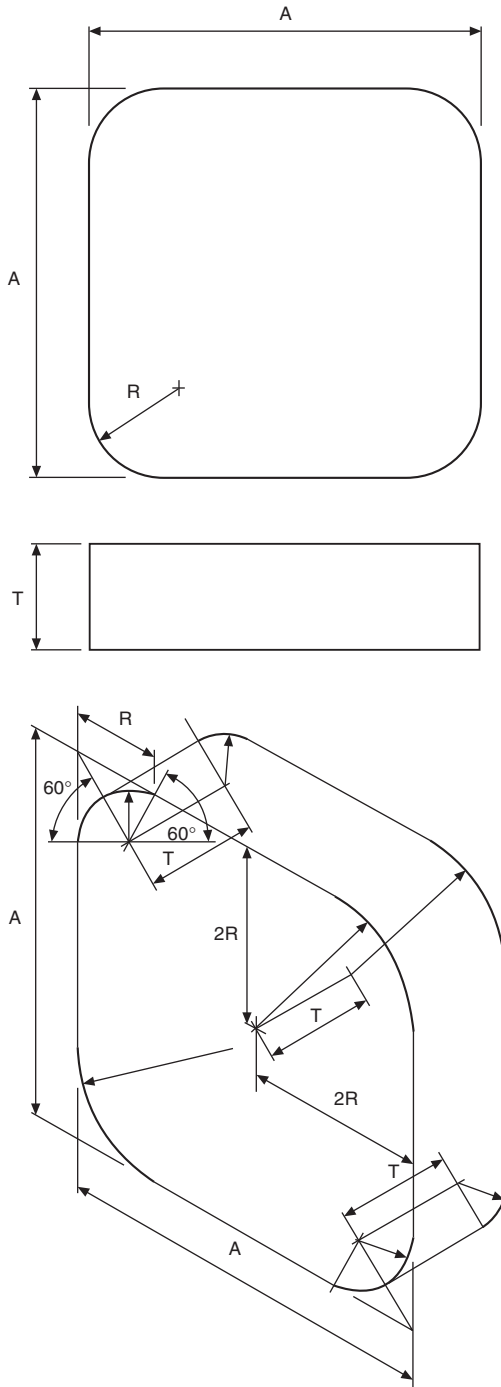
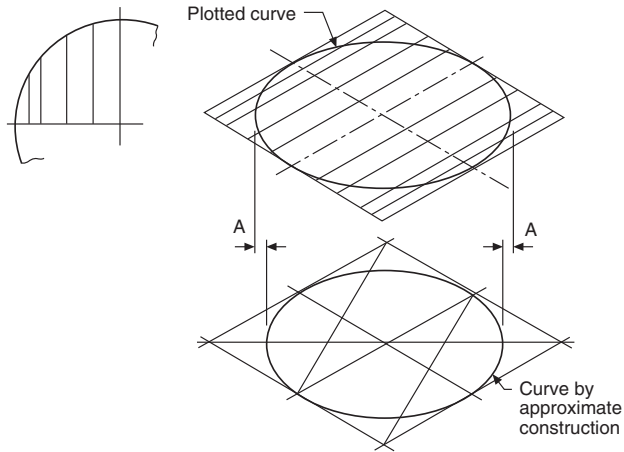
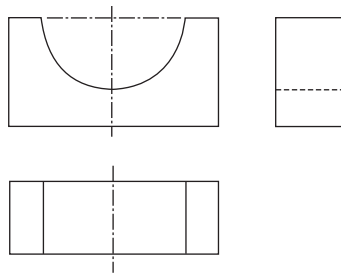


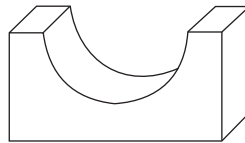
Fig. 8.6 Isometric constructions for corner radii.



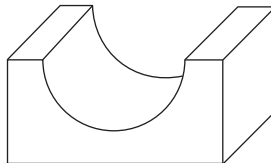
**Fig. 8.7** Relationship between plotted points and constructed isometric circles.



**Fig. 8.8** Bearing block in orthographic projection.

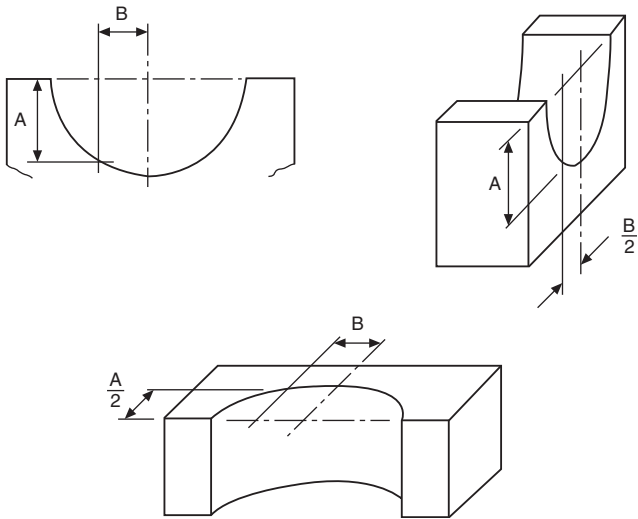


**Fig. 8.9** Pictorial representation of Fig 8.8.

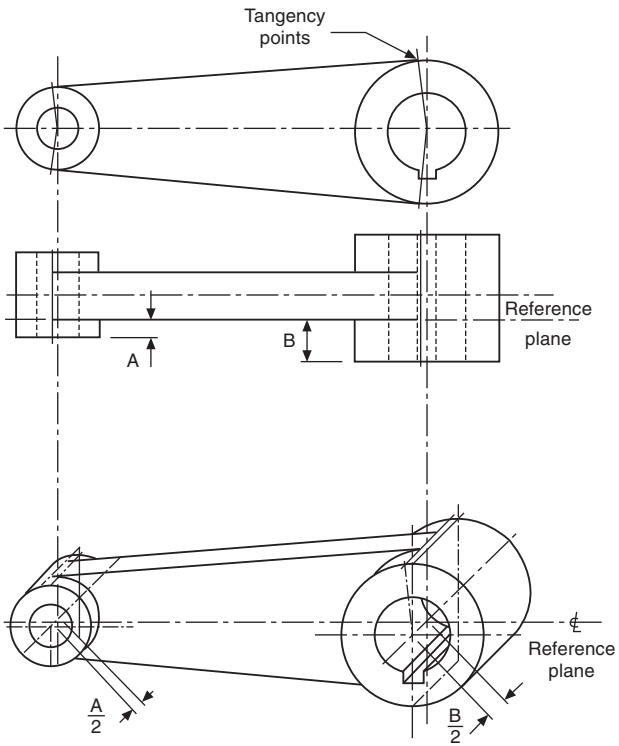


**Fig. 8.10** Alternative pictorial representation of Fig 8.8.

A small die-cast lever is shown in Fig 8.12, to illustrate the use of a reference plane. Since the bosses are of different thicknesses, a reference plane has been taken along the side of the web; and from this reference plane, measurements are taken forward to the boss faces and backwards to the opposite sides. Note that the points of tangency are marked to position the slope of the web accurately.



**Fig. 8.11** Oblique projection.



**Fig. 8.12** Projection using a reference plane.

With oblique and isometric projections, no allowance is made for perspective, and this tends to give a slightly unrealistic result, since parallel lines moving back from the plane of the paper do not converge.

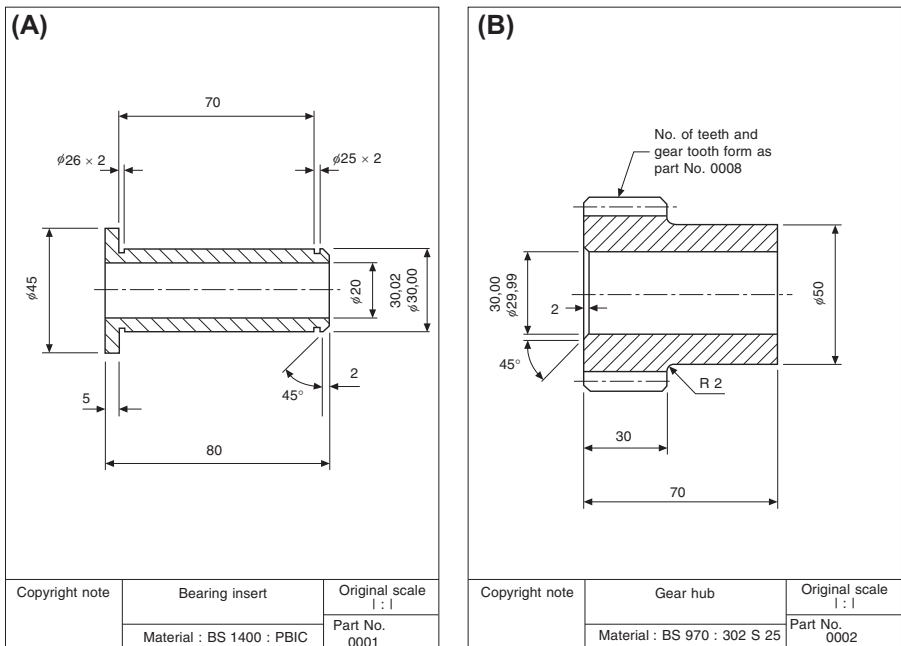
For further information regarding pictorial representations, reference can be made to BS EN ISO 5456-3. The Standard contains details of dimetric, trimetric, cavalier, cabinet, planometric, and perspective projections.

# Drawing layouts and simplified methods

## Single-part drawing

A single-part drawing should supply the complete detailed information to enable a component to be manufactured without reference to other sources. It should completely define shape or form and size, and should contain a specification. The number of views required depends on the degree of complexity of the component. The drawing must be fully dimensioned, including tolerances where necessary, to show all sizes and locations of the various features. The specification for the part includes information relating to the material used and possible heat-treatment required, and notes regarding finish. The finish may apply to particular surfaces only, and may be obtained by using special machining operations or, for example, by plating, painting, or enamelling. Fig. 9.1 shows typical single-part drawings.

An alternative to a single-part drawing is to collect several small details relating to the same assembly and group them together on the same drawing sheet. In practice, grouping in this manner may be satisfactory provided all the parts are made in the



**Fig. 9.1** (A) Bearing insert. (B) Gear hub. (C) Retaining ring.

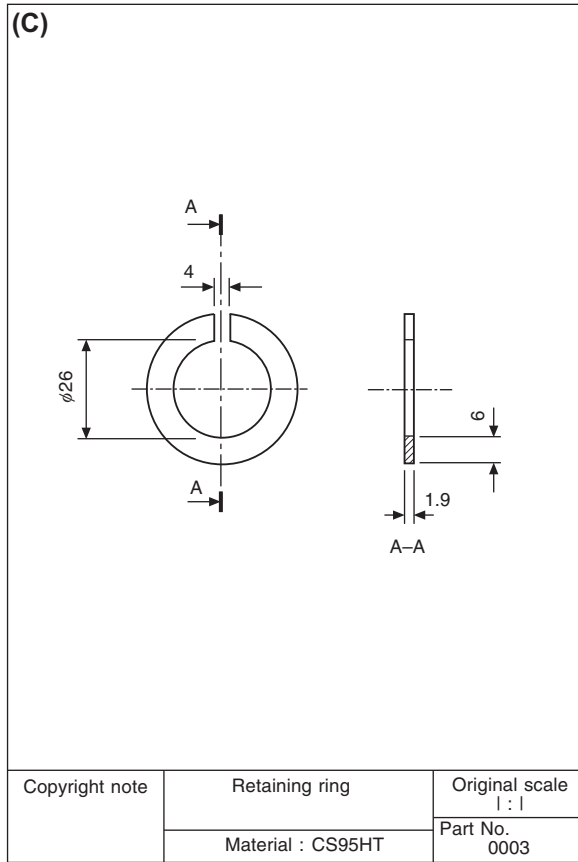


Fig. 9.1 cont'd.

same department, but it can be inconvenient where, for example, pressed parts are drawn with turned components or sheet-metal fabrications.

More than one drawing may also be made for the same component. Consider a sand-cast bracket. Before the bracket is machined, it needs to be cast; and before casting, a pattern needs to be produced by a patternmaker. It may therefore be desirable to produce a drawing for the patternmaker which includes the various machining allowances, and then produce a separate drawing for the benefit of the machinist which shows only dimensions relating to the surfaces to be machined and the size of the finished part. The two drawings would each have only parts of the specification which suited one particular manufacturing process (see also Fig. 16.34 and 16.35).

## Collective single-part drawings

Fig. 9.2 shows a typical collective single-part drawing for a rivet. The drawing covers 20 rivets similar in every respect except length; in the example given, the part number for a 30 mm rivet is S123/13. This type of drawing can also be used where, for example, two dimensions on a component (which can be referenced on the drawing as *A* and *B*) are variable, all other dimensions being standard. For a particular application, the designer would insert the appropriate value of dimensions *A* and *B* in a table, and then add a new suffix to the part number. This type of drawing can generally be used for basically similar parts.

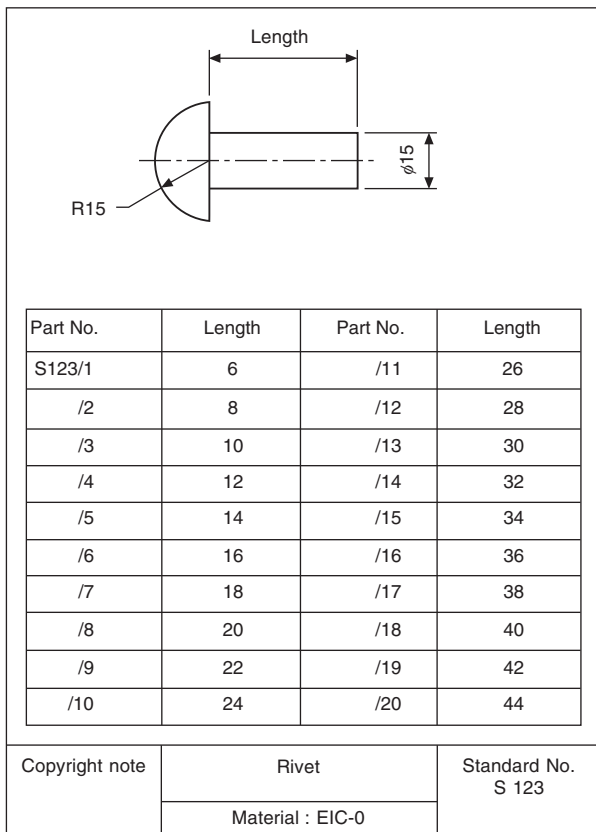


Fig. 9.2 Collective single-part drawing of a rivet.

## Assembly drawings

Machines and mechanisms consist of numerous parts, and a drawing which shows the complete product with all its components in their correct physical relationship is known as an assembly drawing. A drawing which gives a small part of the whole assembly is known as a sub-assembly drawing. A sub-assembly may in fact be a complete unit in itself; for example, a drawing of a clutch could be considered as a sub-assembly of a drawing showing a complete automobile engine. The amount of information given on an assembly drawing will vary considerably with the product and its size and complexity.

If the assembly is relatively small, information which might be given includes a parts list. The parts list, as the name suggests, lists the components, which are numbered. Numbers in ‘balloons’ with leader lines indicate the position of the component on the drawing (see Fig. 9.3). The parts list will also contain information regarding the quantity required of each component for the assembly, its individual

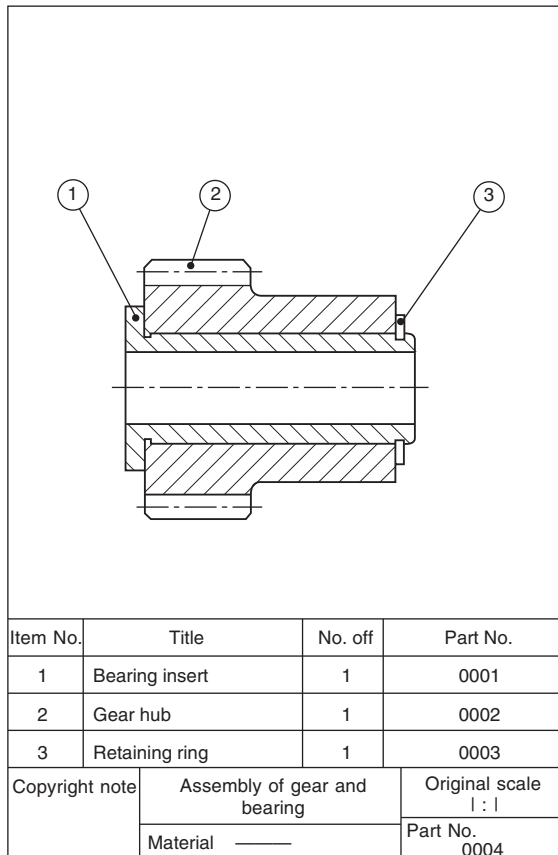


Fig. 9.3 Assembly drawing of gear and bearing.

single-part drawing number, and possibly its material. Parts lists are not standard items, and their contents vary from one drawing office to another.

The assembly drawing may also give other information, including overall dimensions of size, details of bolt sizes and centers where fixings are necessary, weights required for shipping purposes, operating details and instructions, and also, perhaps, some data regarding the design characteristics.

### Collective assembly drawing

This type of drawing is used where a range of products which are similar in appearance but differing in size are manufactured and assembled. Fig. 9.4 shows a nut-and-bolt fastening used to secure plates of different combined thickness; the nut is standard, but the bolts are of different lengths. The accompanying table is used to relate the various assemblies with different part numbers.

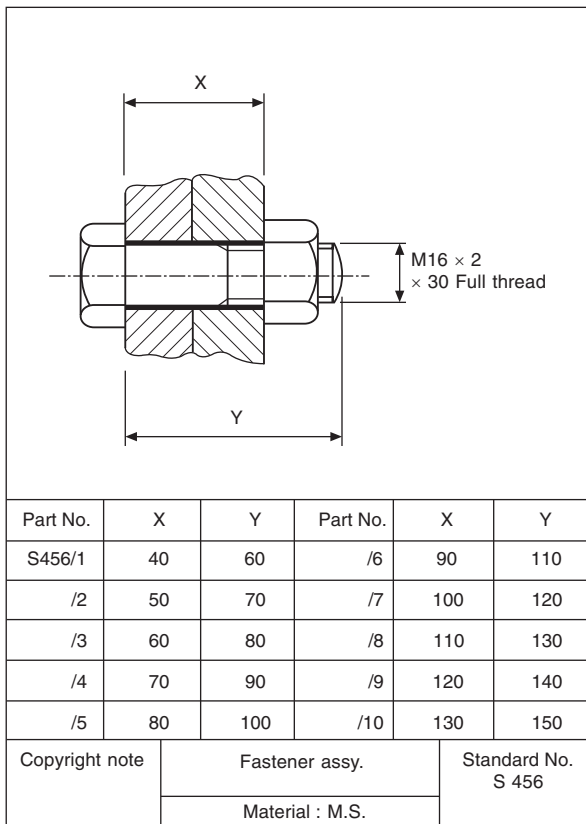


Fig. 9.4 Typical collective assembly drawing of a nut with bolts of various lengths.



## Exploded assembly drawings

Fig. 9.6 shows a typical exploded assembly drawing; these drawings are prepared to assist in the correct understanding of the various component positions in an assembly. Generally a pictorial type of projection is used, so that each part will be shown in three dimensions. Exploded views are invaluable when undertaking servicing and

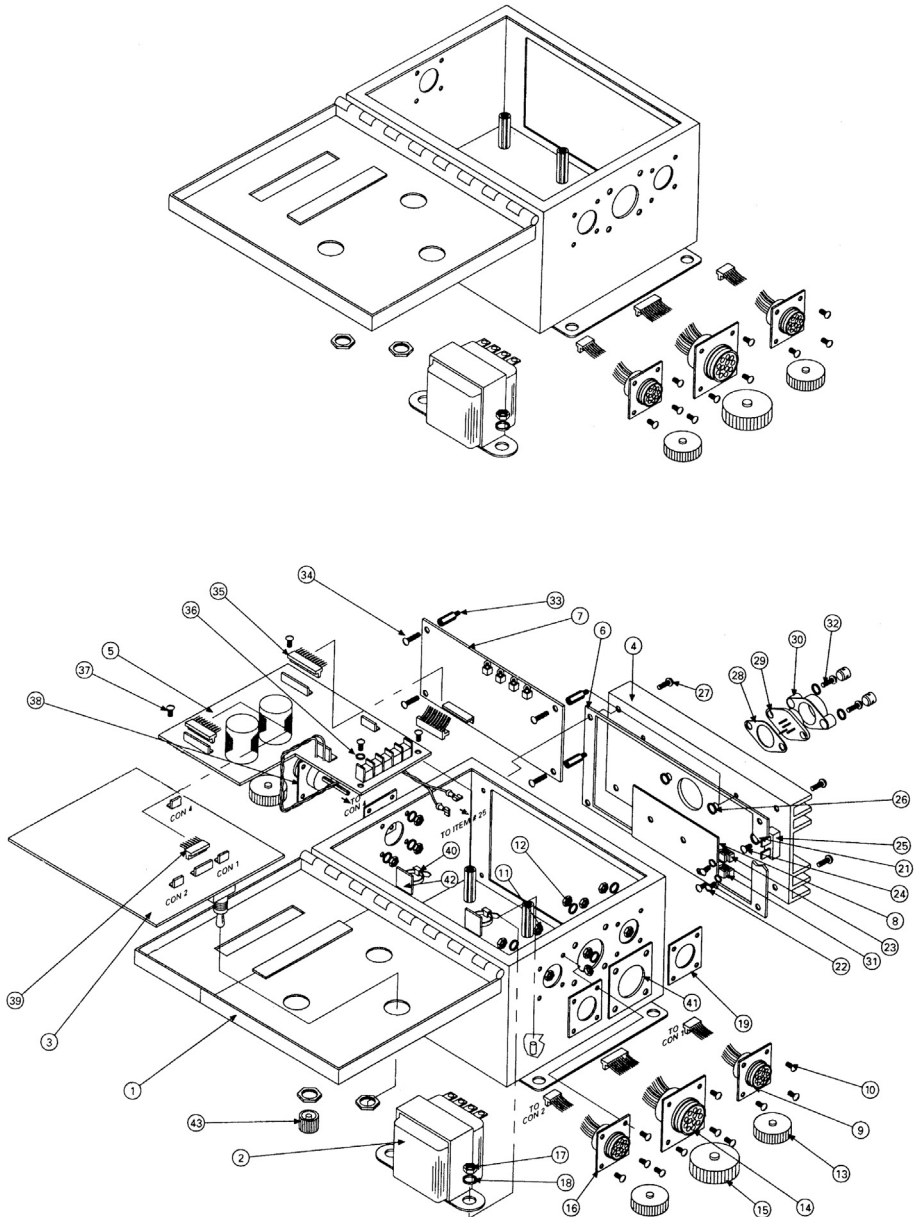


Fig. 9.6 Exploded assembly drawing.

maintenance work on all forms of plant and appliances. Car manuals and do-it-yourself assembly kits use such drawings, and these are easily understood. As well as an aid to construction, an exploded assembly drawing suitably numbered can also be of assistance in the ordering of spare parts; components are more easily recognizable in a pictorial projection, especially by people without training in the reading of technical drawings.

## Simplified drawings

Simplified draughting conventions have been devised to reduce the time spent drawing and detailing symmetrical components and repeated parts. Fig. 9.7 shows a gasket which is symmetrical about the horizontal center line. A detail drawing indicating the line of symmetry and half of the gasket is shown in Fig. 9.8, and this is sufficiently clear for the part to be manufactured.

If both halves are similar except for a small detail, then the half which contains the exception is shown with an explanatory note to that effect, and a typical example is illustrated in Fig. 9.9.

A joint-ring is shown in Fig. 9.10, which is symmetrical about two axes of symmetry. Both axes are shown in detail, and a quarter view of the joint-ring is sufficient for the part to be made.

The practice referred to above is not restricted to flat thin components, and Fig. 9.11 gives a typical detail of a straight lever with a central pivot in part section. Half the lever is shown, since the component is symmetrical, and a partial view is added and drawn to an enlarged scale to clarify the shape of the boss and leave an adequate space for dimensioning.

Repeated information also need not be drawn in full; for example, to detail the peg-board in Fig. 9.12 all that is required is to draw one hole, quoting its size and fixing the centers of all the others.

Similarly Fig. 9.13 shows a gauze filter. Rather than draw the gauze over the complete surface area, only a small portion is sufficient to indicate the type of pattern required.

Knurled screws are shown in Fig. 9.14 to illustrate the accepted conventions for straight and diamond knurling.

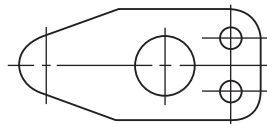
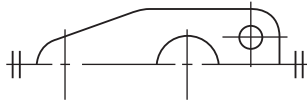
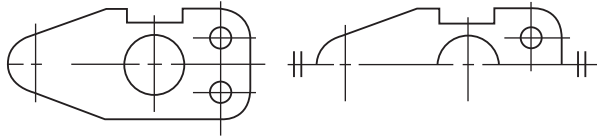


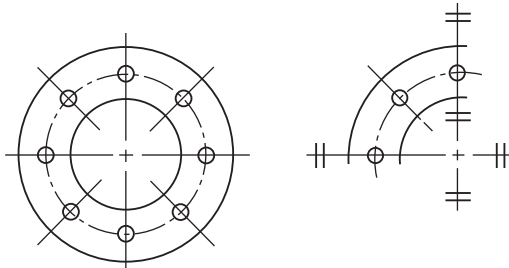
Fig. 9.7 Gasket plan view.



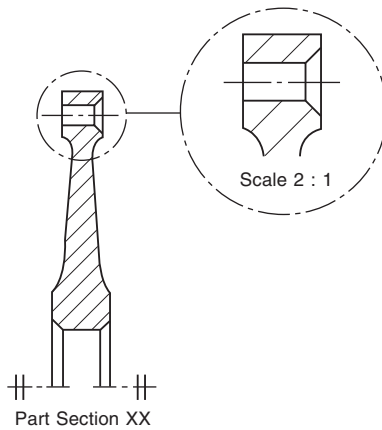
**Fig. 9.8** Gasket, half detailed along line of symmetry.



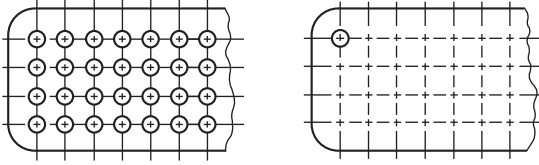
**Fig. 9.9** When dimensioning add drawing note 'slot on one side only'.



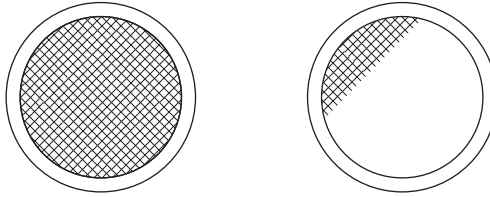
**Fig. 9.10** Joint ring, quarter view along lines of symmetry.



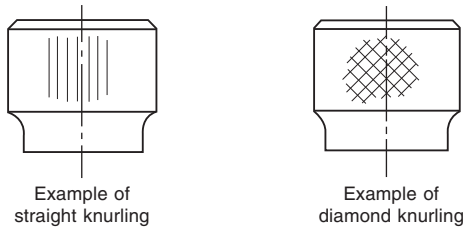
**Fig. 9.11** Part of a lever detail drawing symmetrical about the horizontal axis.



**Fig. 9.12** Simplified indication of a pattern of holes.



**Fig. 9.13** Partial detailing of gauze.



**Fig. 9.14** Detailing of straight and diamond knurling.

## Machine drawings

The designer must be able to appreciate the significance of every line on a machine drawing. They must also understand the basic terminology and vocabulary used in conjunction with machine drawings.

Machine drawings of components can involve any of the geometrical principles and constructions described in this book and in addition the accepted drawing Standards covered by BS 8888.

**Fig. 9.15** illustrates many features found on machine drawings and the notes which follow give additional explanations and revision comments.

1. *Angular dimension* – Note that the circular dimension line is taken from the intersection of the center lines of the features.
2. *Arrowheads* – The point of an arrowhead should touch the projection line or surface; it should be neat and easily readable and normally not less than 3 mm in length.

3. *Auxiliary dimension* – A dimension given for information purposes but not used in the actual manufacturing process.
4. *Boss* – A projection, which is usually circular in cross-section, and often found on castings and forgings. A shaft boss can provide extra bearing support, for example, or a boss could be used on a thin cast surface to increase its thickness in order to accommodate a screw thread.
5. *Center line* – Long-dashed dotted narrow line which is used to indicate the axes of holes, components, and circular parts.
6. *Long-dashed dotted wide line* – This is used to indicate surfaces which are required to meet special specifications and which differ from the remainder of the component.
7. *Chamfer* – A chamfer is machined to remove a sharp edge. The angle is generally  $45^\circ$ . Often referred to as a beveled edge.
8. *Circlip groove* – A groove to accommodate a circlip. A circlip may be manufactured from spring steel wire, sheet, or plate which is hardened and tempered and when applied in an assembly provides an inward or outward force to locate a component within a bore or housing.
9. *Clearance hole* – A term used in an assembly to describe a particular hole which is just a little larger and will clear the bolt or stud which passes through.
10. *Counterbore* – A counterbored hole may be used to house a nut or bolt head so that it does not project above a surface. It is machined so that the bottom surface of the larger hole is square to the hole axis.
11. *Countersink* – A hole which is recessed conically to accommodate the head of a rivet or screw so that the head will lie at the same level as the surrounding surface.
12. *Section plane* or *cutting plane* – These are alternative terms used to define the positions of planes from which sectional elevations and plans are projected.
13. *Dimension line* – This is a narrow continuous line which is placed outside the outline of the object, if possible. The arrowheads touch the projection lines. The dimension does not touch the line but is placed centrally above it.
14. *Enlarged view* – Where detail is very small or insufficient space exists for dimensions or notes then a partial view may be drawn with an increased size scale.
15. *Round* – This term is often used to describe an external radius.
16. *Fillet* – This is the term given to the radii on internal corners. Often found on castings, where its function is to prevent the formation of stress cracks, which can originate from sharp corners. Where three surfaces meet on a casting the fillet radii will be spherical.
17. *Flange* – This is a term to describe a projecting rim or an edge which is used for stiffening or for fixing. The example here is drilled for countersunk screws.
18. *Hatching* – Note that cross hatching of the component at the section plane is performed with narrow continuous lines at  $45^\circ$ . Spacing between the hatching lines varies with the size of the component but should not be less than 4 mm.
19. *Hidden detail* – Indicated by a narrow dashed line. Dashes of 3 mm and spaces of 2 mm are of reasonable proportion.
20. *Knurl* – A surface finish with a square or diamond pattern. Can be used in a decorative manner or to improve grip.

21. *Leader line* – Leaders are used to indicate where dimensions or notes apply and are drawn as narrow continuous lines terminating in arrowheads or dots. An arrowhead should always terminate on a line; dots should be within the outline of the object.
22. *Local section* – A local section may be drawn if a complete section or a half section is inconvenient. The local break around the section is a continuous narrow irregular line.
23. *Machining center* – An accurately drilled hole with a good finish at each end of the component which enables the work to be located during a machining operation on a lathe.
24. *Machining symbol* – If it is desired to indicate that a particular surface is to be machined, without further defining the actual machining process or the surface finish, a symbol is added normal to the line representing the surface. The included angle of the symbol is approximately  $60^\circ$ . A general note may be added to a drawing where all surfaces are to be machined as follows:
25. *Surface finish* – If a surface is to be machined and a particular quality surface texture is desired then a standard machining symbol is added to the drawing with a number which gives the maximum permissible roughness expressed numerically in micrometers.
26. *Surface finish* – If maximum and minimum degrees of roughness are required then both figures are added to the machining symbol.
27. *Pitch circle diameter* – A circle which passes through the centers of a series of holes. The circle is drawn with a long dashed dotted narrow line.
28. *Recess* – A hollow feature which is used to reduce the overall weight of the component. A recess can also be used to receive a mating part.
29. *Slot* – An alternative term for a slit, groove, channel, or aperture.
30. *Spigot* – A circular projection which is machined to provide an accurate location between assembled components.
31. *Splined shaft* – A rotating member which can transmit a torque to a mating component. The mating component may move axially along the splines which are similar in appearance to keyways around the spindle surface.
32. *Square* – Diagonal lines are drawn to indicate the flat surface of the square and differentiate between a circular and a square section shaft. The same convention is used to show spanner flats on a shaft.
33. *Taper* – A term used in connection with a slope or incline. Rate of taper can also define a conical form.
34. *Taper symbol* – The taper symbol is shown in a rectangular box indicating it is a Theoretical Exact Dimension (TED) (see Chapter 22). Dimensional information relating to the rate of taper on the diameter is also included. Normally there should be a geometrical tolerance associated with the TED such as Profile of a Surface.
35. *External thread* – An alternative term used for a male thread. The illustration here shows the thread convention.
36. *Internal thread* – An alternative term for a female thread. The illustration here shows the convention for a female tapped hole.
37. *Undercut* – A circular groove at the bottom of a thread which permits assembly without interference from a rounded corner. Note in the illustration that a member can be screwed along the M20 thread right up to the tapered portion.
38. *Woodruff key* – A key shaped from a circular disc which fits into a circular keyway in a tapered shaft. The key can turn in the circular recess to accommodate any taper in the mating hub.
39. *Key* – A small block of metal, square or rectangular in cross-section, which fits between a shaft and a hub and prevents circumferential movement.
40. *Keyway* – A slot cut in a shaft or hub to accommodate a key.

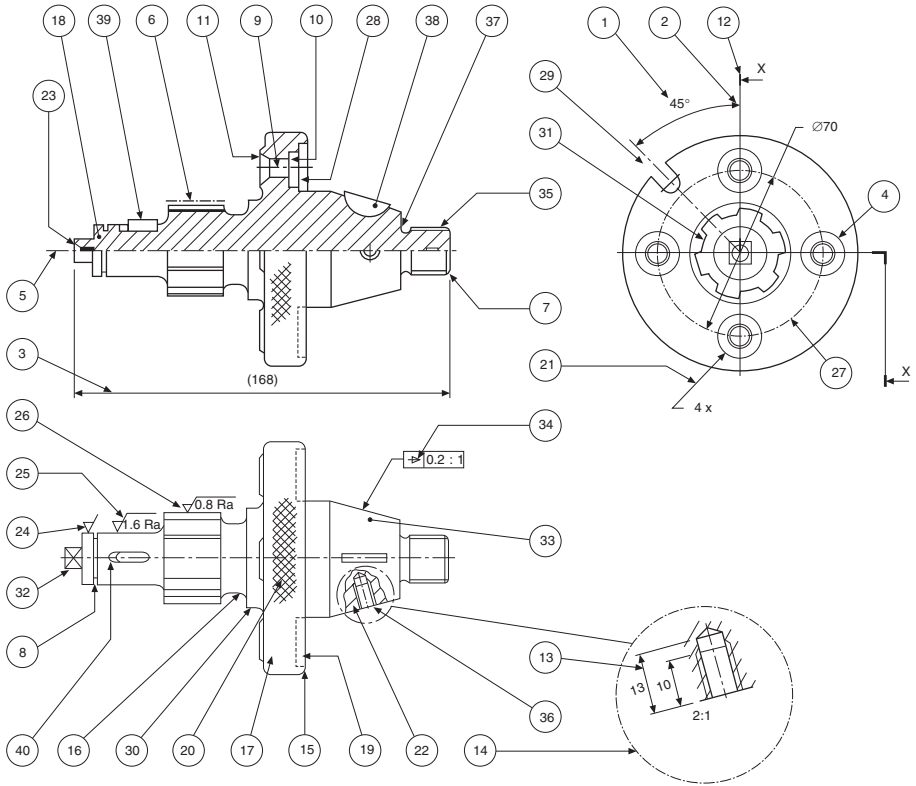


Fig. 9.15 Features found on a machining drawing.

## Drawing scales

Small objects are sometimes drawn larger than actual size, while large components and assemblies are of necessity drawn to a reduced size. A drawing should always state the scale used. The scale on a full-size drawing will be quoted as ‘ORIGINAL SCALE 1:1’.

Drawings themselves should not be scaled when in use for manufacturing purposes, and warnings against the practice are often quoted on standard drawing sheets, e.g. ‘DO NOT SCALE’ and ‘IF IN DOUBT, ASK’. A drawing must be adequately dimensioned, or referenced sufficiently so that all sizes required are obtainable.

The recommended multipliers for scale drawings are 2, 5, and 10.

- 1:1 denotes a drawing drawn full-size.
- 2:1 denotes a drawing drawn twice full-size.
- 5:1 denotes a drawing drawn five times full size.

Other common scales are 10:1, 20:1, 50:1, 100:1, 200:1, 500:1, and 1000:1.

It should be pointed out that a scale drawing can be deceiving; a component drawn twice full-size will cover four times the area of drawing paper as the same component drawn full-size, and its actual size may be difficult to visualize. To assist in appreciation, it is a common practice to add a pictorial view drawn full-size, provided that the drawing itself is intended to be reproduced to the same scale and not reproduced and reduced by microfilming.

The recommended divisors for scale drawings are also 2, 5, and 10.

1:1 denotes a drawing drawn full-size.

1:2 denotes a drawing drawn half full-size.

1:5 denotes a drawing drawn a fifth full-size.

Other common scales used are 1:10, 1:20, 1:50, 1:100, 1:200, 1:500, and 1:1000.

The designer will select a suitable scale to use on a standard drawing sheet and this will depend on the size of the object to be drawn. Remember that the drawing must clearly show necessary information and detail. It may be beneficial to make a local enlargement of a small area and an example is given in [Fig. 9.15](#).

## Scale used in geometric construction

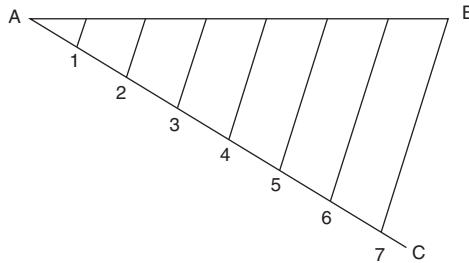
### *Division of lines*

[Fig. 9.16](#) shows the method of dividing a given line AB, 89 mm long, into a number of parts (say seven).

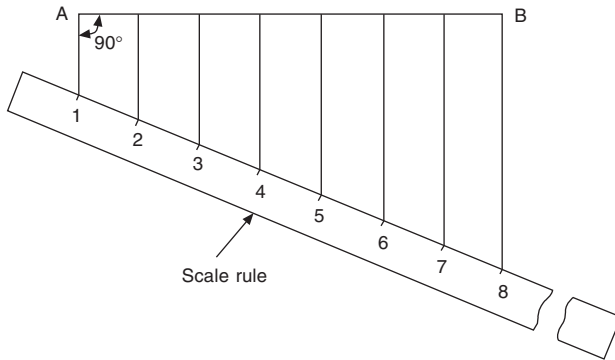
Draw line AC, and measure seven equal divisions. Draw line B7, and with the tee-square and set-square draw lines parallel to line B7 through points 1 to 6, to give the required divisions on AB.

[Fig. 9.17](#) shows an alternative method.

1. Draw vertical lines from A and B.
2. Place the scale rule across the vertical lines so that seven equal divisions are obtained and marked.
3. Draw vertical lines up from points 2 to 7 to intersect AB.



**Fig. 9.16** Geometric construction scale.



**Fig. 9.17** Alternative geometric construction scale

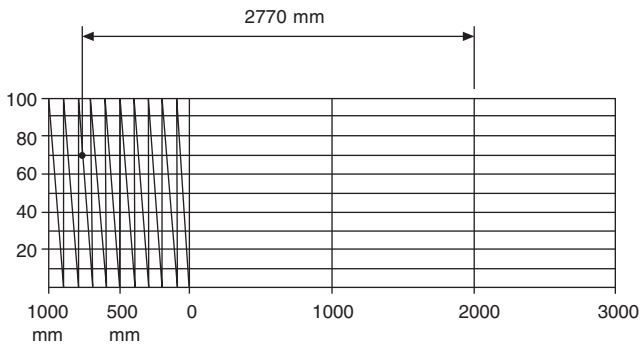
**Diagonal scales**

Fig. 9.18 shows the method of drawing a diagonal scale of 40–1000 mm which can be read by 10–4000 mm. Diagonal scales are so called since diagonals are drawn in the rectangular part at the left-hand end of the scale.

The diagonals produce a series of similar triangles.

1. Draw a line 160 mm long.
2. Divide the line into four equal parts.
3. Draw 10 vertical divisions as shown and to any reasonable scale (say 5 mm) and add diagonals.

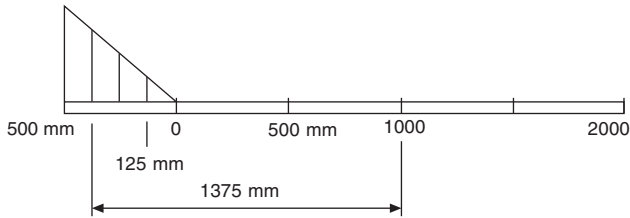
An example of reading the scale is given in Fig. 9.18.



**Fig. 9.18** Diagonal scale where 40 mm represents 1000 mm.

**Plain scales**

The method of drawing a plain scale is shown in Fig. 9.19. The example is for a plain scale of 30–500 mm to read by 125–2500 mm.



**Fig. 9.19** Plain scale where 30 mm represents 500 mm.



1. Draw a line 150 mm long and divide it into five equal parts.
2. Divide the first 30 mm length into four equal parts, and note the zero position, or the solution.


An example of a typical reading is given.



This method of calibration is in common use in industry, and scales can be obtained suitable for a variety of scale ratios.

## Abbreviations

With the increasing globalization of design and manufacture the use of abbreviations is now discouraged. However, in some areas of industry some abbreviations are commonly used and understood and where these exist their continuing use is permitted. The abbreviations in the following list are commonly understood by English speaking nations.

<b>A/F</b>	Across flats
<b>ASSY</b>	Assembly
<b>CRS</b>	Centers
<b>CL</b>	Center line
	(a) In a note
	(b) On a view and across a center line
<b>CG</b>	Centre of gravity
<b>CHAM</b>	Chamfer or chamfered (in a note)
<b>CH HD</b>	Cheese head
<b>CSK</b>	Countersunk/countersink
<b>CSK HD</b>	Countersunk head
<b>CBORE</b>	Counterbore
	Counterbore
	Countersink
<b>CYL</b>	Cylinder or cylindrical

	Deep
<b>DIA</b>	Diameter (a) In a note
<b>Ø</b>	(b) Preceding a dimension
<b>DIM</b>	Dimension
<b>DRG</b>	Drawing
<b>EQUI SP</b>	Equally spaced
<b>EXT</b>	External
<b>FIG</b>	Figure
<b>FIM</b>	Full indicated movement
<b>HEX</b>	Hexagon
<b>HEX HD</b>	Hexagon head
<b>INSUL</b>	Insulated or insulation
<b>INT</b>	Internal
<b>LMC</b>	Least material condition (a) In a note
<b>Ⓛ</b>	(b) Part of a geometrical tolerance
<b>LH</b>	Left hand
<b>LG</b>	Long
<b>MC</b>	Machine
<b>MATL</b>	Material
<b>MAX</b>	Maximum
<b>MMC</b>	Maximum material condition (a) In a note
<b>Ⓜ</b>	(b) Part of geometrical tolerance
<b>MIN</b>	Minimum
<b>NTS</b>	Not to scale (in a note and underlined)
<b>NO.</b>	Number
<b>PATT NO.</b>	Pattern number
<b>PCD</b>	Pitch circle diameter
	Radius
<b>RAD</b>	(a) In a note
<b>R</b>	(b) Preceding a dimension
<b>REF</b>	Reference
<b>REQD</b>	Required
<b>RH</b>	Right hand
<b>RD HD</b>	Round head
<b>SCR</b>	Screw or screwed
<b>SH</b>	Sheet (referring to a drawing sheet)
<b>SK</b>	Sketch (prefix to a drawing number)
<b>SPEC</b>	Specification
<b>Sø</b>	Spherical diameter (only preceding a dimension)
<b>SR</b>	Spherical radius (only preceding a dimension)

<b>SFACE</b>	Spotface
<b>SF</b>	Spotface
	Spotface
	Square
<b>SQ</b>	(a) In a note
<b>Or</b>	(b) Preceding a dimension
<b>STD</b>	Standard
	Taper (on diameter or width)
<b>THD</b>	Thread
<b>THK</b>	Thick
<b>TOL</b>	Tolerance
<b>TYP</b>	Typical or typically
<b>UCUT</b>	Undercut
<b>VOL</b>	Volume
<b>WT</b>	Weight

# Sections and sectional views

# 10

A section is used to show the detail of a component, or an assembly, on a particular plane which is known as the cutting plane. A simple bracket is shown in Fig. 10.1 and it is required to draw three sectional views. Assume that you had a bracket and cut it with a hacksaw along the line marked B–B. If you looked in the direction of the arrows then the end view B–B in the solution (Fig. 10.2) would face the viewer and the surface indicated by the cross hatching would be the actual metal which the saw had cut through. Alternatively had we cut along the line C–C then the plan in the solution would be the result. A rather special case exists along the plane A–A where in fact the thin web at this point has been sliced. Now if we were to cross-hatch all the surface we had cut through on this plane we would give a false impression of solidity. To provide a more realistic drawing, the web is defined by a full line and the base and perpendicular parts only have been cross-hatched. Note, that cross-hatching is never undertaken between dotted lines, hence the full line between the web and the remainder of the detail. However, the boundary at this point is theoretically a dotted line since the casting is formed in one piece and no join exists here. This standard drawing convention is frequently tested on examination papers.

Cutting planes are indicated on the drawing by a long chain line 0.35 mm thick and thickened at both ends to 0.7 mm. The cutting plane is lettered and the arrows indicate the direction of viewing. The sectional view or plan must then be stated to be A–A, or other letters appropriate to the cutting plane. The cross-hatching should always be at 45° to the center lines, with continuous lines 0.35 mm thickness.

If the original drawing is to be microfilmed successive lines should not be closer than 4 mm as hatching lines tend to merge with much reduced scales. When hatching very small areas, the minimum distance between lines should not be less than 1 mm.

In the case of very large areas, cross hatching may be limited to a zone which follows the contour of the hatched area. On some component detail drawings it may be necessary to add dimensions to a sectional drawing and the practise is to interrupt the cross-hatching so that the letters and numbers are clearly visible.

Fig. 10.3 shows three typical cases of cross-hatching. Note that the hatching lines are equally spaced and drawn at an angle of 45° to the principal center line in each example.

A bush is shown in Fig. 10.4 in a housing. There are two adjacent parts and each is cross-hatched in opposite directions. It is customary to reduce the pitch between hatching lines for the smaller part.

If the interior of a component is of an intricate nature or it contains several parts to form an assembly, then the customary orthographic drawing would contain a confusion of dotted lines, which, in addition to being difficult to draw could also be terribly difficult to understand. The reader of any engineering drawing should be able to obtain

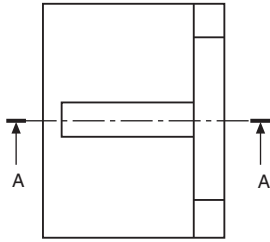
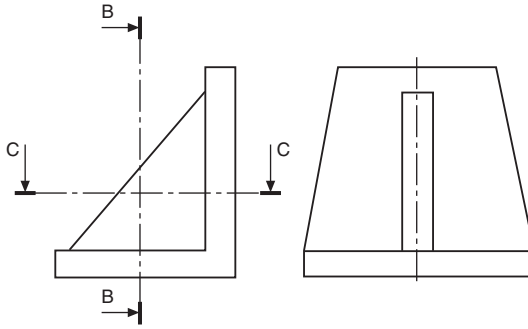


Fig. 10.1 Orthographic views of a bracket with section cutting planes.

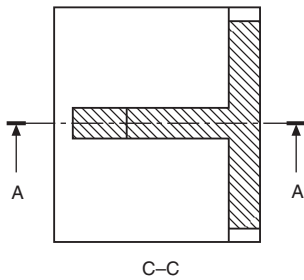
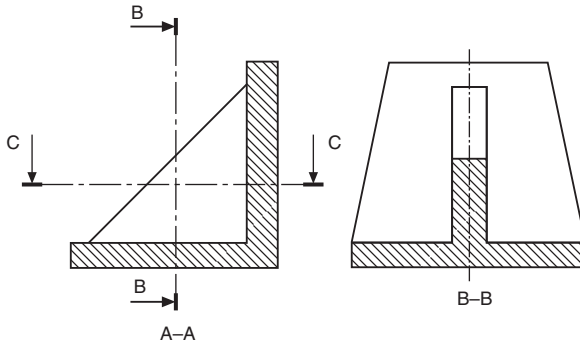
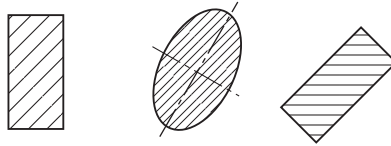
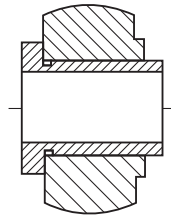


Fig. 10.2 Bracket sectioned along cutting planes.



**Fig. 10.3** Examples of cross hatching.



**Fig. 10.4** Hatching of two adjacent parts.

only one positive interpretation of the component, or the designer has failed in their duty. Sectional drawings are prepared which cut away a portion of the component to reveal internal details, and certain standard conventions have been established to cover this aspect of drawing practice.

[Fig. 10.5](#) shows some advantages of drawing a sectional view with a small cast component.

Note, that in Plan (A), the sectional plan gives clearly the exact outline along the horizontal axis where the casting has assumed to have been cut. This contrasts with the confusion in Plan (B) which obviously results from attempting to include all the detail by inserting the appropriate dotted lines.

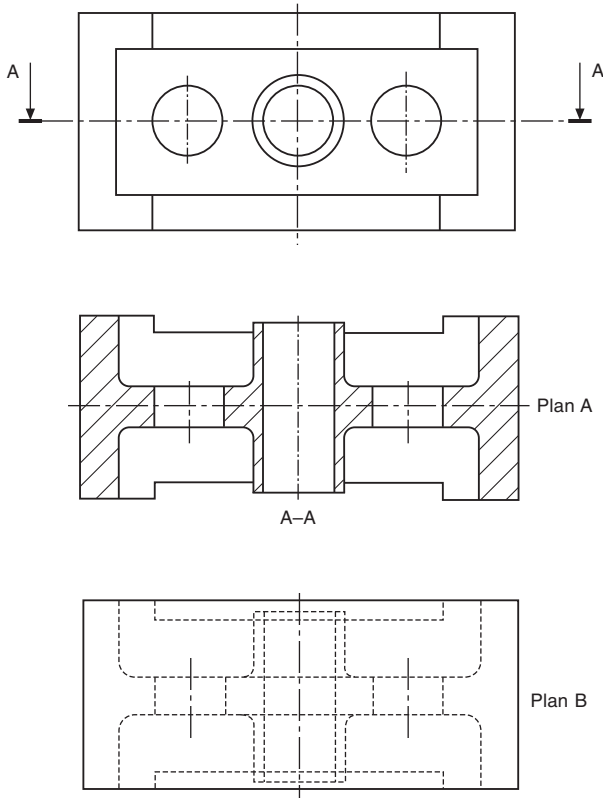
Where the location of a single cutting plane is obvious, no indication of its position or identification is required. [Fig. 10.6](#) gives a typical example.

## Half sections

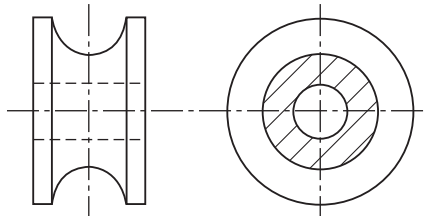
Symmetrical parts may be drawn half in section and half in outside view. This type of drawing avoids the necessity of introducing dotted lines for the holes and the recess. Dimensioning to dotted lines is not a recommended practice ([Fig. 10.7](#)).

## Revolved sections

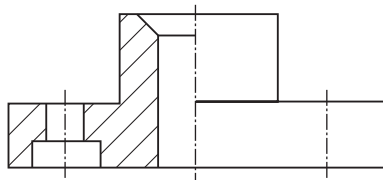
A special spanner is illustrated in [Fig. 10.8](#). A revolved section is shown on the handle to indicate the shape of the cross-section at that point. This is a convenient convention to use on single view drawings because the shape could not be confirmed without projecting a second view or an added note.



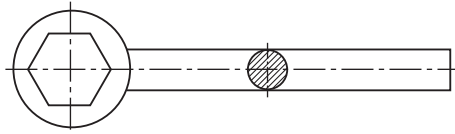
**Fig. 10.5** Sectional view added to a drawing for clarity.



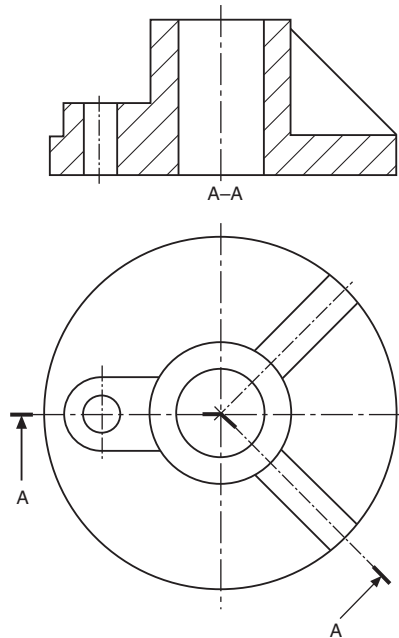
**Fig. 10.6** Sectional view without cutting plane.



**Fig. 10.7** Half section.



**Fig. 10.8** Revolved section without cutting plane.



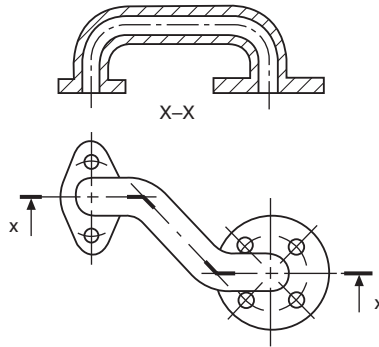
**Fig. 10.9** Revolved section on two cutting planes.

A second type of revolved section in Fig. 10.9 shows a case where it is required to indicate details on two separate intersecting planes. The elevation in section has been drawn assuming that the right-hand plane has been revolved to the horizontal position. Note that the thin web is not cross-hatched.

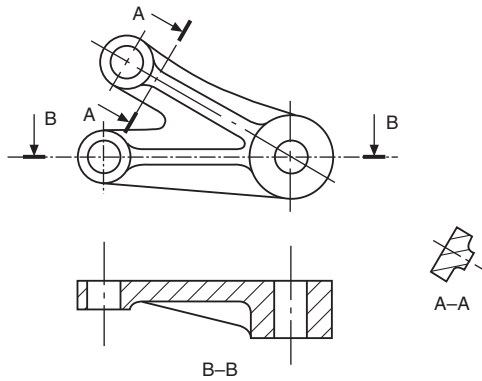
Fig. 10.10 shows a sectioned elevation from a plan where the section line is taken along three neighboring planes which are not at right angles to one another. The section line follows the section planes in order, and is thickened at each change of direction.

## Removed sections

A removed section is shown in Fig. 10.11. Note that no additional background information has been included, since the removed section only indicates the true shape of the casting at the point where the section has been taken. B-B gives the section along the horizontal center line through the thin web.



**Fig. 10.10** Section along three cutting planes.



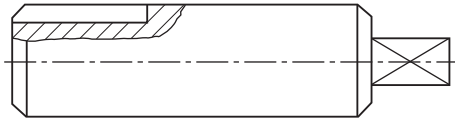
**Fig. 10.11** Removed sections.

## Sections through thin material

Many products are manufactured from very thin materials which would be virtually impossible to cross-hatch in a sectional view and in these cases it is usual to make them entirely black. However, if two or more thin sections are adjacent to each other, a gap is left so that the profile of the separate components is clearly defined. A compound stanchion used in structural steelwork and drawn to the reduced scale is shown in Fig. 10.12. The same situation applies with sections through sheet-metal fabrications, gaskets, seals, and packings.



**Fig. 10.12** Section through thin material.



**Fig. 10.13** Local section.

## Local sections

It is not always necessary to draw a complete section through a component if a small amount of detail only needs to be illustrated. A typical example is shown in [Fig. 10.13](#) where a keyway is drawn in a section. The irregular line defines the boundary of the section. It is not required to add a section plane to this type of view.

## Components not drawn in section

It is the custom not to section many recognizable components in assembly drawings positioned along the cutting plane; these include nuts, bolts, washers, rivets, pins, keys, balls, rollers, spokes of wheels, and similar symmetrical parts.

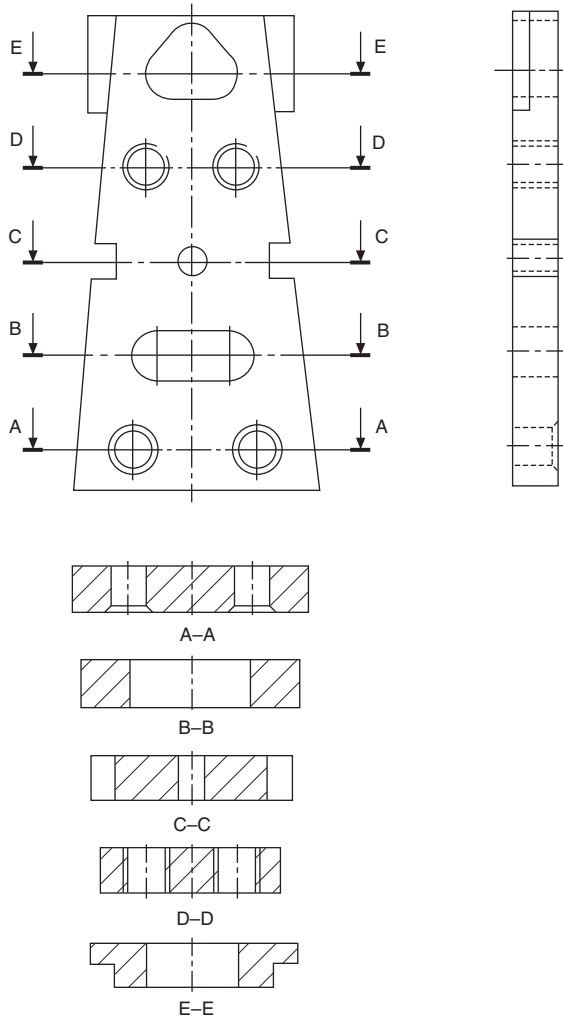
## Successive sections

[Fig. 10.14](#) shows the front and end elevations of a special purpose mounting plate where sectional plans are given at different levels to illustrate the shapes of the various cutouts and details. Now it will be noted that the presentation of this problem takes considerable vertical space since all of the plan views are in correct projection.

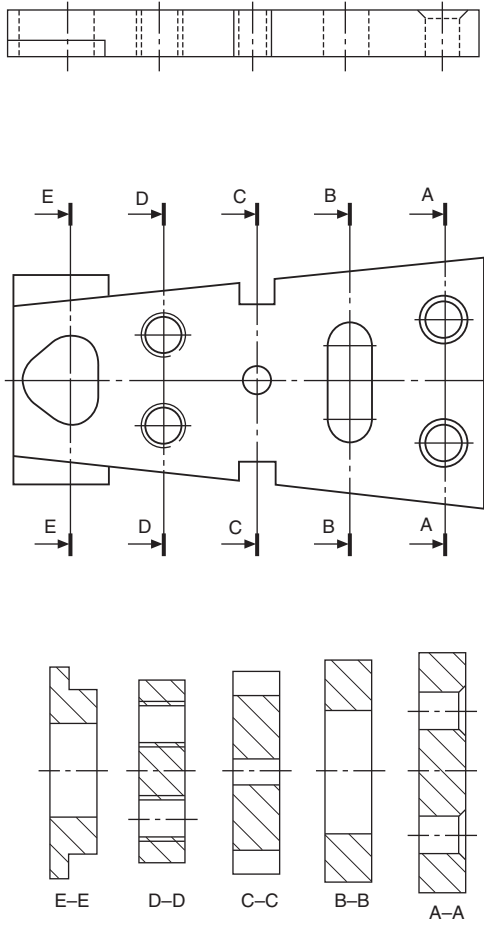
Note that where successive sections are drawn, each view only gives the detail at that section plane and not additional background information. [Fig. 10.15](#) gives the details at each of the section planes in a much closer and less remote arrangement.

## Sections in two parallel planes

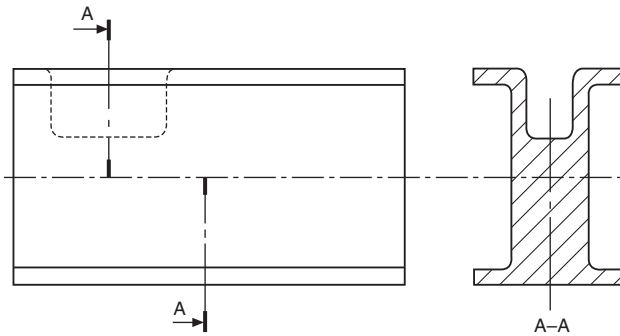
[Fig. 10.16](#) shows a method of presenting two sections from parallel planes along the same part.



**Fig. 10.14** Multi sectioned part - vertical.



**Fig. 10.15** Multi sectioned part - horizontal.



**Fig. 10.16** Section in two parallel planes.

# Geometrical constructions and tangency

# 11

Students will often experience difficulty in handling problems involving two- and three-dimensional geometrical constructions. The examples in this chapter are included in order to provide a background in solving engineering problems connected with lines, planes, and space. The separate chapters are grouped around applications having similar principles.

Copying a selection of these examples on the drawing board or on CAD equipment will certainly enable the reader to gain confidence. It will assist them to visualize and position the lines in space which form each part of a view, or the boundary, of a three-dimensional object. It is a necessary part of draughting to be able to justify every line and dimension which appears on a drawing correctly.

Many software programs will offer facilities to perform a range of constructions, for example tangents, ellipses, and irregular curves. Use these features where possible in the examples which follow.

Assume all basic dimensions where applicable.

## To bisect a given angle AOB (Fig. 11.1)

1. With center O, draw an arc to cut OA at C and OB at D.
2. With centers C and D, draw equal radii to intersect at E.
3. Line OE bisects angle AOB.

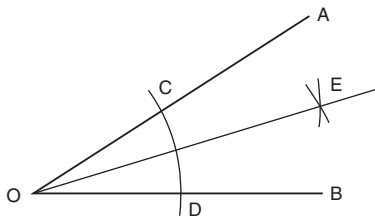
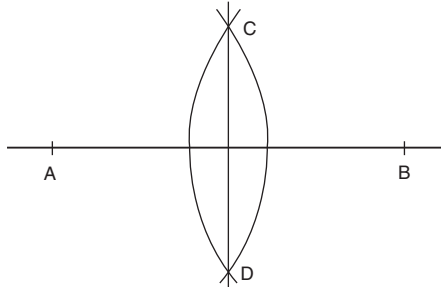


Fig. 11.1 Bisect an angle.

## To bisect a given straight line AB (Fig. 11.2)

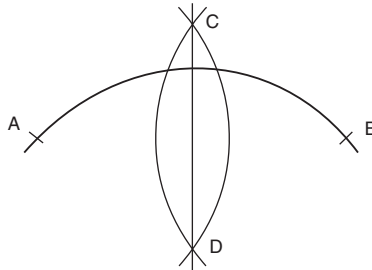
1. With center A and radius greater than half AB, describe an arc.
2. Repeat with the same radius from B, the arcs intersecting at C and D.
3. Joining C to D, this line will be perpendicular to and bisect AB.



**Fig. 11.2** Bisect a straight line.

### To bisect a given arc AB (Fig. 11.3)

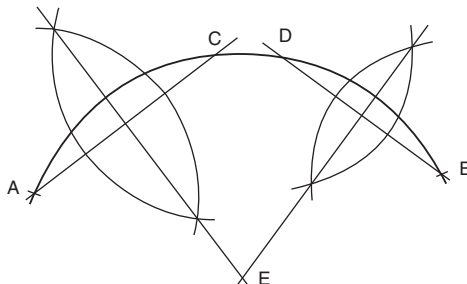
1. With center A and radius greater than half AB, describe an arc.
2. Repeat with the same radius from B, the arcs intersecting at C and D.
3. Join C to D to bisect the arc AB.



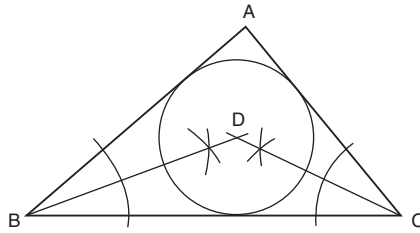
**Fig. 11.3** Bisect an arc.

### To find the center of a given arc AB (Fig. 11.4)

1. Draw two chords, AC and BD.
2. Bisect AC and BD as shown; the bisectors will intersect at E.
3. The center of the arc is point E.



**Fig. 11.4** Center of an arc.



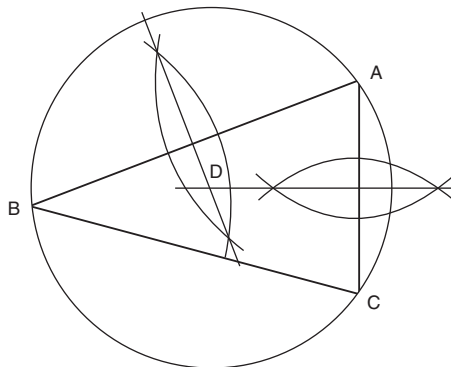
**Fig. 11.5** Inscribe a circle within a triangle.

### To inscribe a circle in a given triangle ABC (Fig. 11.5)

1. Bisect any two of the angles as shown so that the bisectors intersect at D.
2. The center of the inscribed circle is point D.

### To circumscribe a circle around triangle ABC (Fig. 11.6)

1. Bisect any two of the sides of the triangle as shown, so that the bisectors intersect at D.
2. The center of the circumscribing circle is point D.

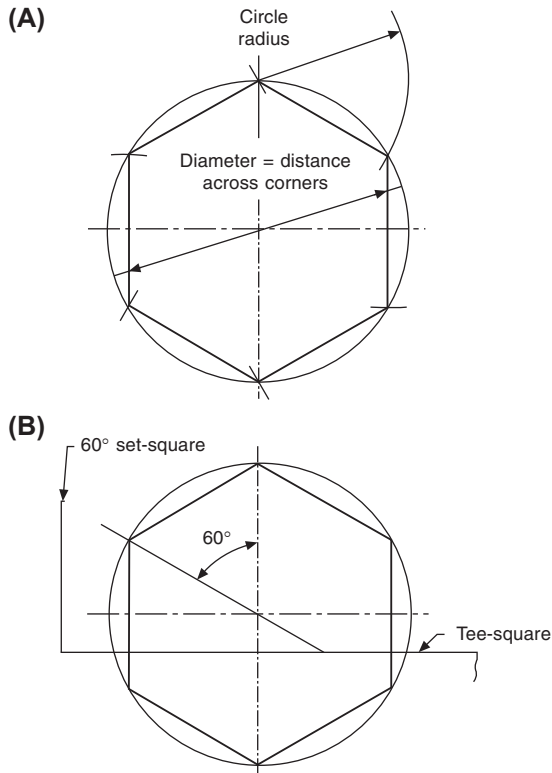


**Fig. 11.6** Circumscribe a circle around a triangle.

### To draw a hexagon, given the distance across the corners

#### Method A (Fig. 11.7)

1. Draw vertical and horizontal center lines and a circle with a diameter equal to the given distance.



**Fig. 11.7** Hexagon - across corner methods.

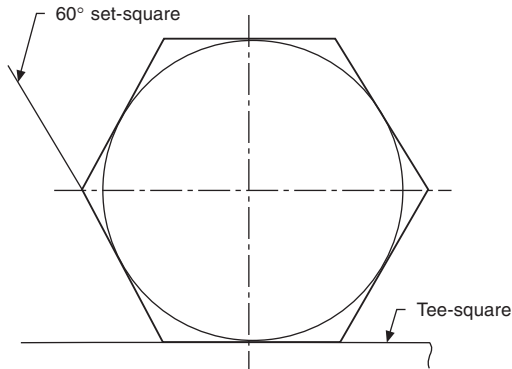
2. Step off the radius around the circle to give six equally spaced points, and join the points to give the required hexagon.

### **Method B (Fig. 11.7A)**

1. Draw vertical and horizontal center lines and a circle with a diameter equal to the given distance.
2. With a  $60^\circ$  set-square, draw points on the circumference  $60^\circ$  apart.
3. Connect these six points by straight lines to give the required hexagon.

## **To draw a hexagon, given the distance across the flats (Fig. 11.8)**

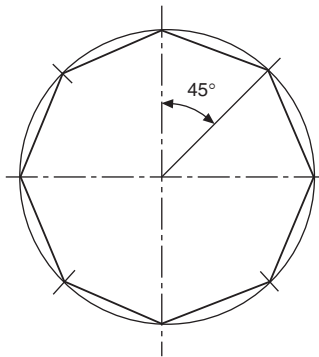
1. Draw vertical and horizontal center lines and a circle with a diameter equal to the given distance.
2. Use a  $60^\circ$  set-square and tee-square as shown, to give the six sides.



**Fig. 11.8** Hexagon - across flat method.

### To draw a regular octagon, given the distance across corners (**Fig. 11.9**)

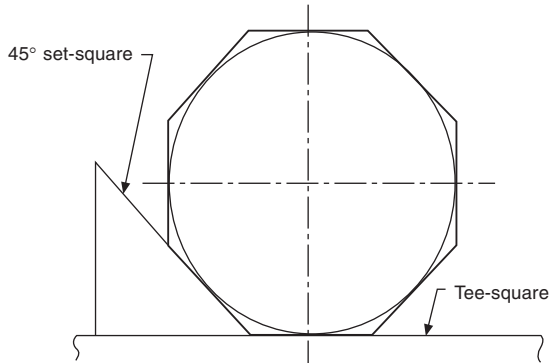
Repeat the instructions in **Fig. 11.7B** but use a  $45^\circ$  set-square, then connect the eight points to give the required octagon.



**Fig. 11.9** Octagon - across corner method.

### To draw a regular octagon, given the distance across the flats (**Fig. 11.10**)

Repeat the instructions in **Fig. 11.8** but use a  $45^\circ$  set-square to give the required octagon.

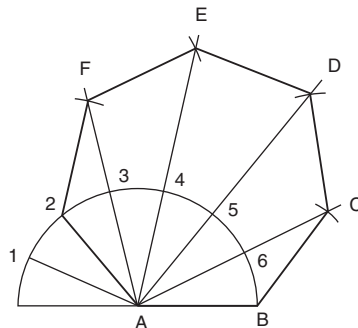


**Fig. 11.10** Octagon - across flat method.

## To draw a regular polygon, given the length of the sides (Fig. 11.11)

Note that a regular polygon is defined as a plane figure which is bounded by straight lines of equal length and which contains angles of equal size. Assume the number of sides is seven in this example.

1. Draw the given length of one side AB, and with radius AB describe a semi-circle.
2. Divide the semi-circle into seven equal angles, using a protractor, and through the second division from the left join line A2.
3. Draw radial lines from A through points 3, 4, 5, and 6.
4. With radius AB and center on point 2, describe an arc to meet the extension of line A3, shown here as point F.
5. Repeat with radius AB and center F to meet the extension of line A4 at E.
6. Connect the points as shown, to complete the required polygon.



**Fig. 11.11** Polygon - length of side method.

## Tangency

If a disc stands on its edge on a flat surface it will touch the surface at one point. This point is known as the *point of tangency*, as shown in Fig. 11.12 and the straight line which represents the flat plane is known as a tangent. A line drawn from the point of tangency to the center of the disc is called a 'normal', and the tangent makes an angle of  $90^\circ$  with the normal.

The following constructions show the methods of drawing tangents in various circumstances.

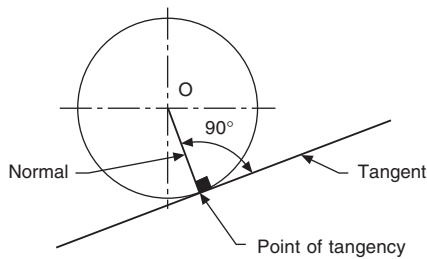


Fig. 11.12 Point of tangency.

### To draw a tangent to a point *a* on the circumference of a circle, center *O* (Fig. 11.13)

Join *OA* and extend the line for a short distance. Erect a perpendicular at point *A* by the method shown.

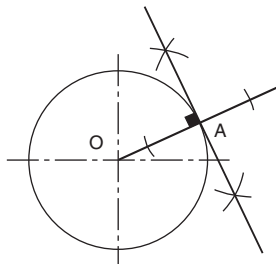
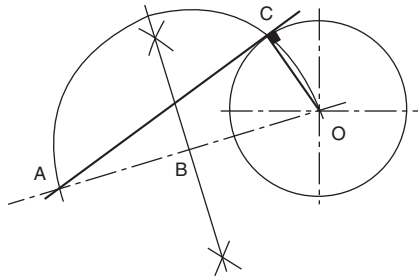


Fig. 11.13 Tangent to a circle from a point on circumference.

### To draw a tangent to a circle from any given point *a* outside the circle (Fig. 11.14)

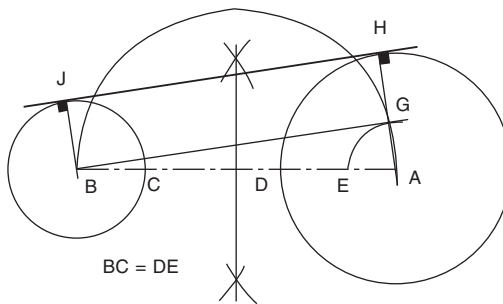
Join *A* to the center of the circle *O*. Bisect line *AO* so that point *B* is the mid-point of *AO*. With center *B*, draw a semi-circle to intersect the given circle at point *C*. Line *AC* is the required tangent.



**Fig. 11.14** Tangent to a circle from a point outside the circle.

### To draw an external tangent to two circles (Fig. 11.15)

Join the centers of the circles by line AB, bisect AB, and draw a semi-circle. Position point E so that DE is equal to the radius of the smaller circle. Draw radius AE to cut the semi-circle at point G. Draw line AGH so that H lies on the circumference of the larger circle. Note that angle AGB lies in a semi-circle and will be  $90^\circ$ . Draw line HJ parallel to BG. Line HJ will be tangential to the two circles and lines BJ and AGH are the normals.



**Fig. 11.15** External tangent to two circles.

### To draw an internal tangent to two circles (Fig. 11.16)

Join the centers of the circles by line AB, bisect AB and draw a semi-circle. Position point E so that DE is equal to the radius of the smaller circle BC. Draw radius AE to cut the semi-circle at H. Join AH; this line crosses the larger circle circumference at J. Draw line BH. From J draw a line parallel to BH to touch the smaller circle at K. Line JK is the required tangent. Note that angle AHB lies in a semi-circle and will therefore be  $90^\circ$ . AJ and BK are normals.

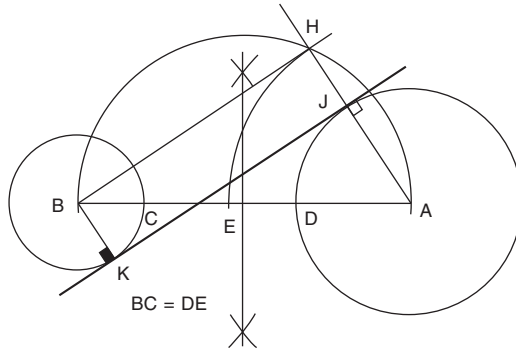


Fig. 11.16 Internal tangent to two circles.

**To draw internal and external tangents to two circles of equal diameter (Fig. 11.17)**

Join the centers of both circles by line AB. Erect perpendiculars at points A and B to touch the circumferences of the circles at points C and D. Line CD will be the external tangent. Bisect line AB to give point E; then bisect BE to give point G. With radius BG, describe a semi-circle to cut the circumference of one of the given circles at H. Join HE and extend it to touch the circumference of the other circle at J. Line HEJ is the required tangent. Note that again the angle in the semi-circle, BHE, will be  $90^\circ$ , and hence BH and AJ are normals.

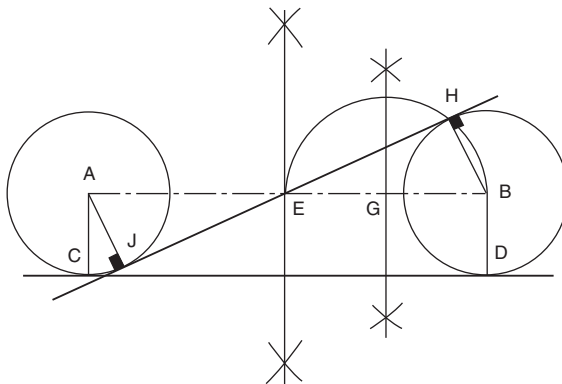
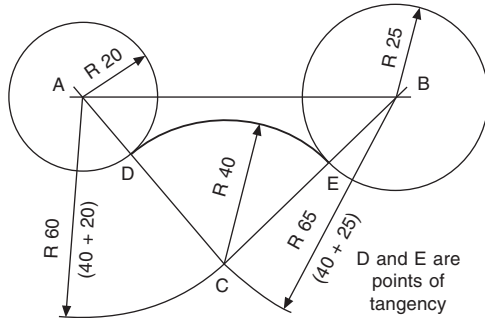


Fig. 11.17 Internal and external tangents of equal diameter.

**To draw a curve of given radius to touch two circles when the circles are outside the radius (Fig. 11.18)**

Assume that the radii of the given circles are 20 and 25 mm, spaced 85 mm apart, and that the radius to touch them is 40 mm.



**Fig. 11.18** Curve between two external circles.

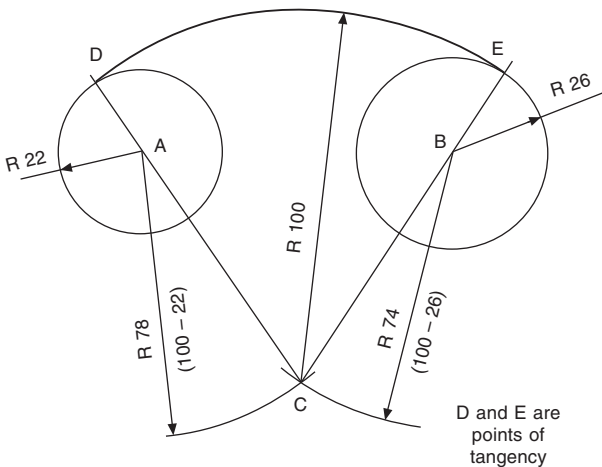
With center A, describe an arc equal to  $20 + 40 = 60$  mm.

With center B, describe an arc equal to  $25 + 40 = 65$  mm.

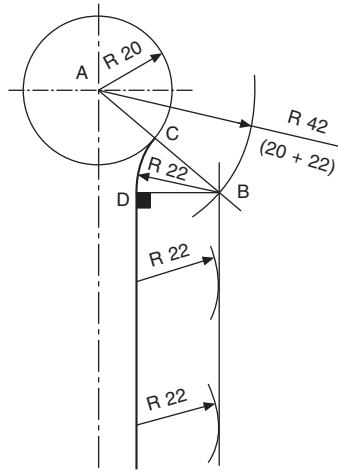
The above arcs intersect at point C. With a radius of 40 mm, describe an arc from point C as shown, and note that the points of tangency between the arcs lie along the lines joining the centers AC and BC. It is particularly important to note the position of the points of tangency before lining in engineering drawings, so that the exact length of an arc can be established.

**To draw a curve of given radius to touch two circles when the circles are inside the radius (Fig. 11.19)**

Assume that the radii of the given circles are 22 and 26 mm, spaced 86 mm apart, and that the radius to touch them is 100 mm.



**Fig. 11.19** Curve between two internal circles.



**Fig. 11.20** Radius joining a straight line and circle.

With center A, describe an arc equal to  $100 - 22 = 78$  mm.

With center B, describe an arc equal to  $100 - 26 = 74$  mm.

The above arcs intersect at point C. With a radius of 100 mm, describe an arc from point C, and note that in this case the points of tangency lie along line CA extended to D and along line CB extended to E.

## To draw a radius to join a straight line and a given circle (Fig. 11.20)

Assume that the radius of the given circle is 20 mm and that the joining radius is 22 mm.

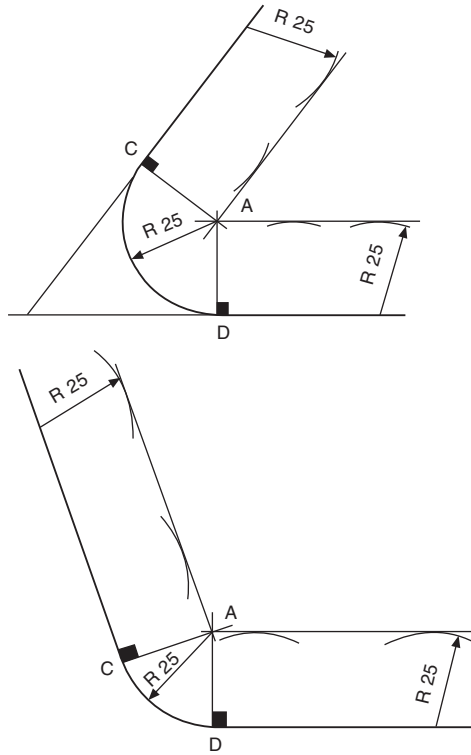
With center A, describe an arc equal to  $20 + 22 = 42$  mm.

Draw a line parallel to the given straight line and at a perpendicular distance of 22 mm from it, to intersect the arc at point B.

With center B, describe the required radius of 22 mm, and note that one point of tangency lies on the line AB at C; the other lies at point D such that BD is at  $90^\circ$  to the straight line.

## To draw a radius which is tangential to given straight lines (Fig. 11.21)

Assume that a radius of 25 mm is required to touch the lines shown in the figure. Draw lines parallel to the given straight lines and at a perpendicular distance of



**Fig. 11.21** Radius tangent to straight lines.

25 mm from them to intersect at point A. As above, note that the points of tangency are obtained by drawing perpendiculars through the point A to the straight lines in each case.

If a point, line, or surface moves according to a mathematically defined condition, then a curve known as a *locus* is formed. The following examples of curves and their constructions are widely used and applied in all types of engineering.

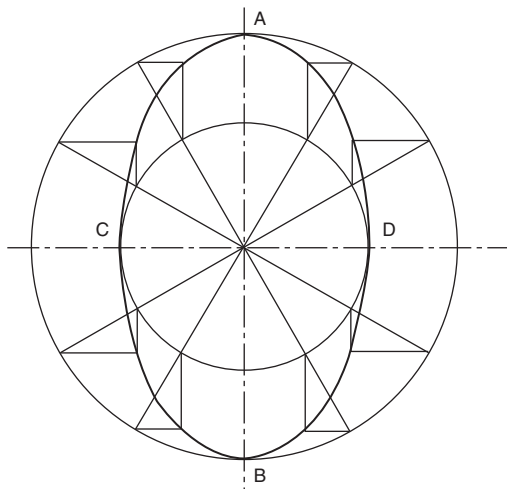
## Methods of drawing an ellipse

### *Two-circle method*

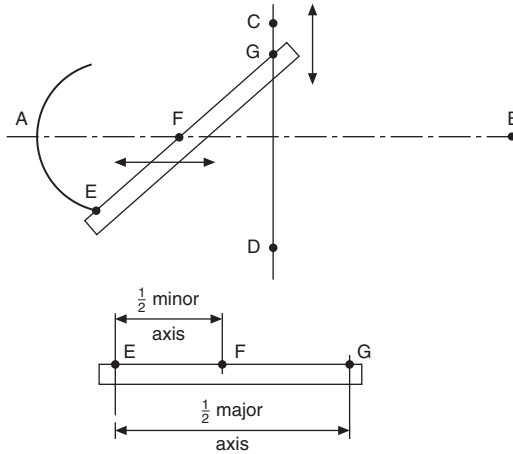
Construct two concentric circles equal in diameter to the major and minor axes of the required ellipse. Let these diameters be AB and CD in Fig. 12.1.

Divide the circles into any number of parts; the parts do not necessarily have to be equal. The radial lines now cross the inner and outer circles.

Where the radial lines cross the outer circle, draw short lines parallel to the minor axis CD. Where the radial lines cross the inner circle, draw lines parallel to AB to intersect with those drawn from the outer circle. The points of intersection lie on the ellipse. Draw a smooth connecting curve.



**Fig. 12.1** Two-circle construction for an ellipse.



**Fig. 12.2** Trammel method for ellipse construction.

### **Trammel method**

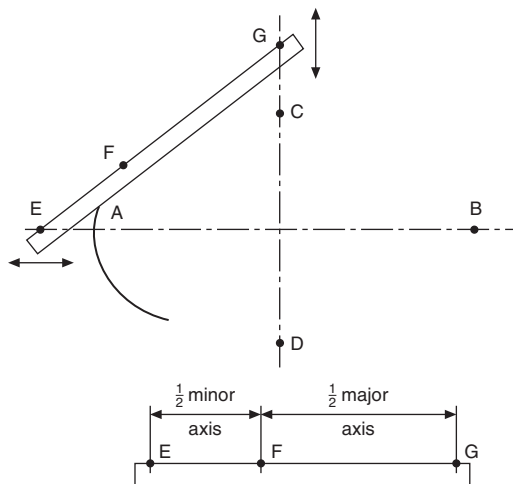
Draw major and minor axes at right angles, as shown in [Fig. 12.2](#).

Take a strip of paper for a trammel and mark on it half the major and minor axes, both measured from the same end. Let the points on the trammel be E, F, and G.

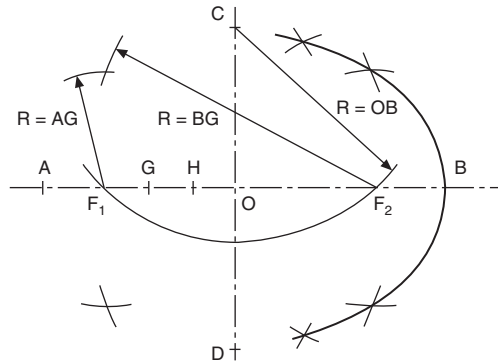
Position the trammel on the drawing so that point F always lies on the major axis AB and point G always lies on the minor axis CD. Mark the point E with each position of the trammel, and connect these points to give the required ellipse.

Note that this method relies on the difference between half the lengths of the major and minor axes, and where these axes are nearly the same in length, it is difficult to position the trammel with a high degree of accuracy. The following alternative method can be used.

Draw major and minor axes as before, but extend them in each direction as shown in [Fig. 12.3](#).



**Fig. 12.3** Alternative trammel method.



**Fig. 12.4** Ellipse by foci method.

Take a strip of paper and mark half of the major and minor axes in line, and let these points on the trammel be E, F, and G.

Position the trammel on the drawing so that point G always moves along the line containing CD; also, position point E along the line containing AB. For each position of the trammel, mark point F and join these points with a smooth curve to give the required ellipse.

### ***To draw an ellipse using the two foci***

Draw major and minor axes intersecting at point O, as shown in Fig. 12.4. Let these axes be AB and CD. With a radius equal to half the major axis AB, draw an arc from center C to intersect AB at points  $F_1$  and  $F_2$ . These two points are the foci. For any ellipse, the sum of the distances  $PF_1$  and  $PF_2$  is a constant, where P is any point on the ellipse. The sum of the distances is equal to the length of the major axis.

Divide distance  $OF_1$  into equal parts. Three are shown here, and the points are marked G and H.

With center  $F_1$  and radius AG, describe an arc above and beneath line AB.

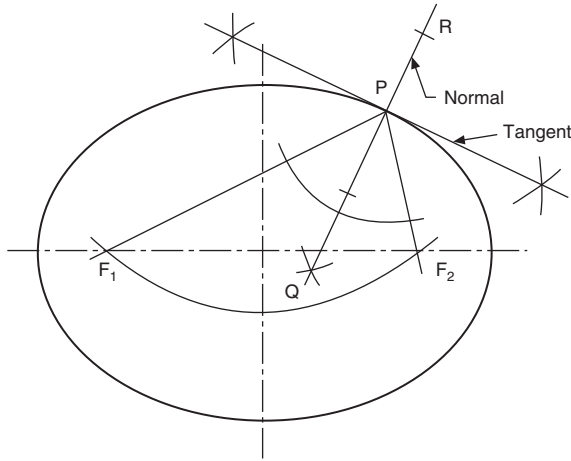
With center  $F_2$  and radius BG, describe an arc to intersect the above arcs.

Repeat these two steps by firstly taking radius AG from point  $F_2$  and radius BG from  $F_1$ .

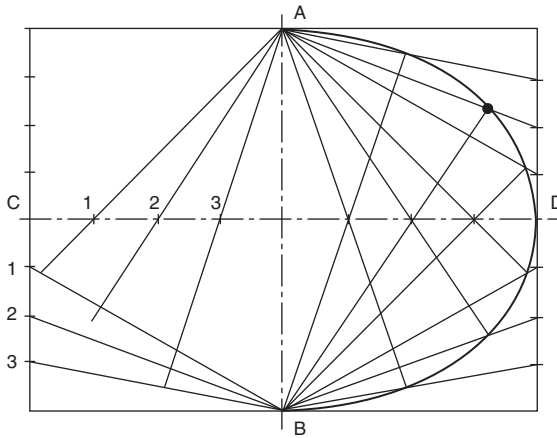
The above procedure should now be repeated using radii AH and BH. Draw a smooth curve through these points to give the ellipse.

It is often necessary to draw a tangent to a point on an ellipse. In Fig. 12.5 P is any point on the ellipse, and  $F_1$  and  $F_2$  are the two foci. Bisect angle  $F_1PF_2$  with line QPR. Erect a perpendicular to line QPR at point P, and this will be a tangent to the ellipse at point P. The methods of drawing ellipses illustrated above are all accurate. Approximate ellipses can be constructed as follows.

*Approximate method 1:* Draw a rectangle with sides equal in length to the major and minor axes of the required ellipse, as shown in Fig. 12.6.



**Fig. 12.5** Tangency to an ellipse.



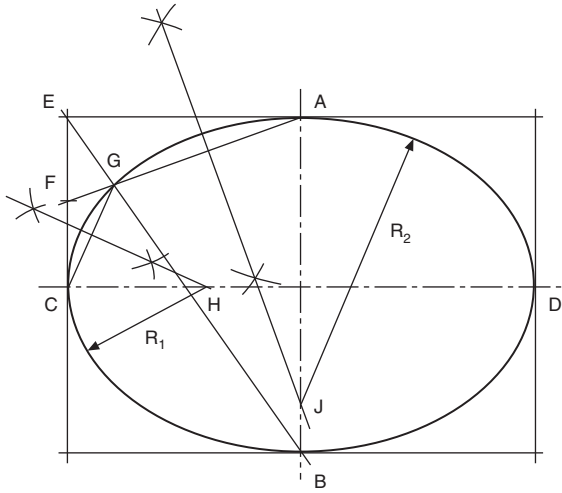
**Fig. 12.6** Tangency to an ellipse approximate method 1.

Divide the major axis into an equal number of parts; eight parts are shown here. Divide the side of the rectangle into the same equal number of parts. Draw a line from A through point 1, and let this line intersect the line joining B to point 1 at the side of the rectangle as shown. Repeat for all other points in the same manner, and the resulting points of intersection will lie on the ellipse.

*Approximate method 2:* Draw a rectangle with sides equal to the lengths of the major and minor axes, as shown in Fig. 12.7.

Bisect EC to give point F. Join AF and BE to intersect at point G. Join CG. Draw the perpendicular bisectors of lines CG and GA, and these will intersect the center lines at points H and J.

Using radii CH and JA, the ellipse can be constructed by using four arcs of circles.



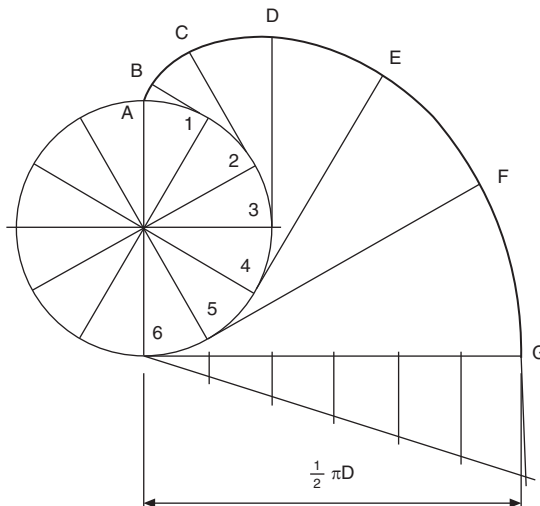
**Fig. 12.7** Tangency to an ellipse approximate method 2.

## The involute

The involute is defined as the path of a point on a straight line which rolls without slip along the circumference of a cylinder. The involute curve will be required in a later chapter for the construction of gear teeth.

### *Involute construction*

1. Draw the given base circle and divide it into, say, 12 equal divisions as shown in [Fig. 12.8](#). Generally only the first part of the involute is required, so the given diagram shows a method using half of the length of the circumference.



**Fig. 12.8** Involute construction.

2. Draw tangents at points 1, 2, 3, 4, 5, and 6.
3. From point 6, mark off a length equal to half the length of the circumference.
4. Divide line 6G into six equal parts.
5. From point 1, mark point B such that 1B is equal to one part of line 6G.
6. From point 2, mark point C such that 2C is equal to two parts of line 6G.
  1. Repeat the above procedure from points 3, 4, and 5, increasing the lengths along the tangents as before by one part of line 6G.
7. Join points A and G, to give the required involute.

### ***Alternative method***

1. As above, draw the given base circle, divide into, say, 12 equal divisions, and draw the tangents from points 1 to 6.
2. From point 1 and with radius equal to the chordal length from point 1 to point A, draw an arc terminating at the tangent from point 1 at point B.
3. Repeat the above procedure from point 2 with radius 2B terminating at point C.
4. Repeat the above instructions to obtain points D, E, F, and G, and join points A and G to give the required involute.

The alternative method given is an approximate method, but is reasonably accurate provided that the arc length is short; the difference in length between the arc and the chord introduces only a minimal error.

## **Archimedean spiral**

The Archimedean spiral is the locus of a point which moves around a center at uniform angular velocity and at the same time moves away from the center at uniform linear velocity. The construction is shown in [Fig. 12.9](#).

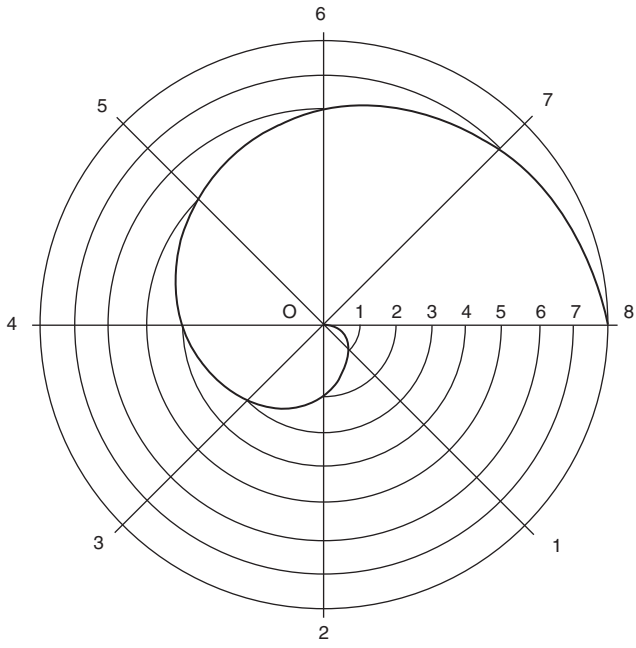
1. Given the diameter, divide the circle into an even number of divisions and number them.
2. Divide the radius into the same number of equal parts.
3. Draw radii as shown to intersect radial lines with corresponding numbers, and connect points of intersection to give the required spiral.

Note that the spiral need not start at the center; it can start at any point along a radius, but the divisions must be equal.

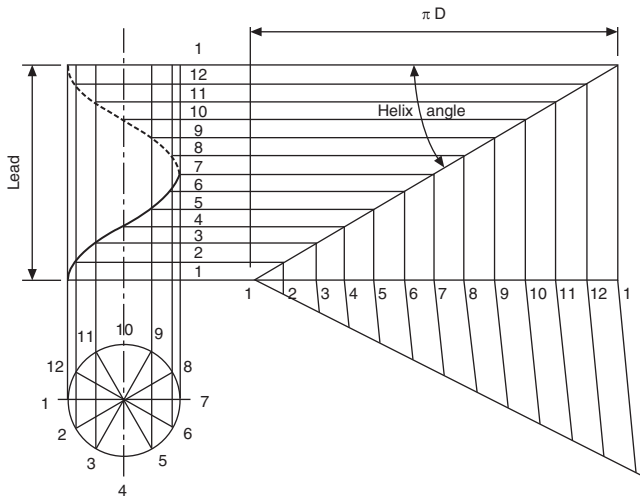
Self-centring lathe chucks utilize Archimedean spirals.

## **Right-hand cylindrical helix**

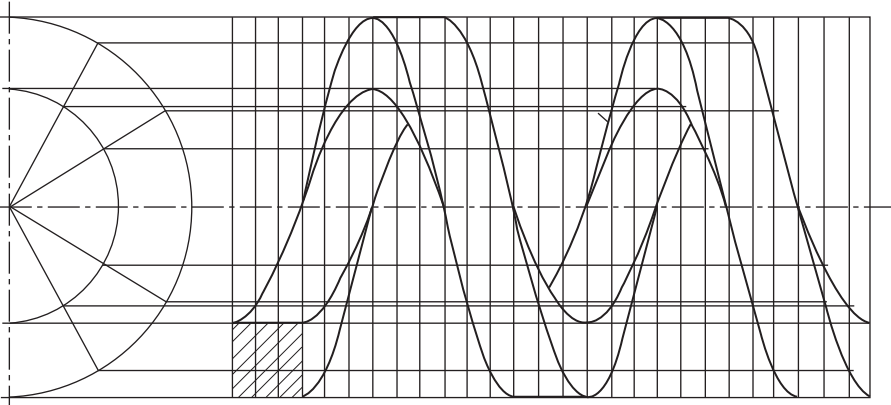
The helix is a curve generated on the surface of the cylinder by a point which revolves uniformly around the cylinder and at the same time either up or down its surface. The method of construction is shown in [Fig. 12.10](#).



**Fig. 12.9** Archimedean spiral.



**Fig. 12.10** Right-hand cylindrical helix.



**Fig. 12.11** Square-section right-hand helical spring.

1. Draw the front elevation and plan views of the cylinder, and divide the plan view into a convenient number of parts (say 12) and number them as shown.
2. Project the points from the circumference of the base up to the front elevation.
3. Divide the lead into the same number of parts as for the base, and number them as shown.
4. Draw lines of intersection from the lead to correspond with the projected lines from the base.
5. Join the points of intersection, to give the required cylindrical helix.
6. If a development of the cylinder is drawn, the helix will be projected as a straight line. The angle between the helix and a line drawn parallel with the base is known as the helix angle.

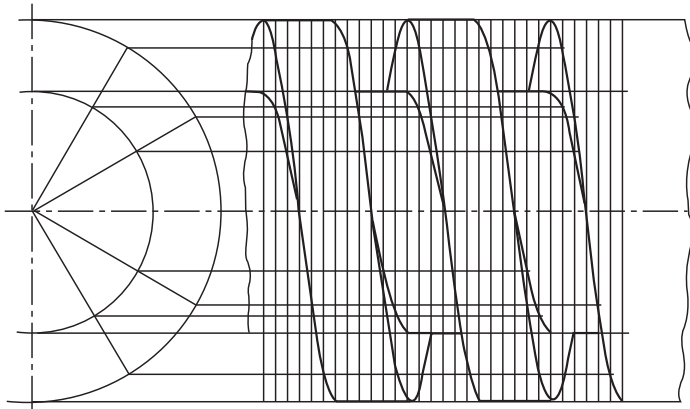
*Note:* If the numbering in the plan view is taken in the clockwise direction from point 1, then the projection in the front elevation will give a left-hand helix.

The construction for a helix is shown applied to a right-hand helical spring in [Fig. 12.11](#). The spring is of square cross-section, and the four helices are drawn from the two outside corners and the two corners at the inside diameter. The pitch of the spring is divided into 12 equal parts, to correspond with the 12 equal divisions of the circle in the end elevation, although only half of the circle need be drawn. Points are plotted as previously shown.

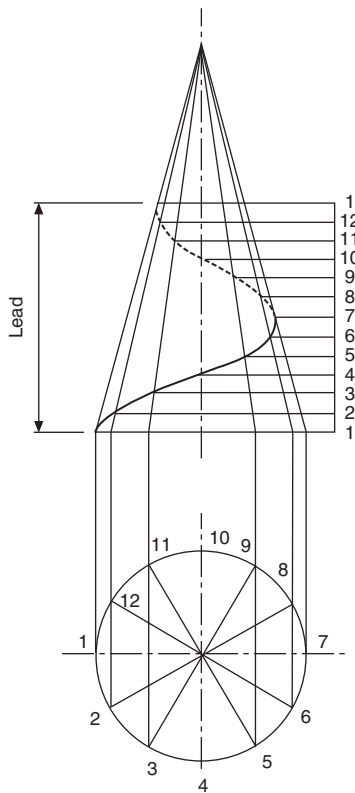
A single-start square thread is illustrated in [Fig. 12.12](#). The construction is similar to the previous problem, except that the center is solid metal. Four helices are plotted, spaced as shown, since the thread width is half the pitch.

## Right-hand conical helix

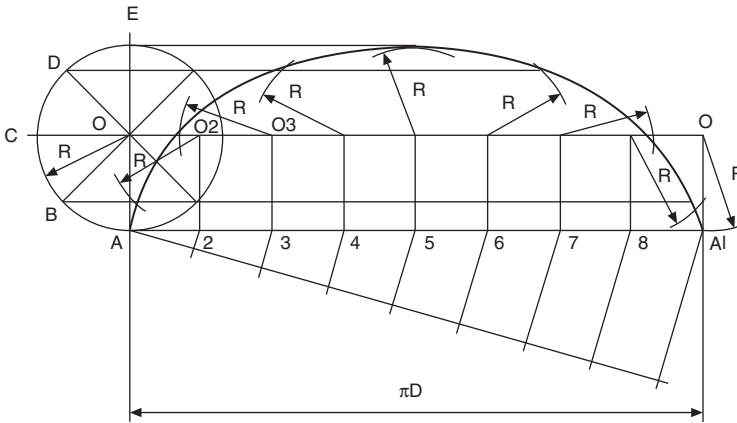
The conical helix is a curve generated on the surface of the cone by a point which revolves uniformly around the cone and at the same time either up or down its surface. The method of construction is shown in [Fig. 12.13](#).



**Fig. 12.12** Single-start square thread.



**Fig. 12.13** Right-hand conical helix.



**Fig. 12.14** Cycloid.

1. Draw the front elevation and plan of the cone, and divide the plan view into a convenient number of parts (say 12) and number them as shown.
2. Project the points on the circumference of the base up to the front elevation, and continue the projected lines to the apex of the cone.
3. The lead must now be divided into the same number of parts as for the base, and numbered.
4. Draw lines of intersection from the lead to correspond with the projected lines from the base.
5. Join the points of intersection, to give the required conical helix.

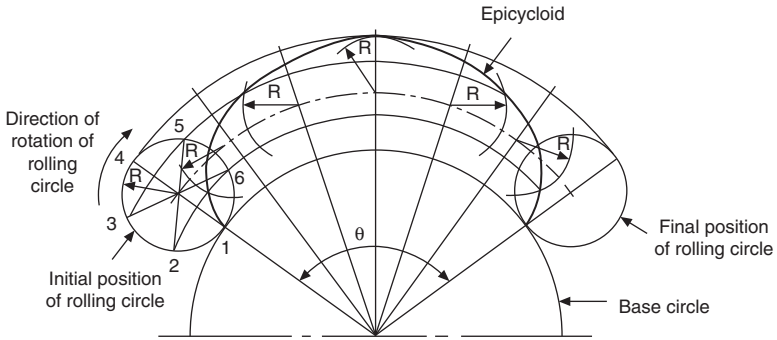
## The cycloid

The cycloid is defined as the locus of a point on the circumference of a cylinder which rolls without slip along a flat surface. The method of construction is shown in Fig. 12.14.

1. Draw the given circle, and divide into a convenient number of parts; eight divisions are shown in Fig. 12.14.
2. Divide line  $AA_1$  into eight equal lengths. Line  $AA_1$  is equal to the length of the circumference.
3. Draw vertical lines from points 2 to 8 to intersect with the horizontal line from center O at points  $O_2, O_3$ , etc.
4. With radius OA and center  $O_2$ , describe an arc to intersect with the horizontal line projected from B.
5. Repeat with radius OA from center  $O_3$  to intersect with the horizontal line projected from point C. Repeat this procedure.
6. Commencing at point A, join the above intersections to form the required cycloid.

## The epicycloid

An epicycloid is defined as the locus of a point on the circumference of a circle which rolls without slip around the outside of another circle. The method of construction is shown in Fig. 12.15.



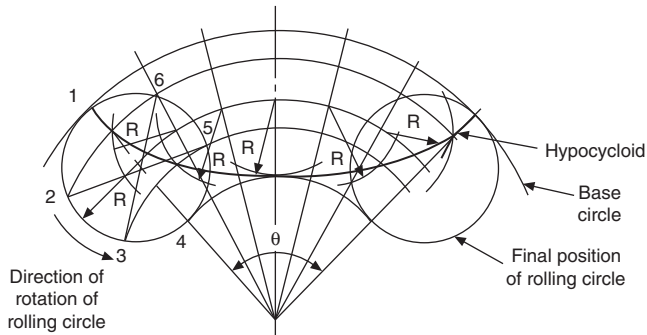
**Fig. 12.15** Epicycloid.

1. Draw the curved surface and the rolling circle, and divide the circle into a convenient number of parts (say six) and number them as shown.
2. Calculate the length of the circumference of the smaller and the larger circle, and from this information calculate the angle  $\theta$  covered by the rolling circle.
3. Divide the angle  $\theta$  into the same number of parts as in the rolling circle.
4. Draw the arc which is the locus of the center of the rolling circle.
5. The lines forming the angles in step 3 will now intersect with the arc in step 4 to give six further positions of the centers of the rolling circle as it rotates.
6. From the second center, draw radius  $R$  to intersect with the arc from point 2 on the rolling circle. Repeat this process for points 3, 4, 5, and 6.
7. Draw a smooth curve through the points of intersection, to give the required epicycloid.

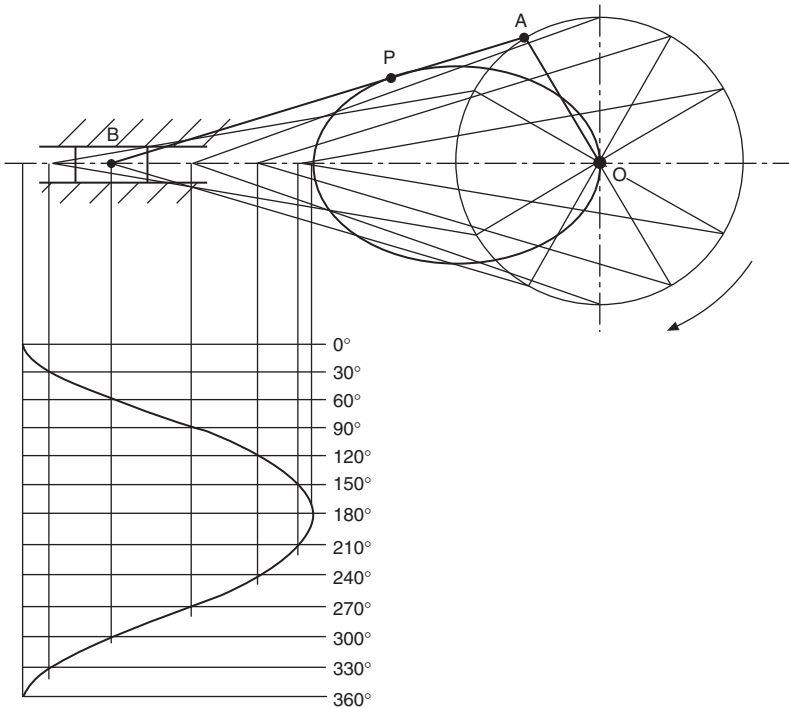
## The hypocycloid

A hypocycloid is defined as the locus of a point on the circumference of a circle which rolls without slip around the inside of another circle.

The construction for the hypocycloid (Fig. 12.16) is very similar to that for the epicycloid, but note that the rolling circle rotates in the opposite direction for this construction.



**Fig. 12.16** Hypocycloid.



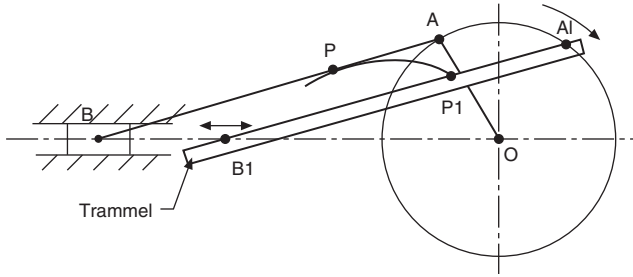
**Fig. 12.17** Locus at point P on a crank, con rod and piston with piston displacement diagram.

It is often necessary to study the paths taken by parts of oscillating, reciprocating, or rotating mechanisms; from a knowledge of displacement and time, information regarding velocity and acceleration can be obtained. It may also be required to study the extreme movements of linkages, so that safety guards can be designed to protect machine operators.

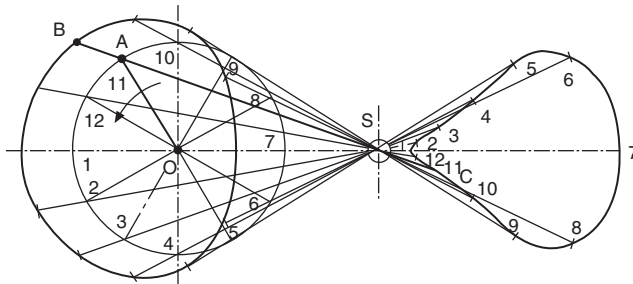
**Fig. 12.17** shows a crank OA, a connecting rod AB, and a piston B which slides along the horizontal axis BO. P is any point along the connecting rod. To plot the locus of point P, a circle of radius OA has been divided into 12 equal parts. From each position of the crank, the connecting rod is drawn, distance AP measured, and the path taken for one revolution lined in as indicated.

The drawing also shows the piston-displacement diagram. A convenient vertical scale is drawn for the crank angle and in this case clockwise rotation was assumed to start from the 9 o'clock position. From each position of the piston, a vertical line is drawn down to the corresponding crank-angle line, and the points of intersection are joined to give the piston-displacement diagram.

The locus of the point P can also be plotted by the trammel method indicated in **Fig. 12.18**. Point  $P_1$  can be marked for any position where  $B_1$  lies on the horizontal line, provided  $A_1$  also lies on the circumference of the circle radius OA. This method of solving some loci problems has the advantage that an infinite number of points can



**Fig. 12.18** Locus at point P using the trammel method.



**Fig. 12.19** Loci at points B and C on a rotating crank.

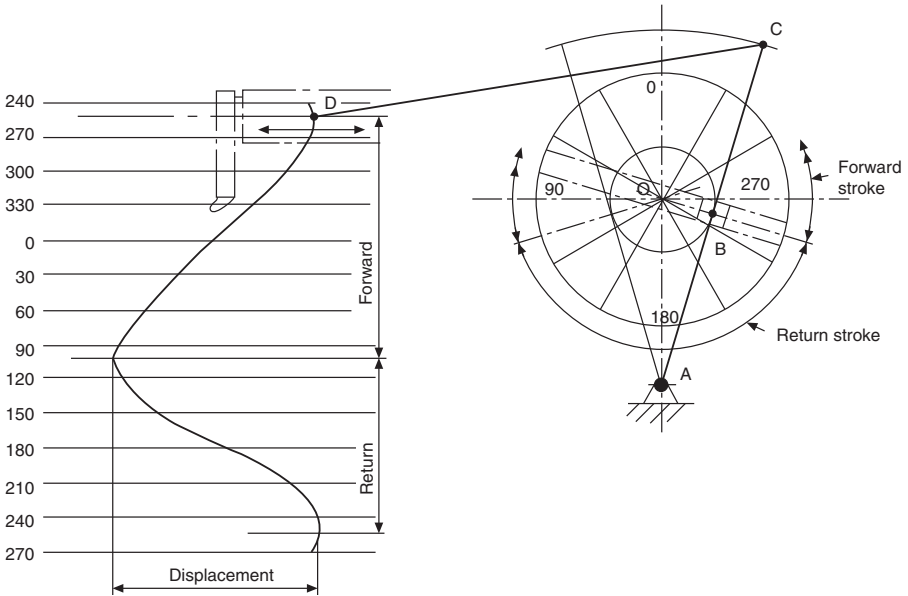
easily be obtained, and these are especially useful where a change in direction in the loci curve takes place.

Fig. 12.19 shows a crank OA rotating anticlockwise about center O. A rod BC is connected to the crank at point A, and this rod slides freely through a block which is allowed to pivot at point S. The loci of points B and C are indicated after reproducing the mechanism in 12 different positions. A trammel method could also be used here if required.

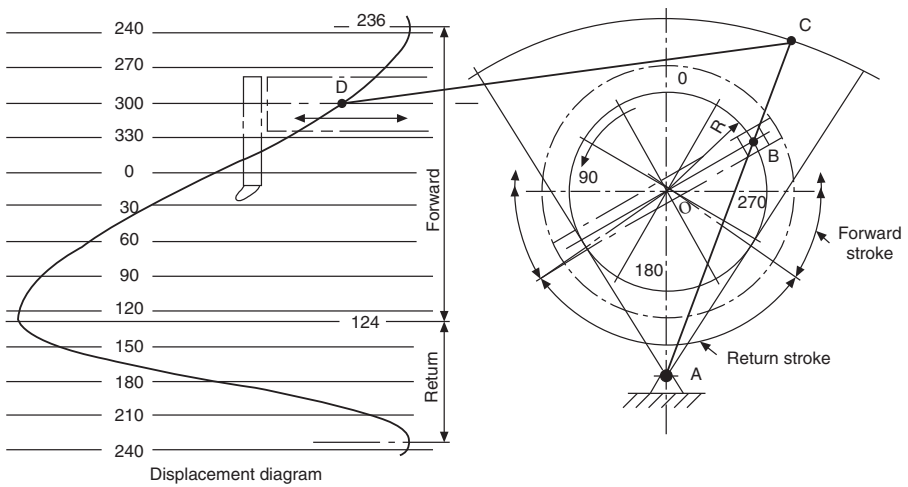
Part of a shaping-machine mechanism is given in Fig. 12.20. Crank OB rotates about center O. A is a fixed pivot point, and CA slides through the pivoting block at B. Point C moves in a circular arc of radius AC, and is connected by link CD, where point D slides horizontally. In the position shown, angle OBA is  $90^\circ$ , and if OB now rotates anticlockwise at constant speed it will be seen that the forward motion of point D takes more time than the return motion. A displacement diagram for point D has been constructed as previously described.

In Fig. 12.21 the radius OB has been increased, with the effect of increasing the stroke of point D. Note also that the return stroke in this condition is quicker than before.

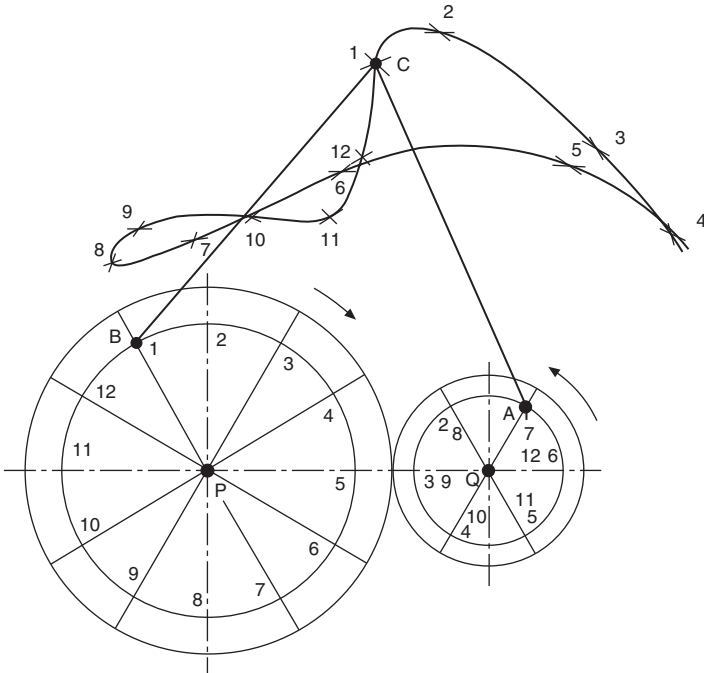
The outlines of two gears are shown in Fig. 12.22, where the pitch circle of the larger gear is twice the pitch circle of the smaller gear. As a result, the smaller gear rotates twice while the larger gear rotates once. The mechanism has been drawn in 12 positions to plot the path of the pivot point C, where links BC and CA are connected. A trammel method cannot be applied successfully in this type of problem.



**Fig. 12.20** Movement of point D on a mechanism with a displacement diagram.

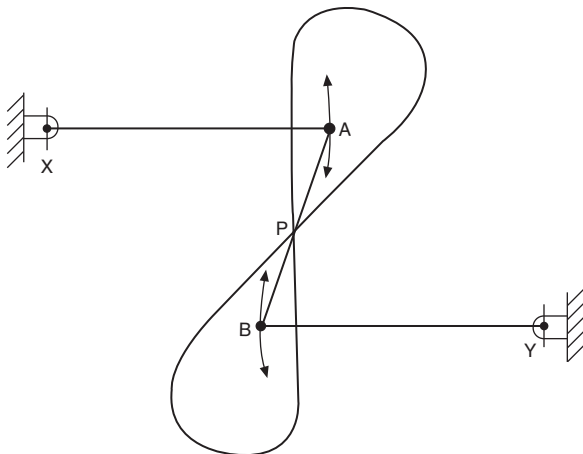


**Fig. 12.21** Movement of point D with increased radius on a mechanism with a displacement diagram.

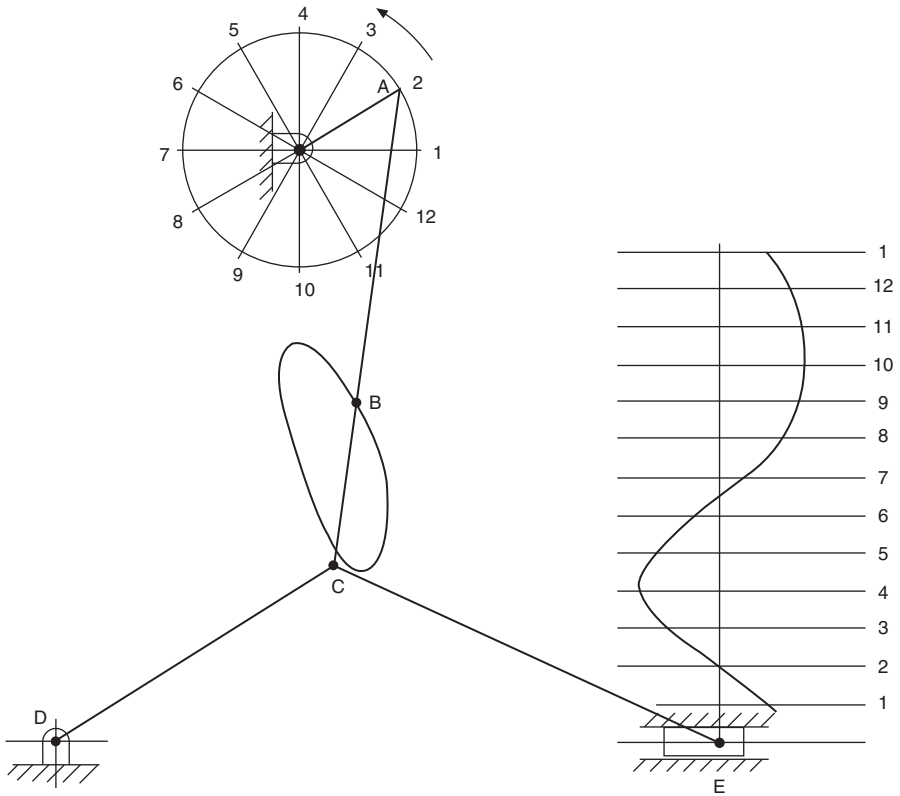


**Fig. 12.22** Plot of point C with links BC and CA connected.

**Fig. 12.23** gives an example of Watt’s straight-line motion. Two levers AX and BY are connected by a link AB, and the plotted curve is the locus of the mid-point P. The levers in this instance oscillate in circular arcs. This mechanism was used in engines designed by James Watt, the famous engineer.



**Fig. 12.23** Watt’s straight-line motion.



**Fig. 12.24** Toggle action and displacement diagram.

A toggle action is illustrated in Fig. 12.24, where a crank rotates anticlockwise. Links AC, CD, and CE are pivoted at C. D is a fixed pivot point, and E slides along the horizontal axis. The displacement diagram has been plotted as previously described, but note that, as the mechanism at E slides to the right, it is virtually stationary between points 9, 10, and 11.

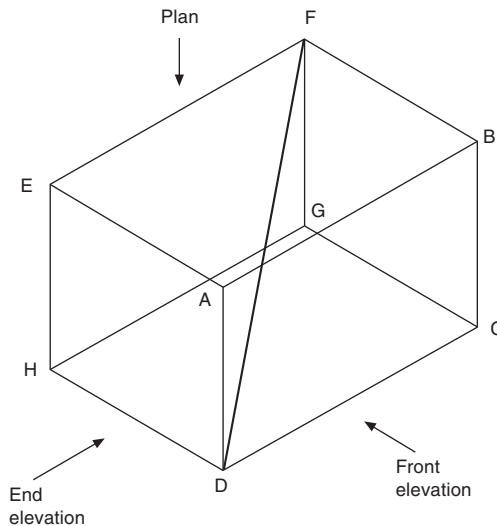
The locus of any point B is also shown.

# True lengths and auxiliary views

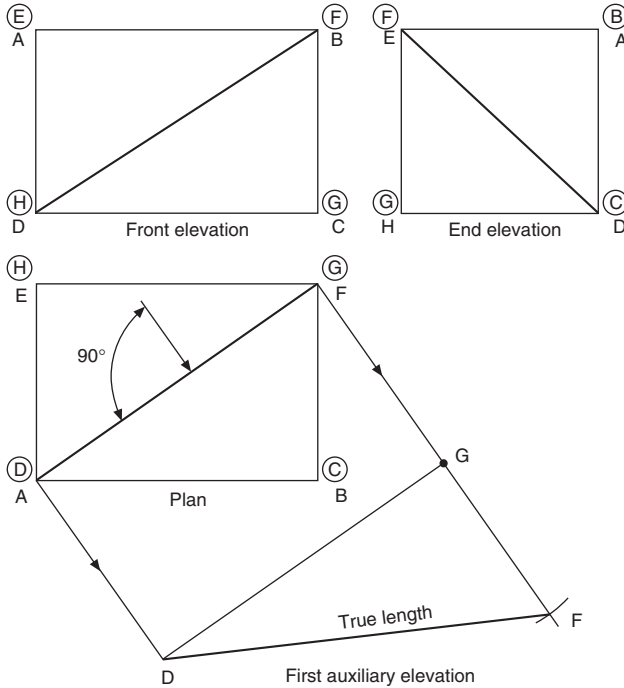
# 13

An isometric view of a rectangular block is shown in Fig. 13.1. The corners of the block are used to position a line DF in space. Three orthographic views in first-angle projection are given in Fig. 13.2, and it will be apparent that the projected length of the line DF in each of the views will be equal in length to the diagonals across each of the rectangular faces. A cross check with the isometric view will clearly show that the true length of line DF must be greater than any of the diagonals in the three orthographic views. The corners nearest to the viewing position are shown as ABCD etc.; the corners on the remote side are indicated in rings. To find the true length of DF, an auxiliary projection must be drawn, and the viewing position must be square with line DF. The first auxiliary projection in Fig. 13.2 gives the true length required, and forms part of the right-angled triangle DFG. Note that auxiliary views are drawn on planes other than the principal projection planes. A plan is projected from an elevation and an elevation from a plan. Since this is the first auxiliary view projected, and from a true plan, it is known as a *first auxiliary elevation*. Other auxiliary views could be projected from this auxiliary elevation if so required.

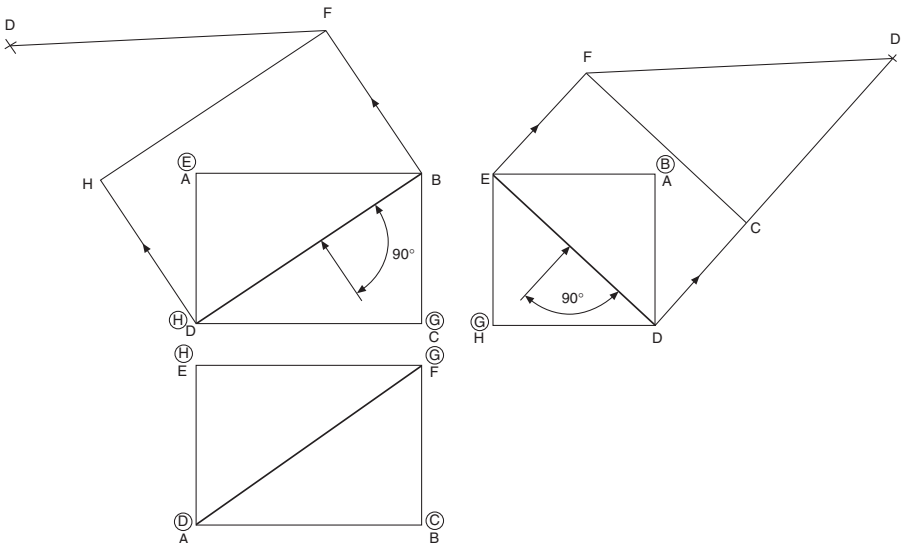
The true length of DF could also have been obtained by projection from the front or end elevations by viewing at  $90^\circ$  to the line, and Fig. 13.3 shows these two alternatives. The first auxiliary plan from the front elevation gives triangle FDH, and the first auxiliary plan from the end elevation gives triangle FCD, both right-angled triangles.



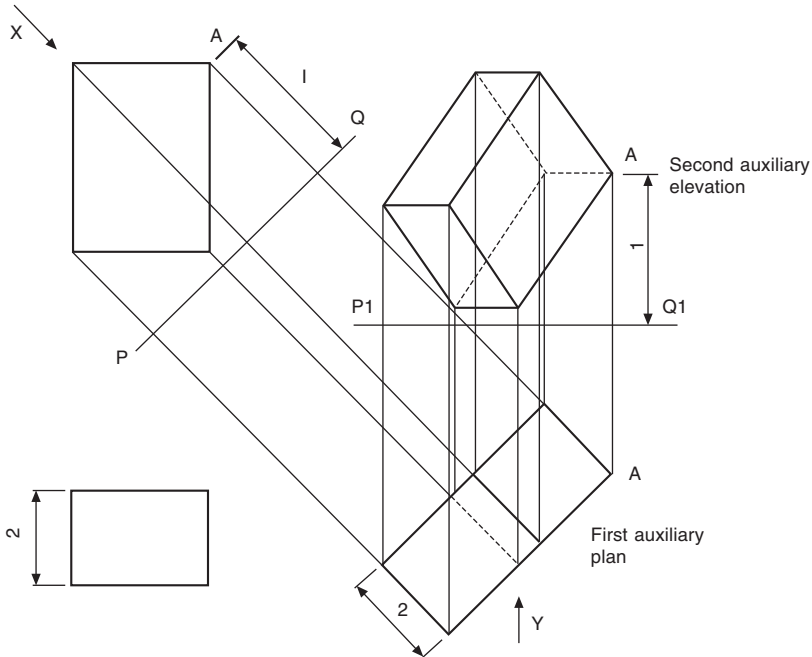
**Fig. 13.1** Isometric view of a rectangular block showing the line DF across corners.



**Fig. 13.2** Orthographic views in first angle projection of a rectangular block with projected line DF.



**Fig. 13.3** Alternative projection of line DF.



**Fig. 13.4** First and second auxiliary projection taken from front elevation.

Fig. 13.4 shows the front elevation and plan view of a box. A first auxiliary plan is drawn in the direction of arrow X. Now PQ is an imaginary datum plane at right angles to the direction of viewing; the perpendicular distance from corner A to the plane is shown as dimension 1. When the first auxiliary plan view is drawn, the box is in effect turned through  $90^\circ$  in the direction of arrow X, and the corner A will be situated above the plane at a perpendicular distance equal to dimension 1. The auxiliary plan view is a true view on the tilted box. If a view is now taken in the direction of arrow Y, the tilted box will be turned through  $90^\circ$  in the direction of the arrow, and dimension 1 to the corner will lie parallel with the plane of the paper. The other seven corners of the box are projected as indicated, and are positioned by the dimensions to the plane PQ in the front elevation. A match-box can be used here as a model to appreciate the position in space for each projection.

The same box has been redrawn in Fig. 13.5, but the first auxiliary elevation has been taken from the plan view in a manner similar to that described in the previous example. The second auxiliary plan projected in line with arrow Y requires dimensions from plane P1Q1, which are taken as before from plane PQ. Again, check the projections shown with a match-box. All of the following examples use the principles demonstrated in these two problems.

Part of a square pyramid is shown in Fig. 13.6; the constructions for the eight corners in both auxiliary views are identical with those described for the box in Fig. 13.4.

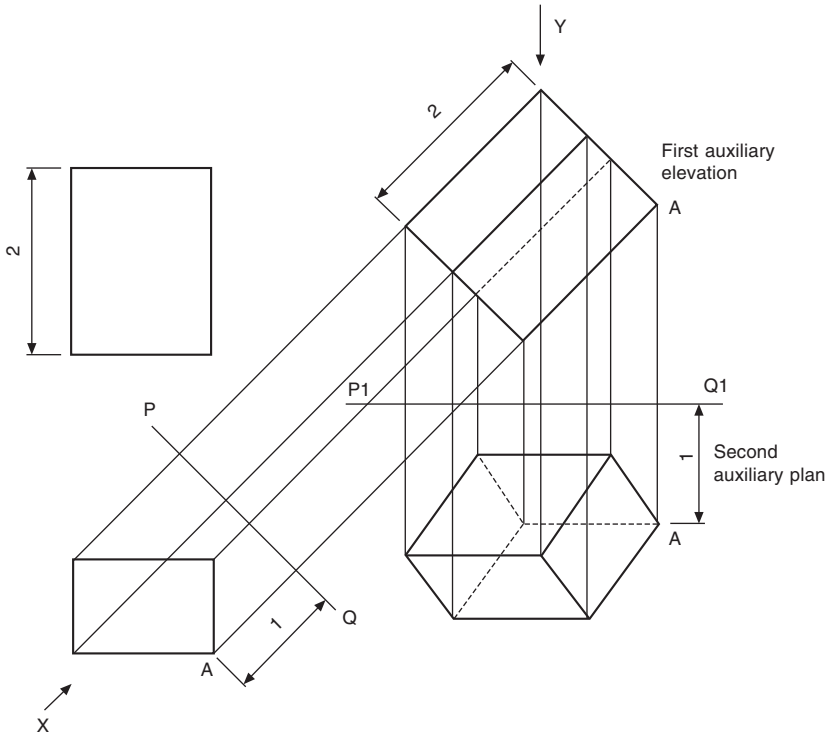


Fig. 13.5 First and second auxiliary projection taken from plan view.

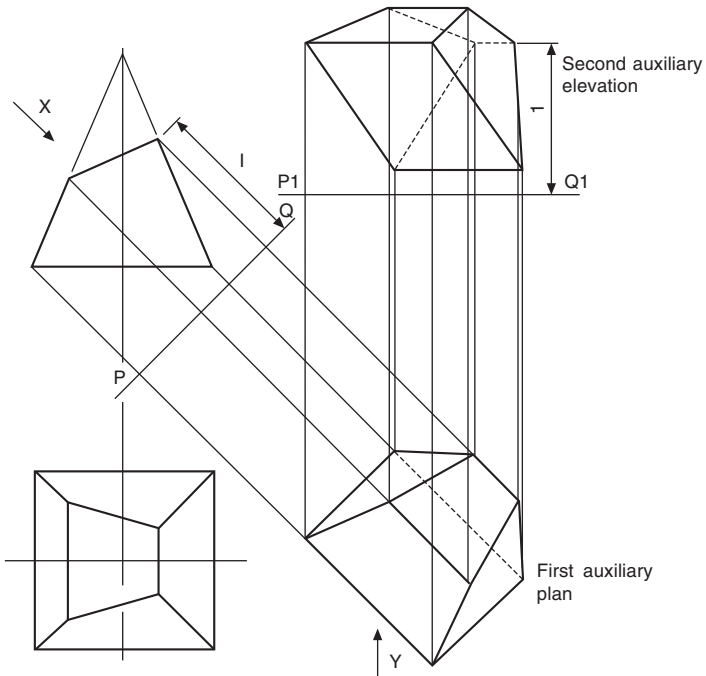
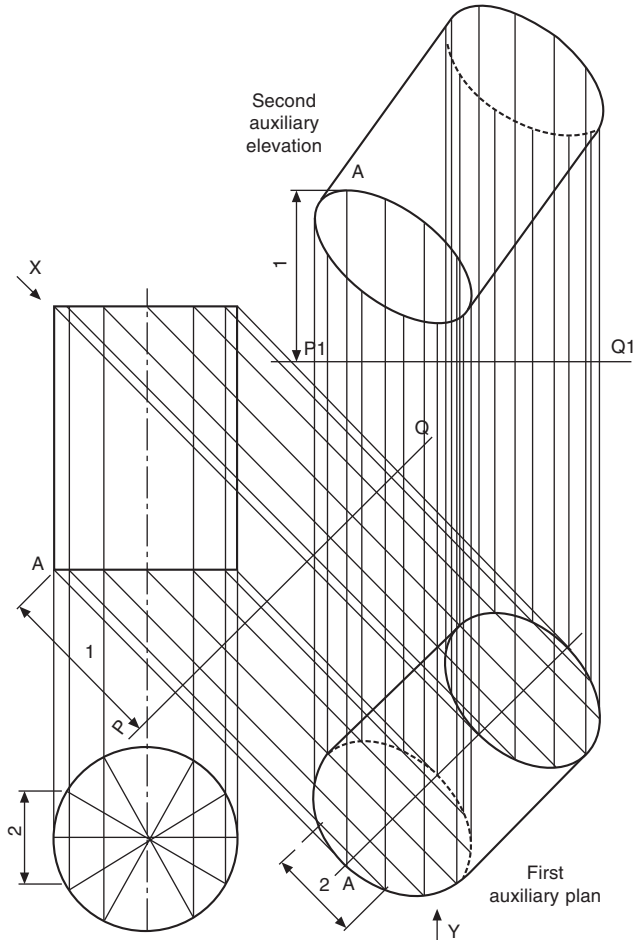


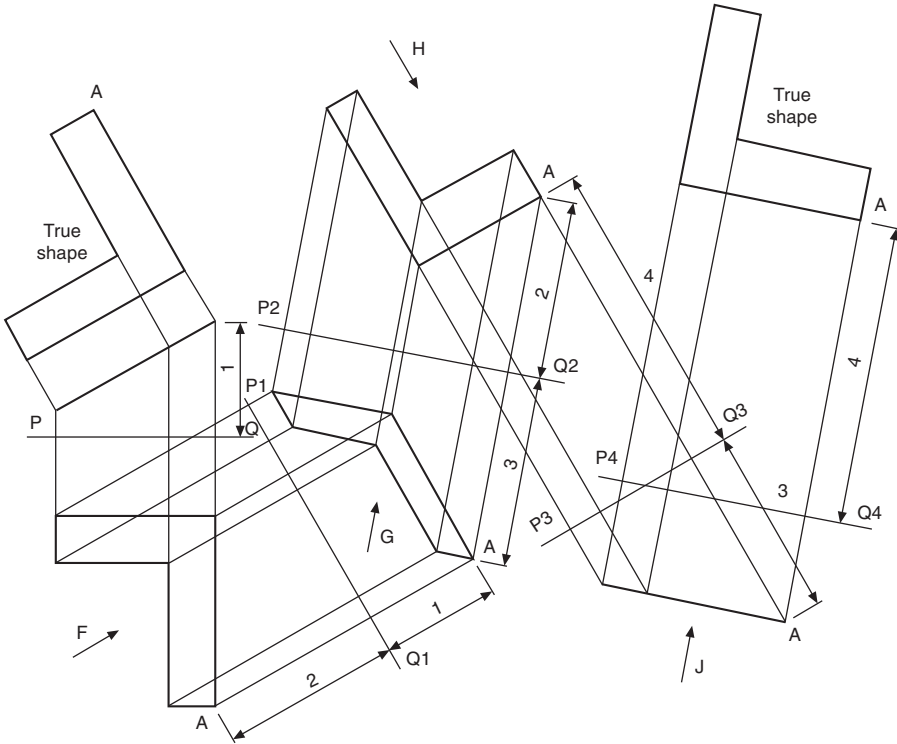
Fig. 13.6 First and second auxiliary projection of the corners of a partial square.



**Fig. 13.7** First and second auxiliary projection of a cylinder.

Auxiliary projections from a cylinder are shown in Fig. 13.7; note that chordal widths in the first auxiliary plan are taken from the true plan. Each of 12 points around the circle is plotted in this way and then projected up to the auxiliary elevation. Distances from plane PQ are used from plane P1 Q1. Auxiliary projections of any irregular curve can be made by plotting the positions of a succession of points from the true view and rejoining them with a curve in the auxiliary view.

Fig. 13.8 shows a front elevation and plan view of a thin lamina in the shape of the letter L. The lamina lies inclined above the datum plane PQ, and the front elevation appears as a straight line. The true shape is projected above as a first auxiliary view. From the given plan view, an auxiliary elevation has been projected in line with the arrow F, and the positions of the corners above the datum plane P1 Q1 will be the same as those above the original plane PQ. A typical dimension to the corner A has been added as dimension 1. To assist in comprehension, the true shape given could

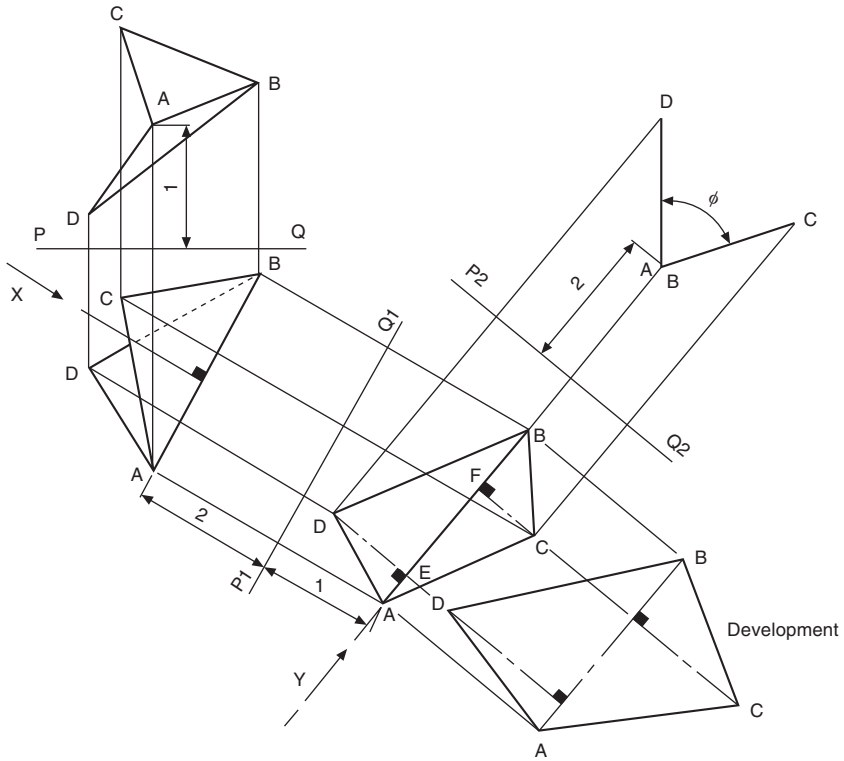


**Fig. 13.8** True shape projections of a lamina.

be cut from a piece of paper and positioned above the book to appreciate how the lamina is situated in space; it will then be seen that the height above the book of corner A will be dimension 2.

Now a view in the direction of arrow G parallel with the surface of the book will give the lamina shown projected above datum P2 Q2. The object of this exercise is to show that if only two auxiliary projections are given in isolation, it is possible to draw projections to find the true shape of the component and also get the component back, parallel to the plane of the paper. The view in direction of arrow H has been drawn and taken at 90° to the bottom edge containing corner A; the resulting view is the straight line of true length positioned below the datum plane P3 Q3. The lamina is situated in this view in the perpendicular position above the paper, with the lower edge parallel to the paper and at a distance equal to dimension 4 from the surface. View J is now drawn square to this projected view and positioned above the datum P4 Q4 to give the true shape of the given lamina.

In Fig. 13.9, a lamina has been made from the polygon ACBD in the development and bent along the axis AB; again, a piece of paper cut to this shape and bent to the angle  $\phi$  may be of some assistance. The given front elevation and plan position the bent lamina in space, and this exercise is given here since every line used to form



**Fig. 13.9** Development of a lamina.

the lamina in these two views is not a true length. It will be seen that, if a view is now drawn in the direction of arrow X, which is at right angles to the bend line AB, the resulting projection will give the true length of AB, and this line will also lie parallel with the plane of the paper. By looking along the fold in the direction of arrow Y, the two corners A and B will appear coincident; also, AD and BC will appear as the true lengths of the altitudes DE and FC. The development can now be drawn, since the positions of points E and F are known along the true length of AB. The lengths of the sides AD, DB, BC, and AC are obtained from the pattern development.

# Conic sections and interpenetration of solids

# 14

Consider a right circular cone, i.e. a cone whose base is a circle and whose apex is above the center of the base (Fig. 14.1).

- The true face of a section through the apex of the cone will be a triangle.
- The true face of a section drawn parallel to the base will be a circle.
- The true face of any other section which passes through two opposite generators will be an ellipse.
- The true face of a section drawn parallel to the generator will be a parabola.

If a plane cuts the cone through the generator and the base on the same side of the cone axis, then a view on the true face of the section will be a hyperbola. The special case of a section at right-angles to the base gives a rectangular hyperbola.

## To draw an ellipse from part of a cone

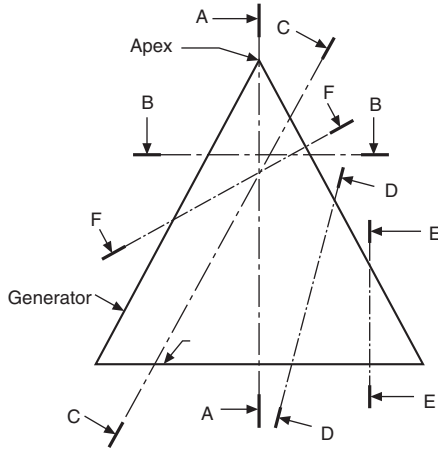
Fig. 14.2 shows the method of drawing the ellipse, which is a true view on the surface marked AB of the frustum of the given cone.

1. Draw a center line parallel to line AB as part of an auxiliary view.
2. Project points A and B onto this line and onto the center lines of the plan and end elevation.
3. Take any horizontal section XX between A and B and draw a circle in the plan view of diameter  $D$ .
4. Project the line of section plane XX onto the end elevation.
5. Project the point of intersection of line AB and plane XX onto the plan view.
6. Mark the chord-width  $W$  in the plan, in the auxiliary view and the end elevation. These points in the auxiliary view form part of the ellipse.
7. Repeat with further horizontal sections between A and B, to complete the views as shown.

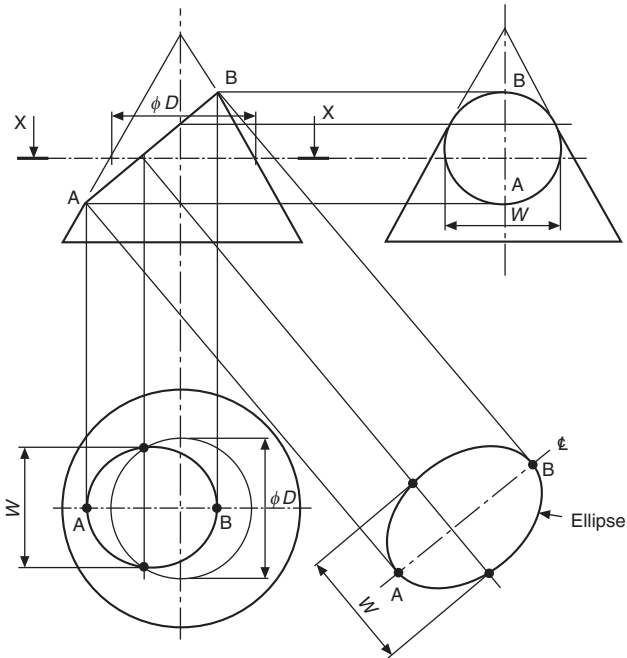
## To draw a parabola from part of a cone

Fig. 14.3 shows the method of drawing the parabola, which is a true view on the line AB drawn parallel to the sloping side of the cone.

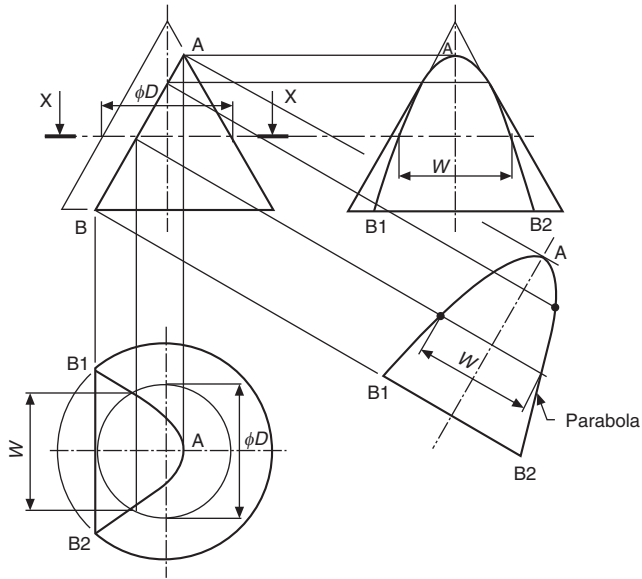
1. Draw a center line parallel to line AB as part of an auxiliary view.
2. Project point B to the circumference of the base in the plan view, to give the points B1 and B2. Mark chord-width B1 B2 in the auxiliary view and in the end elevation.
3. Project point A onto the other three views.
4. Take any horizontal section XX between A and B and draw a circle in the plan view of diameter  $D$ .



**Fig. 14.1** Conic sections: section AA, triangle; section BB, circle; section CC, parabola; section DD, hyperbola; section EE, rectangular hyperbola; section FF, ellipse.



**Fig. 14.2** Method of drawing an ellipse.



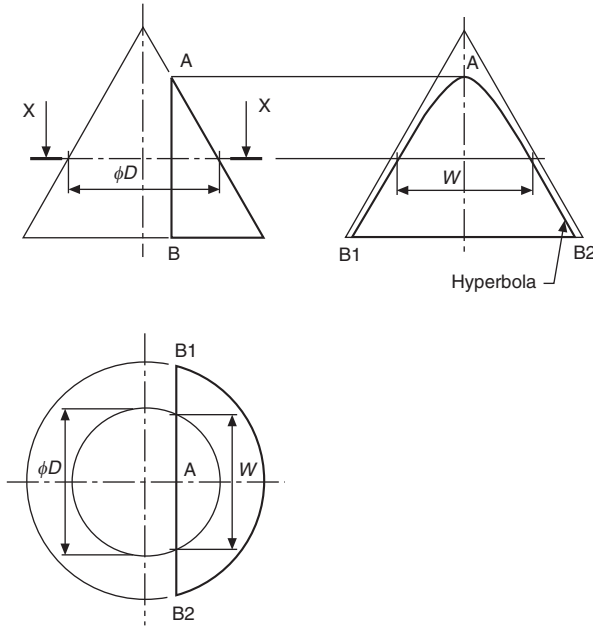
**Fig. 14.3** Method of drawing a parabola.

5. Project the line of section plane XX onto the end elevation.
6. Project the point of intersection of line AB and plane XX to the plane view.
7. Mark the chord-width  $W$  on the plan, in the end elevation and the auxiliary view. These points in the auxiliary view form part of the parabola.
8. Repeat with further horizontal sections between A and B, to complete the three views.

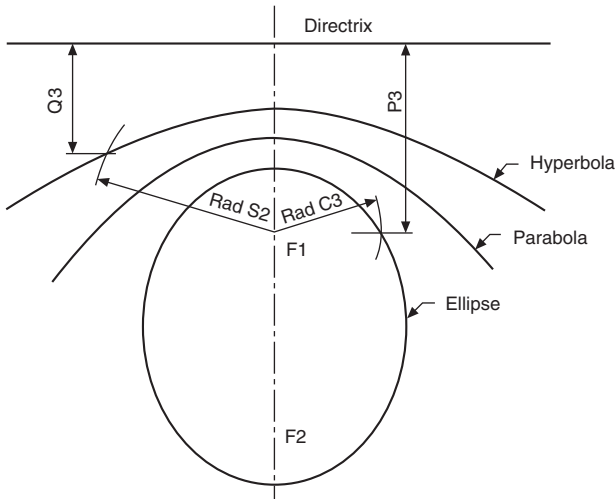
## To draw a rectangular hyperbola from part of a cone

Fig. 14.4 shows the method of drawing the hyperbola, which is a true view on the line AB drawn parallel to the vertical center line of the cone.

1. Project point B to the circumference of the base in the plan view, to give the points B and B.
2. Mark points B1 and B2 in the end elevation.
3. Project point A onto the end elevation. Point A lies on the center line in the plan view.
4. Take any horizontal section XX between A and B and draw a circle of diameter  $D$  in the plan view.
5. Project the line of section XX onto the end elevation.
6. Mark the chord-width  $W$  in the plan, on the end elevation. These points in the end elevation form part of the hyperbola.
7. Repeat with further horizontal sections between A and B, to complete the hyperbola.
8. The ellipse, parabola, and hyperbola are also the loci of points which move in fixed ratios from a line (the directrix) and a point (the focus). The ratio is known as the *eccentricity*.

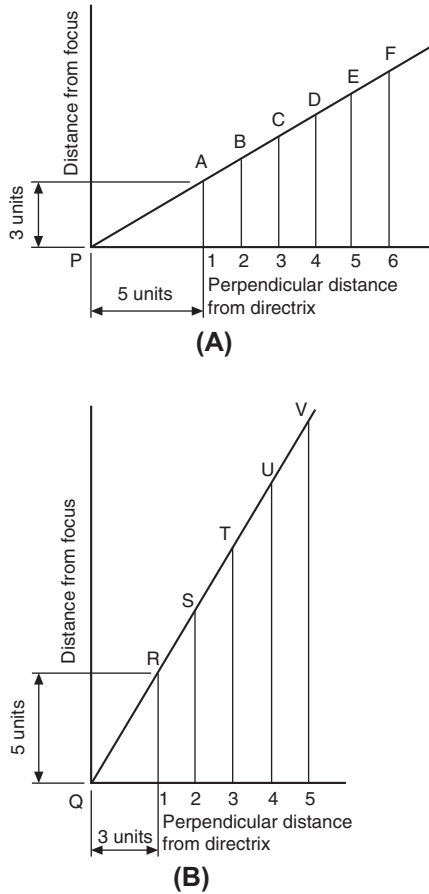


**Fig. 14.4** Method of drawing a hyperbola.



**Fig. 14.5** Eccentric ellipse, parabola and hyperbola.

Fig. 14.5 shows an ellipse of eccentricity  $3/5$ , a parabola of eccentricity  $1$ , and a hyperbola of eccentricity  $5/3$ . The distances from the focus are all radial, and the distances from the directrix are perpendicular, as shown by the illustration.



**Fig. 14.6** (A) Ellipse construction. (B) Hyperbola construction.

To assist in the construction of the ellipse in Fig. 14.5, the following method may be used to ensure that the two dimensions from the focus and directrix are in the same ratio. Draw triangle PA1 so that side A1 and side P1 are in the ratio of 3–5 units. Extend both sides as shown. From any points B, C, D, etc., draw vertical lines to meet the horizontal at 2, 3, 4, etc.; by similar triangles, vertical lines and their corresponding horizontal lines will be in the same ratio. A similar construction for the hyperbola is shown in Fig. 14.6.

Commence the construction for the ellipse by drawing a line parallel to the directrix at a perpendicular distance of P3 (Fig. 14.6 (a)). Draw radius C3 from point F1 to intersect this line. The point of intersection lies on the ellipse. Similarly, for the hyperbola (Fig. 14.6 (b)) draw a line parallel to the directrix at a perpendicular distance of Q2. Draw radius S2, and the hyperbola passes through the point of intersection. No scale is required for the parabola, as the perpendicular distances and the radii are the same magnitude.

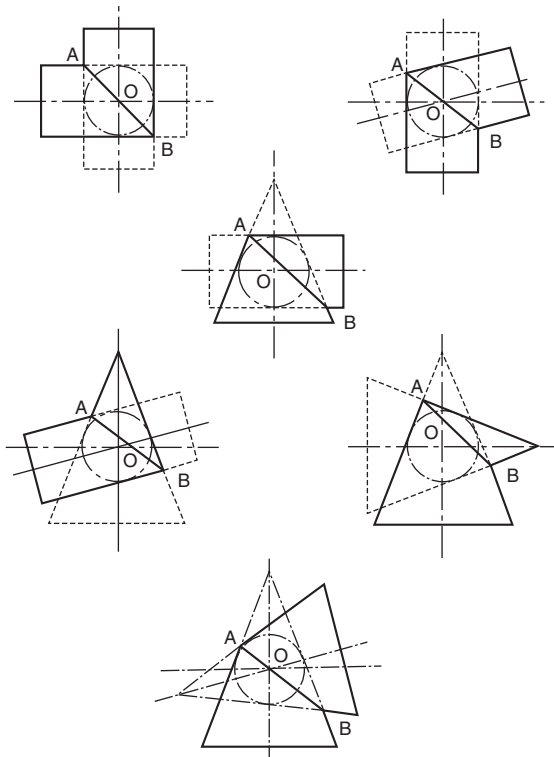
Repeat the procedure in each case to obtain the required curves.

## Interpenetration

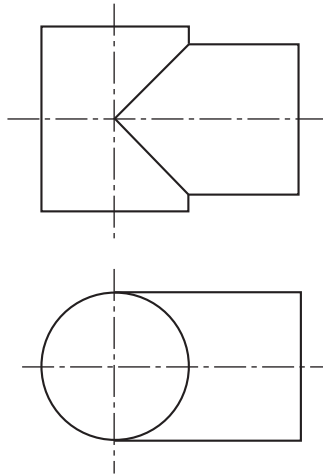
Many objects are formed by a collection of geometrical shapes such as cubes, cones, spheres, cylinders, prisms, and pyramids., and where any two of these shapes meet, some sort of curve of intersection or interpenetration results. It is necessary to be able to draw these curves to complete drawings in orthographic projection or to draw patterns and developments.

The following drawings show some of the most commonly found examples of interpenetration. Basically, most curves are constructed by taking sections through the intersecting shapes, and, to keep construction lines to a minimum and hence avoid confusion, only one or two sections have been taken in arbitrary positions to show the principle involved; further similar parallel sections are then required to establish the line of the curve in its complete form. Where center lines are offset, hidden curves will not be the same as curves directly facing the designer, but the draughting principle of taking sections in the manner indicated on either side of the center lines of the shapes involved will certainly be the same.

If two cylinders, or a cone and a cylinder, or two cones intersect each other at any angle, and the curved surfaces of both solids enclose the same sphere, then the outline of the intersection in each case will be an ellipse. In the illustrations given in [Fig. 14.7](#) the center lines of the two solids intersect at point O, and a true view along the line AB will produce an ellipse.



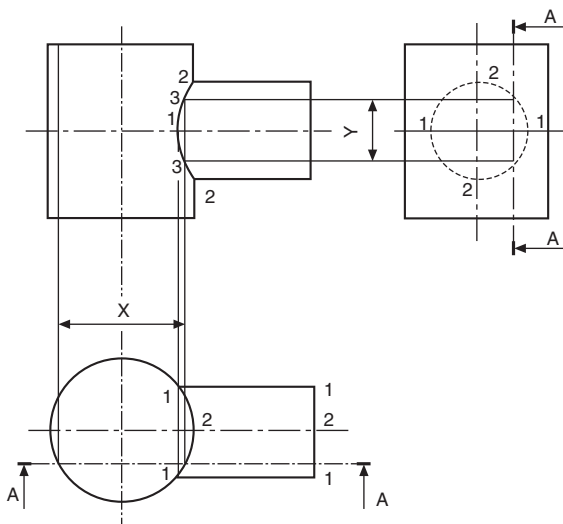
**Fig. 14.7** Elliptical intersections.



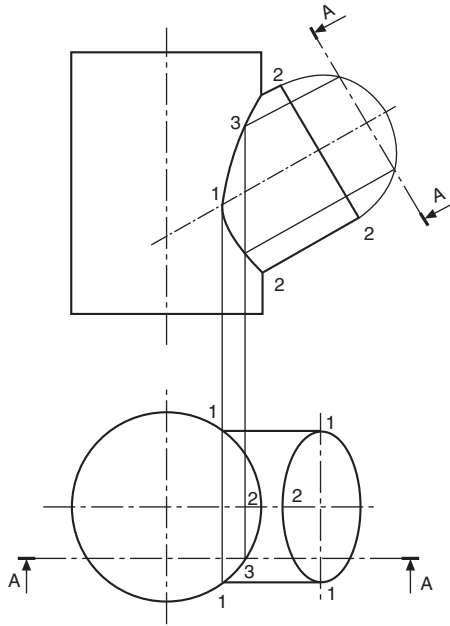
**Fig. 14.8** Straight line intersection.

When cylinders of equal diameter intersect as shown in Fig. 14.8 the line at the intersection is straight and at  $45^\circ$ .

Fig. 14.9 shows a branch cylinder square with the axis of the vertical cylinder but reduced in size. A section through any cylinder parallel with the axis produces a rectangle, in this case of width  $Y$  in the branch and width  $X$  in the vertical cylinder. Note that interpenetration occurs at points marked 3, and these points lie on a curve. The projection of the branch cylinder along the horizontal center line gives the points marked 1, and along the vertical center line gives the points marked 2.



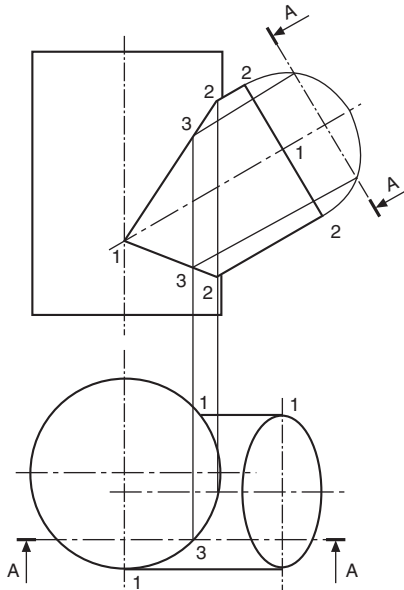
**Fig. 14.9** Intersection of differing diameters.



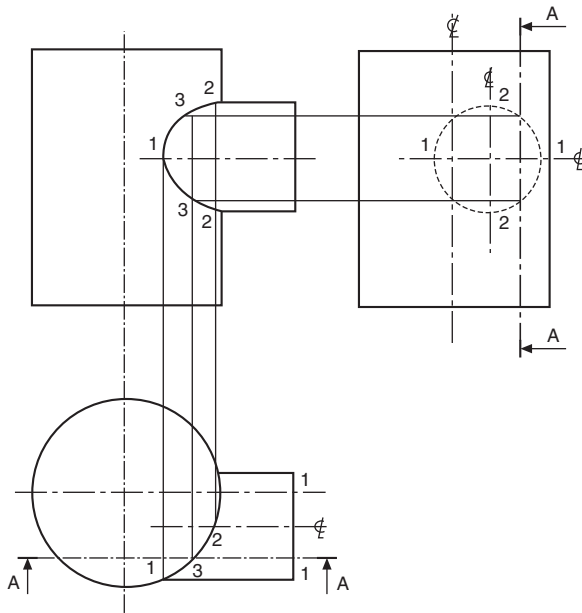
**Fig. 14.10** Intersection of inclined differing diameters.

Fig. 14.10 shows a cylinder with a branch on the same vertical center line but inclined at an angle. Instead of an end elevation, the position of section AA is shown on a part auxiliary view of the branch. The construction is otherwise the same as that for Fig. 14.9.

In Fig. 14.11 the branch is offset, but the construction is similar to that shown in Fig. 14.10.



**Fig. 14.11** Intersection of offset inclined differing diameters.

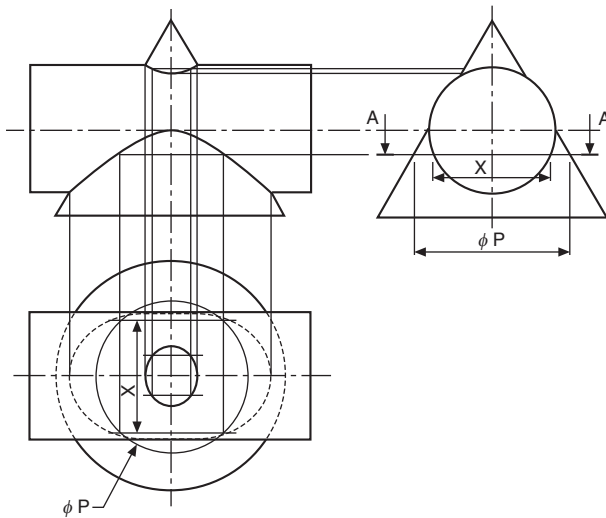


**Fig. 14.12** Intersection of offset square differing diameters.

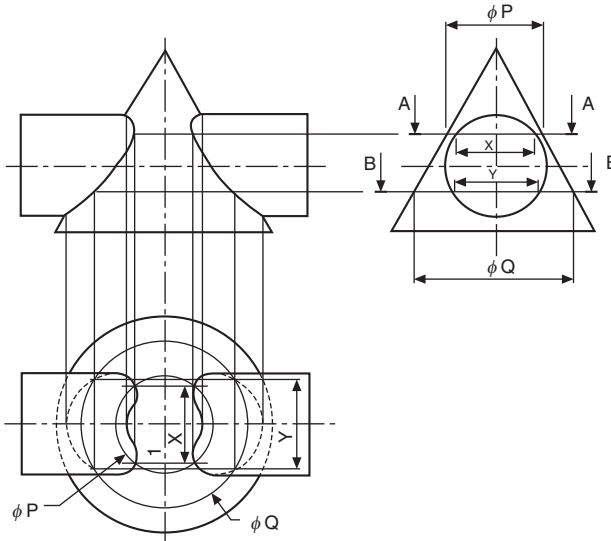
Fig. 14.12 shows the branch offset but square with the vertical axis.

Fig. 14.13 shows a cone passing through a cylinder. A horizontal section AA through the cone will give a circle of  $\phi P$ , and through the cylinder will give a rectangle of width  $X$ . The points of intersection of the circle and part of the rectangle in the plan view are projected up to the section plane in the front elevation.

The plotting of more points from more sections will give the interpenetration curves shown in the front elevation and the plan.



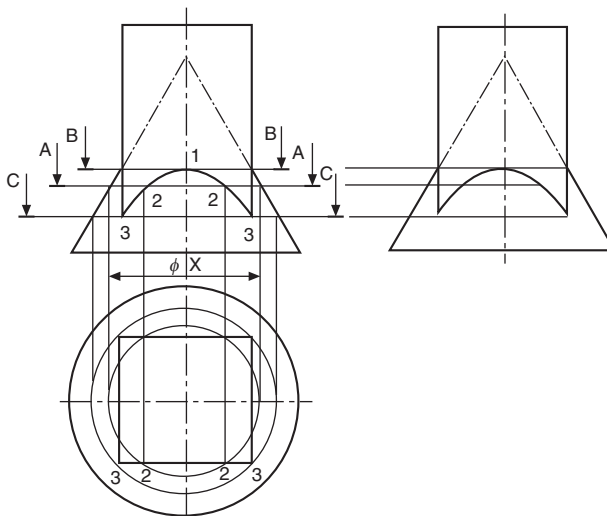
**Fig. 14.13** Intersection of a cone passing through a cylinder.



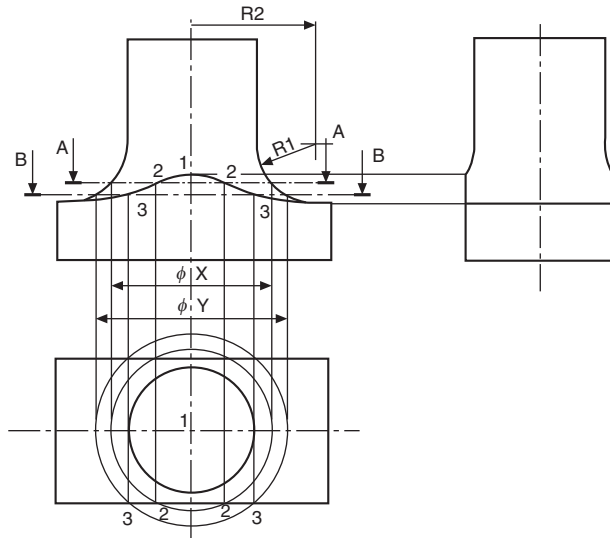
**Fig. 14.14** Intersection of a cylinder passing through a cone.

Fig. 14.14 shows a cylinder passing through a cone. The construction shown is the same as for Fig. 14.13 in principle.

Fig. 14.15 shows a cone and a square prism where interpenetration starts along the horizontal section BB at point 1 on the smallest diameter circle to touch the prism. Section AA is an arbitrary section where the projected diameter of the cone  $\phi X$  cuts the prism in the plan view at the points marked 2. These points are then projected back to the section plane in the front elevation and lie on the curve required. The circle at section CC is the largest circle which will touch the prism across the diagonals in the plan view.



**Fig. 14.15** Intersection of a cone and square prism.

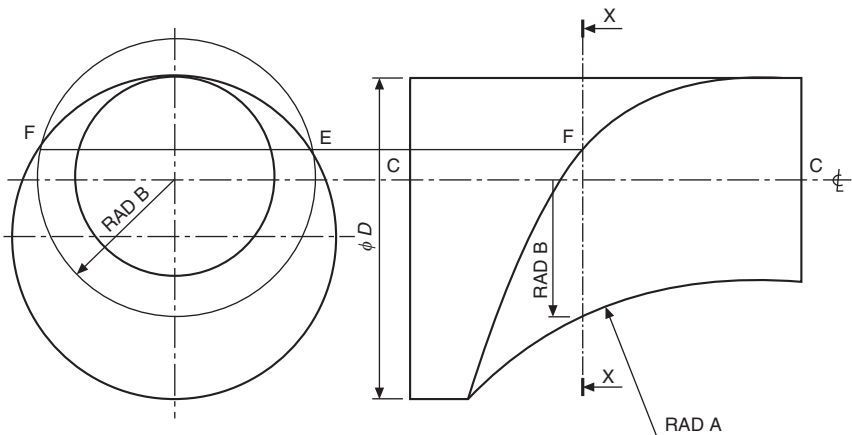


**Fig. 14.16** Intersection of a rectangular and circular sections.

Having drawn the circle in the plan view, it is projected up to the sides of the cone in the front elevation, and points 3 at the corners of the prism are the lowest points of contact.

A casting with a rectangular base and a circular-section shaft is given in Fig. 14.16. The machining of the radius  $R1$  in conjunction with the milling of the flat surfaces produces the curve shown in the front elevation. Point 1 is shown projected from the end elevation. Section AA produces a circle of  $\phi X$  in the plan view and cuts the face of the casting at points marked 2, which are transferred back to the section plane. Similarly, Section BB gives  $\phi Y$  and points marked 3. Sections can be taken until the circle in the plane view increases in size to  $R2$ ; at this point, the interpenetration curve joins a horizontal line to the corner of the casting in the front elevation.

In Fig. 14.17 a circular bar of diameter  $D$  has been turned about the center line CC and machined with a radius shown as RAD A. The resulting interpenetration curve is



**Fig. 14.17** Intersection of a cylinder and a radius.

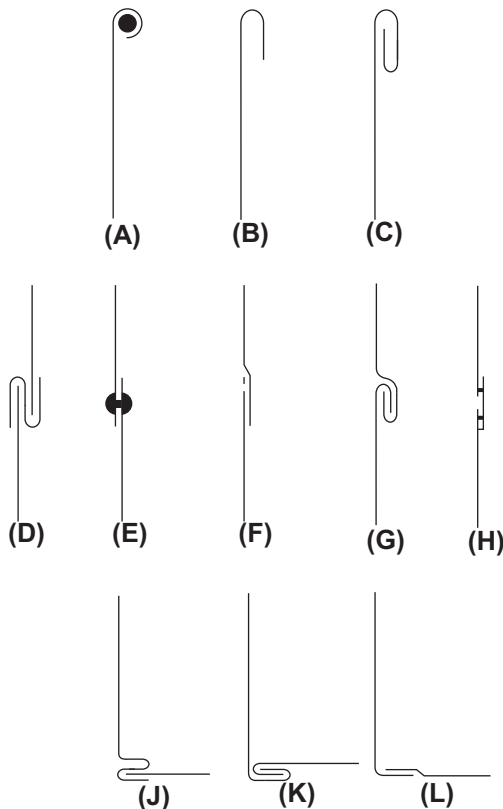
obtained by taking sections similar to section XX. At this section plane, a circle of radius B is projected in the front elevation and cuts the circumference of the bar at points E and F. The projection of point F along the section plane XX is one point on the curve. By taking a succession of sections, and repeating the process described, the curve can be plotted.

Note that, in all these types of problem, it rarely helps to take dozens of sections and then draw all the circles before plotting the points, as the usual result is confusion. It is recommended that one section be taken at a time, the first roughly near the center of any curve, and others sufficiently far apart for clarity but near enough to maintain accuracy. More sections are generally required where curves suddenly change direction.

# Development of patterns from sheet materials

Many articles such as cans, pipes, elbows, boxes, ducting, and hoppers are manufactured from thin sheet materials. Generally, a template is produced from an orthographic drawing when small quantities are required (larger quantities may justify the use of press tools), and the template will include allowances for bending and seams, bearing in mind the thickness of material used.

Exposed edges which might be dangerous can be wired or folded, and these processes also give added strength, e.g. cooking tins and pans. Some cooking tins are also formed by pressing hollows into a flat sheet. This type of deformation is not considered in this chapter, which deals with bending or forming in one plane only. Some common methods of finishing edges, seams, and corners are shown in Fig. 15.1.



**Fig. 15.1** Examples of finishing edges, seams and corners.

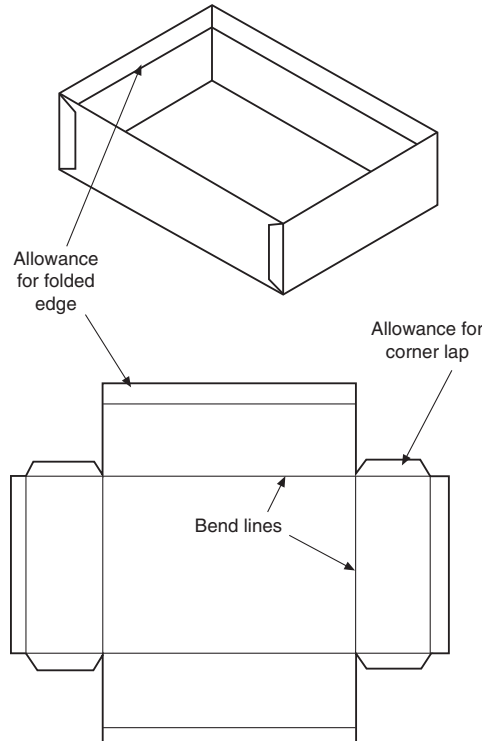
The following examples illustrate some of the more commonly used methods of development in pattern-making, but note that, apart from in the first case, no allowance has been made for joints and seams.

Where a component has its surfaces on flat planes of projection, and all the sides and corners shown are true lengths, the pattern is obtained by parallel-line or straight-line development. A simple application is given in Fig. 15.2 for an open box.

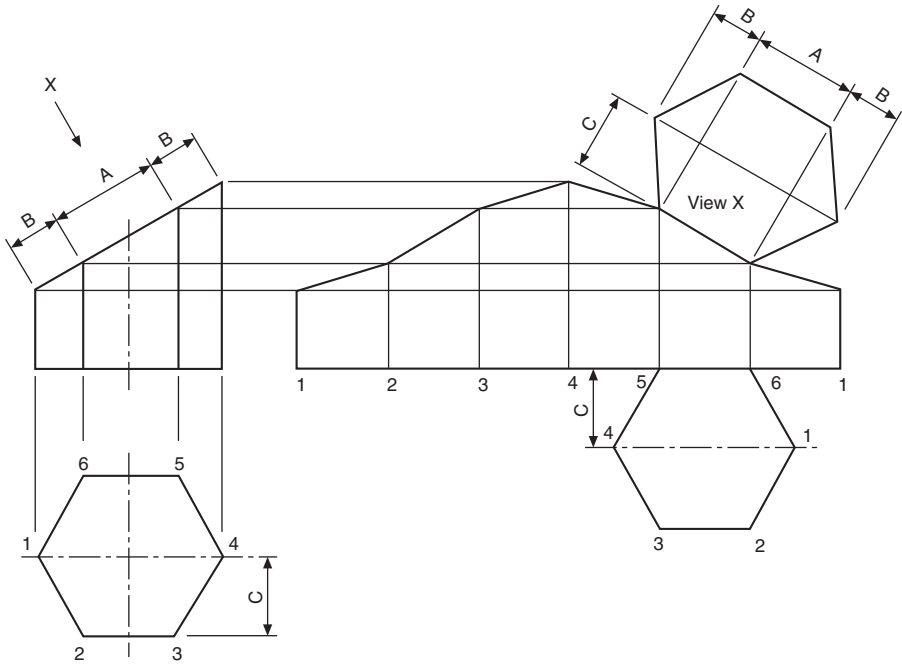
The development of a hexagonal prism is shown in Fig. 15.3. The pattern length is obtained by plotting the distances across the flat faces. The height at each corner is projected from the front elevation, and the top of the prism is drawn from a true view in the direction of arrow X.

An elbow joint is shown developed in Fig. 15.4. The length of the circumference has been calculated and divided into 12 equal parts. A part plan, divided into six parts, has the division lines projected up to the joint, then across to the appropriate point on the pattern. It is normal practice on a development drawing to leave the joint along the shortest edge; however, on part B the pattern can be cut more economically if the joint on this half is turned through  $180^\circ$ .

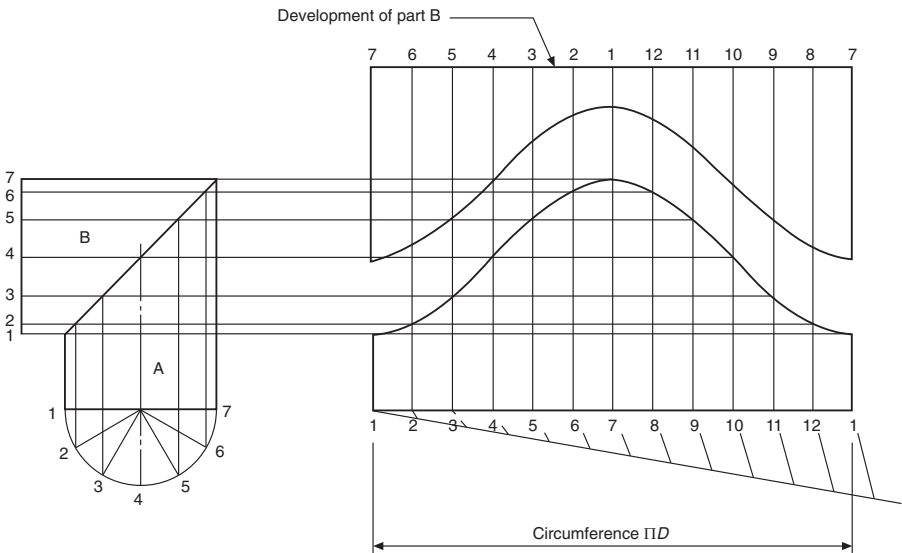
An elbow joint made from four parts has been completely developed in Fig. 15.5. Again, by alternating the position of the seams, the patterns can be cut with no waste. Note that the center lines of the parts marked B and C are  $30^\circ$  apart, and that the inner and outer edges are tangential to the radii which position the elbow.



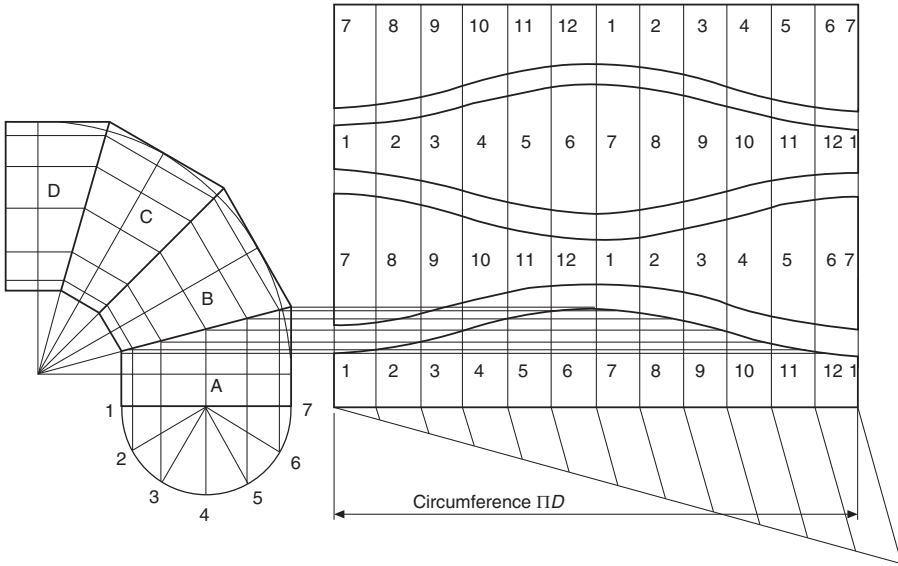
**Fig. 15.2** Development of an open box.



**Fig. 15.3** Development of hexagonal prism.



**Fig. 15.4** Development of a two part elbow joint.

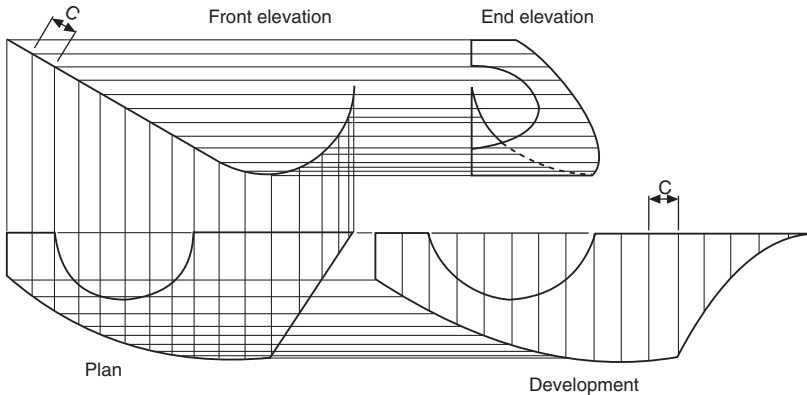


**Fig. 15.5** Development of a four part elbow joint.

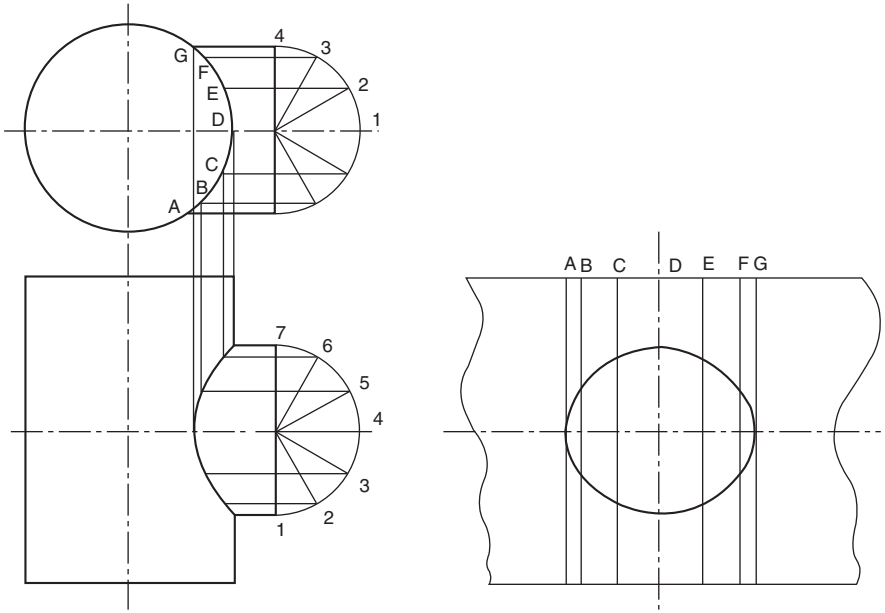
A thin lamina is shown in orthographic projection in Fig. 15.6. The development has been drawn in line with the plan view by taking the length along the front elevation in small increments of width  $C$  and plotting the corresponding depths from the plan.

A typical interpenetration curve is given in Fig. 15.7. The development of part of the cylindrical portion is shown viewed from the inside. The chordal distances on the inverted plan have been plotted on either side of the center line of the hole, and the corresponding heights have been projected from the front elevation. The method of drawing a pattern for the branch is identical to that shown for the two-piece elbow in Fig. 15.4.

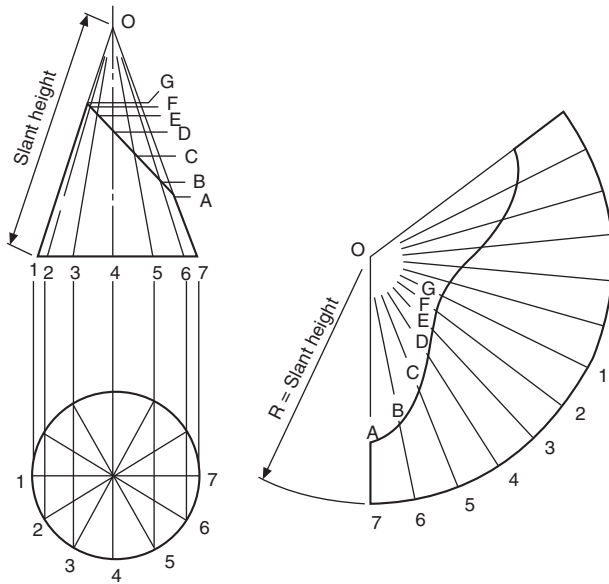
An example of radial-line development is given in Fig. 15.8. The dimensions required to make the development are the circumference of the base and the slant



**Fig. 15.6** Thin Lamina development.



**Fig. 15.7** Interpenetration curve.



**Fig. 15.8** Radial line development.

height of the cone. The chordal distances from the plan view have been used to mark the length of arc required for the pattern; alternatively, for a higher degree of accuracy, the angle can be calculated and then sub-divided. In the front elevation, lines  $O1$  and  $O7$  are true lengths, and distances  $OG$  and  $OA$  have been plotted directly onto the pattern. The lines  $O2$ – $O6$  inclusive are not true lengths, and, where these lines cross the sloping face on the top of the conical frustum, horizontal lines have been projected to the side of the cone and marked  $B, C, D, E,$  and  $F$ . True lengths  $OF, OE, OD, OC,$  and  $OB$  are then marked on the pattern. This procedure is repeated for the other half of the cone. The view on the sloping face will be an ellipse, and the method of projection has been described in Chapter 14.

Part of a square pyramid is illustrated in Fig. 15.9. The pattern is formed by drawing an arc of radius  $OA$  and stepping off around the curve the lengths of the base, joining the points obtained to the apex  $O$ . Distances  $OE$  and  $OG$  are true lengths from the front

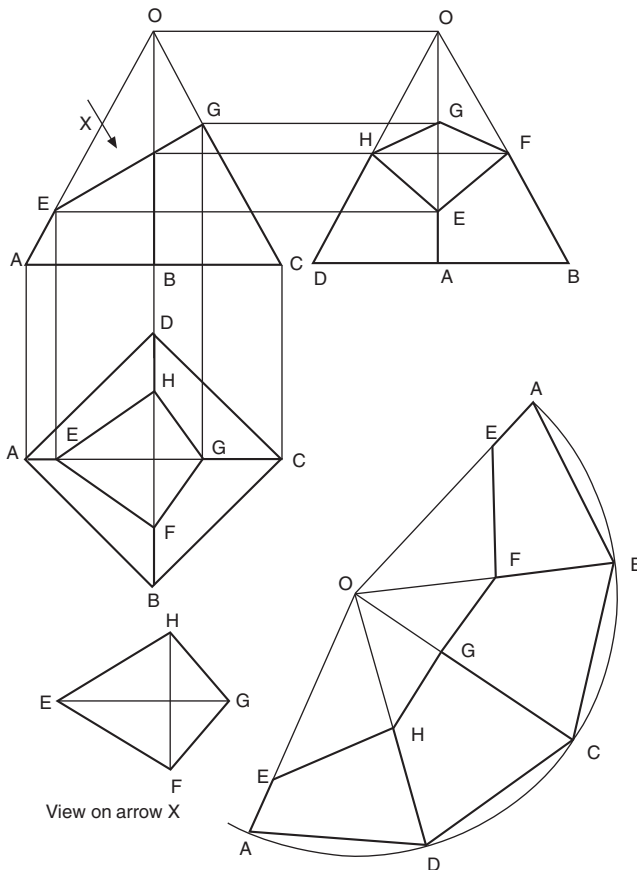
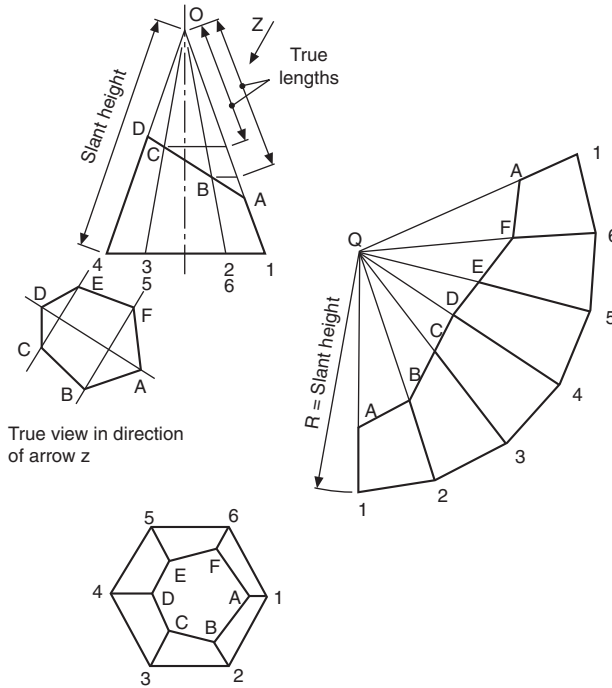


Fig. 15.9 Partial square pyramid development.



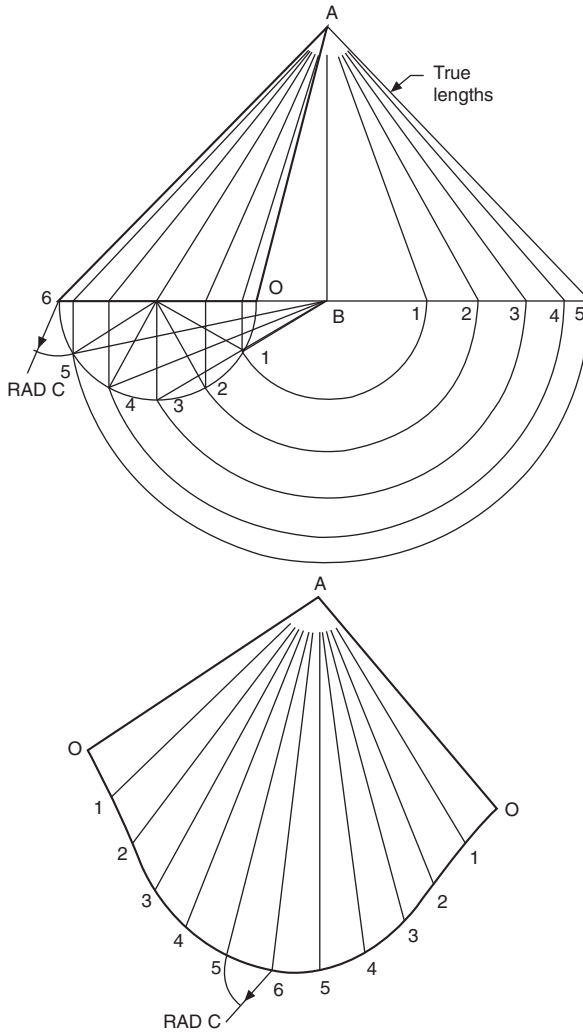
**Fig. 15.10** Partial hexagonal pyramid development.

elevation, and distances OH and OF are true lengths from the end elevation. The true view in direction of arrow X completes the development.

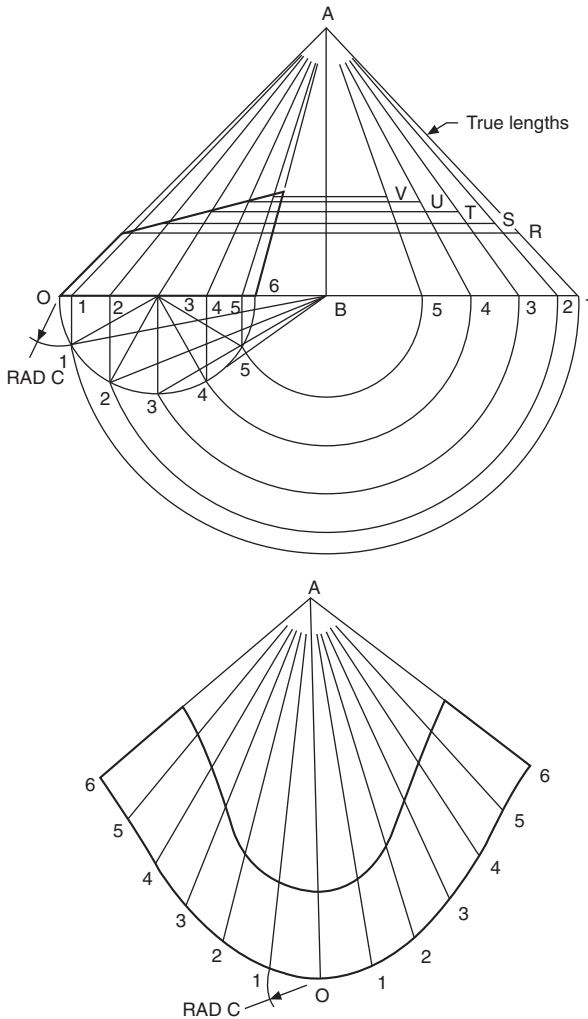
The development of part of a hexagonal pyramid is shown in Fig. 15.10. The method is very similar to that given in the previous example, but note that lines OB, OC, OD, OE, and OF are true lengths obtained by projection from the elevation.

Fig. 15.11 shows an oblique cone which is developed by triangulation, where the surface is assumed to be formed from a series of triangular shapes. The base of the cone is divided into a convenient number of parts (12 in this case) numbered 0–6 and projected to the front elevation with lines drawn up to the apex A. Lines OA and 6A are true-length lines, but the other five shown all slope at an angle to the plane of the paper. The true lengths of lines 1A, 2A, 3A, 4A, and 5A are all equal to the hypotenuse of right-angled triangles where the height is the projection of the cone height and the base is obtained from the part plan view by projecting distances B1, B2, B3, B4, and B5 as indicated.

Assuming that the join will be made along the shortest edge, the pattern is formed as follows. Start by drawing line 6A; then from A draw an arc on either side of the line equal in length to the true length 5A. From point 6 on the pattern, draw an arc equal to the chordal distance between successive points on the plan view.



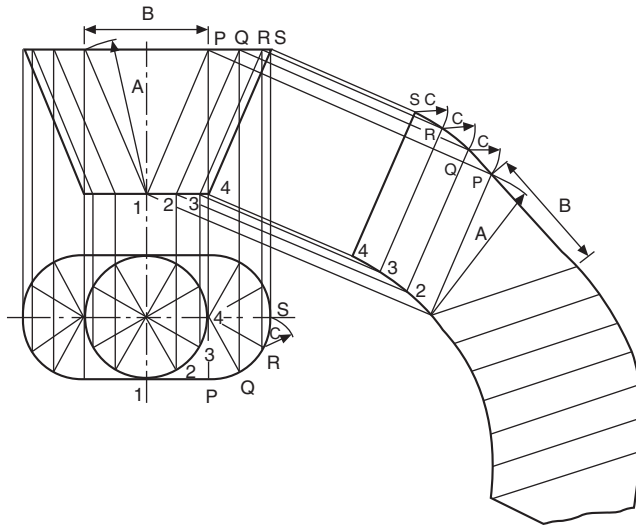
**Fig. 15.11** Oblique cone development.



**Fig. 15.12** Partial oblique cone development.

This curve will intersect the first arc twice at the points marked 5. Repeat by taking the true length of line 4A and swinging another arc from point A to intersect with chordal arcs from points 5. This process is continued as shown on the solution.

Fig. 15.12 shows the development of part of an oblique cone where the procedure described above is followed. The points of intersection of the top of the cone with lines 1A, 2A, 3A, 4A, and 5A are transferred to the appropriate true-length constructions, and true-length distances from the apex A are marked on the pattern drawing.

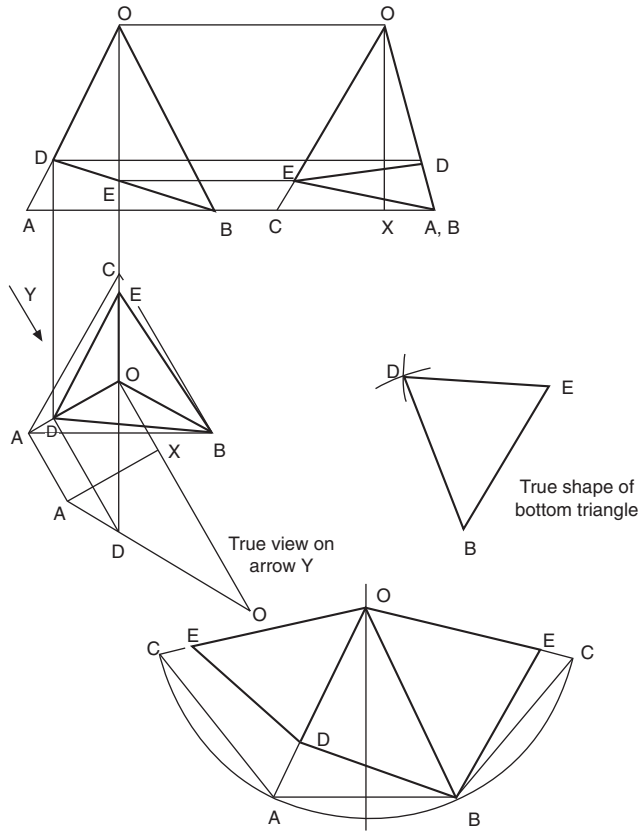


**Fig. 15.13** Cylindrical transition piece development.

A plan and front elevation is given in Fig. 15.13 of a transition piece which is formed from two-halves of oblique cylinders and two connecting triangles. The plan view of the base is divided into 12 equal divisions, the sides at the top into six parts each. Each division at the bottom of the front elevation is linked with a line to the similar division at the top. These lines, P1, Q2, etc., are all the same length. Commence the pattern construction by drawing line S4 parallel to the component. Project lines from points 3 and R, and let these lines intersect with arcs equal to the chordal distances C, from the plan view, taken from points 4 and S. Repeat the process and note the effect that curvature has on the distances between the lines projected from points P, Q, R, and S. After completing the pattern to line P1, the triangle is added by swinging an arc equal to the length B from point P, which intersects with the arc shown, radius A. This construction for part of the pattern is continued as indicated.

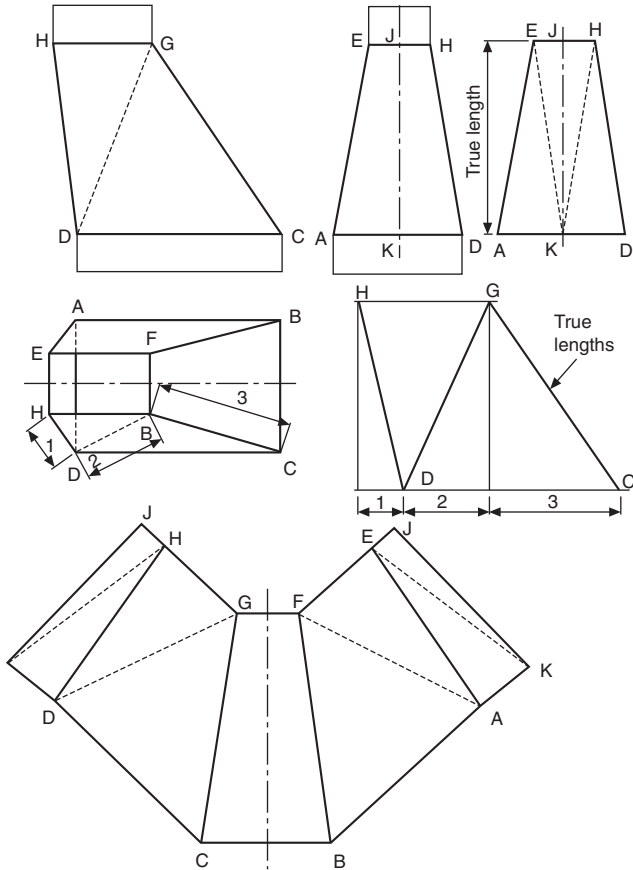
Part of a triangular prism is shown in Fig. 15.14, in orthographic projection. The sides of the prism are constructed from a circular arc of true radius OC in the end elevation. Note that radius OC is the only true length of a sloping side in any of the three views. The base length CA is marked around the circumference of the arc three times, to obtain points A, B, and C.

True length OE can be taken from the end elevation, but a construction is required to find the true length of OD. Draw an auxiliary view in direction with arrow Y, which is square to line OA as shown. The height of the triangle, OX, can be taken from the end elevation. The projection of point D on the side of the triangle gives the true length OD. The true shape at the bottom can be drawn by taking lengths ED, DB, and BE from the pattern and constructing the triangle shown.



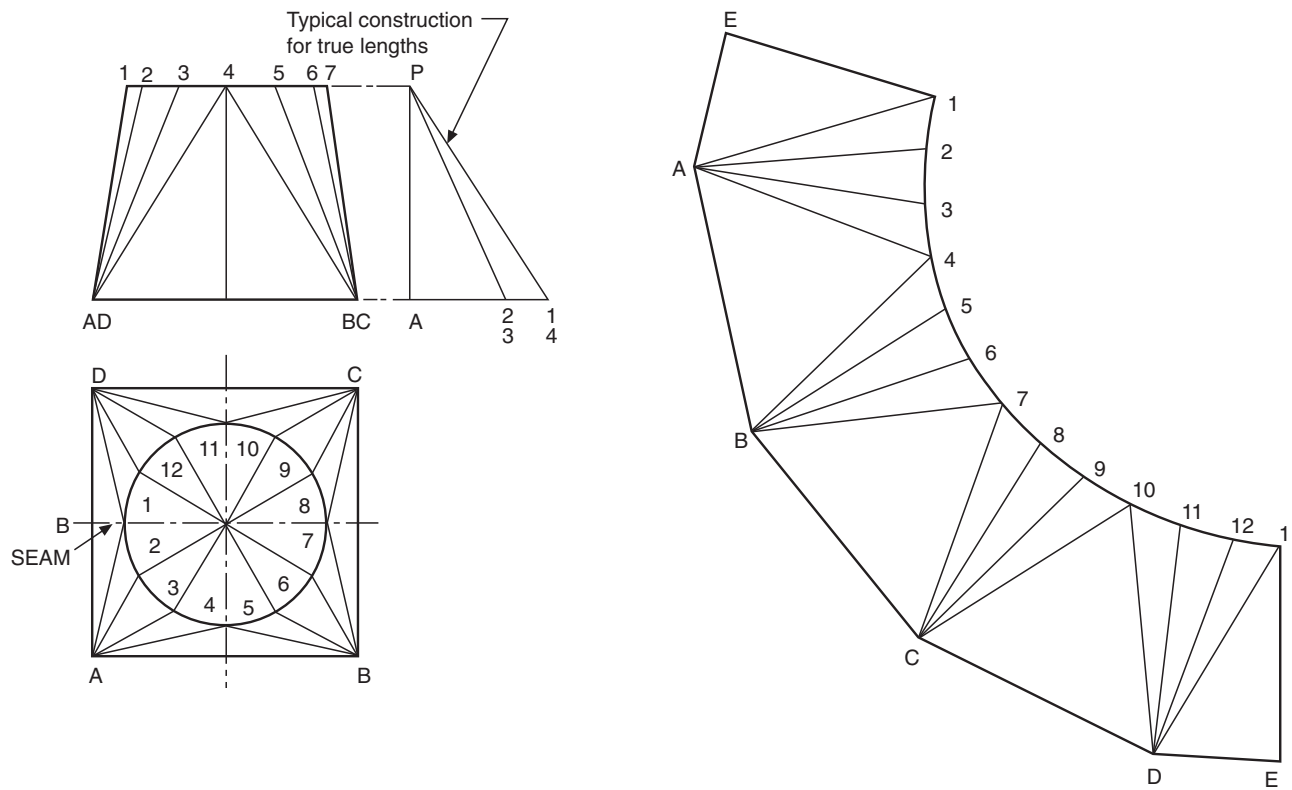
**Fig. 15.14** Partial triangle prism development.

A transition piece connecting two rectangular ducts is given in Fig. 15.15. The development is commenced by drawing the figure CBF<sub>1</sub>G, and the center line of this part can be obtained from the front elevation which appears as line CG, the widths being taken from the plan. The next problem is to obtain the true lengths of lines CG and DH and position them on the pattern; this can be done easily by the construction of two triangles, after the insertion of line DG. The true lengths can be found by drawing right-angled triangles where the base measurements are indicated as dimensions 1, 2, and 3, and the height is equal to the height of the front elevation. The length of the hypotenuse in each case is used as the radius of an arc to form triangles CDG and GDH. The connecting seam is taken along the center line of figure ADHE and is marked JK. The true length of line JK appears as line HD in the front elevation, and the true shape of this end panel has been drawn beside the end elevation to establish the true lengths of the dotted lines EK and HK, since these are used on the pattern to draw triangles fixing the exact position of points K and J.

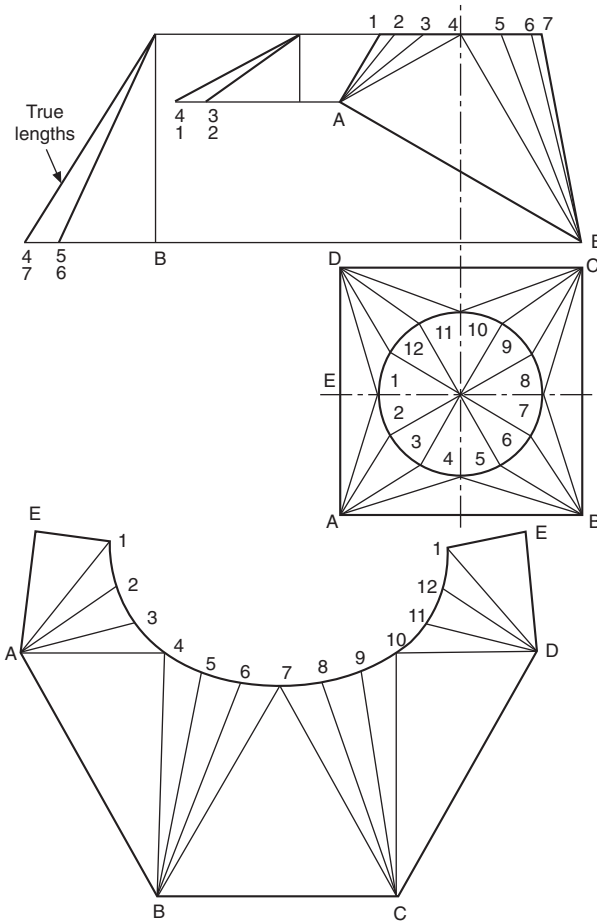


**Fig. 15.15** Rectangular transition piece development.

A transition piece connecting square and circular ducts is shown in Fig. 15.16. The circle is divided into 12 equal divisions, and triangles are formed on the surface of the component as shown. A construction is required to establish the true lengths of lines A1, A2, A3, and A4. These lengths are taken from the hypotenuse of right-angled triangles whose height is equal to the height of the front elevation, and the base measurement is taken from the projected lengths in the plan view. Note that the lengths A2 and A3 are the same, as are A1 and A4, since the circle lies at the center of the square in the plan. The constructions from the other three corners are identical to those from corner A. To form the pattern, draw a line AB, and from A describe an arc of radius A4. Repeat from end B, and join the triangle. From point 4, swing an arc equal to the chordal length between points 4 and 3 in the plan view, and let this arc intersect with the true length A3, used as a radius from point A. Mark the intersection as point 3. This process is repeated to form the pattern shown. The true length of the seam at point E



**Fig. 15.16** Square to circular transition piece development.



**Fig. 15.17** Square to circular transition piece development.

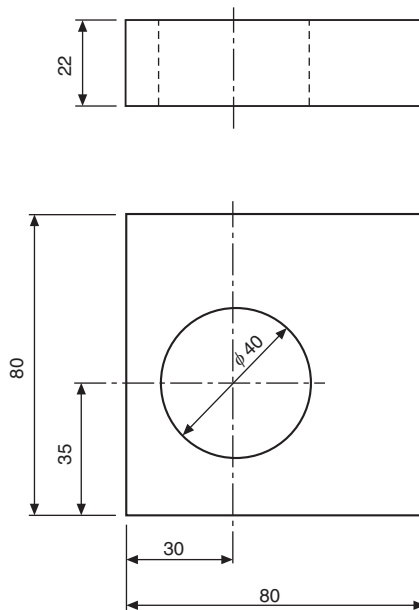
can be measured from the front elevation. Note that, although chordal distances are struck between successive points around the pattern, the points are themselves joined by a curve; hence no ultimate error of any significance occurs when using this method.

Fig. 15.17 shows a similar transition piece where the top and bottom surfaces are not parallel. The construction is generally very much the same as described above, but two separate true-length constructions are required for the corners marked AD and BC. Note that, in the formation of the pattern, the true length of lines AB and CD is taken from the front elevation when triangles AB4 and DC10 are formed. The true length of the seam is also the same as line A1 in the front elevation.

A drawing should provide a complete specification of the component to ensure that the design intent can be met at all stages of manufacture. Dimensions specifying features of size, position, location, geometric control, and surface texture must be defined and appear on the drawing once only. It should not be necessary for the craftsperson either to scale the drawing or to deduce dimensions by the subtraction or addition of other dimensions. Double dimensioning is also not acceptable.

Theoretically any component can be analyzed and divided into a number of standard common geometrical shapes such as cubes, prisms, cylinders, and parts of cones. The circular hole in Fig. 16.1 can be considered as a cylinder through the plate. Dimensioning a component is the means of specifying the design intent in the manufacture and verification of the finished part.

A solid block with a circular hole in it is shown in Fig. 16.1 and to establish the exact shape of the item we require to know the dimensions which govern its length, height, and thickness, and also the diameter and depth of the hole and its position in relation to the surface of the block. The axis of the hole is shown at the intersection of two center lines positioned from the left-hand side and the bottom of the block and these two surfaces have been taken as datums. The length and height have also



**Fig. 16.1** Dimensioning of a hole.

been measured from these surfaces separately – this is a very important point as errors may become cumulative, and this is discussed later in the chapter.

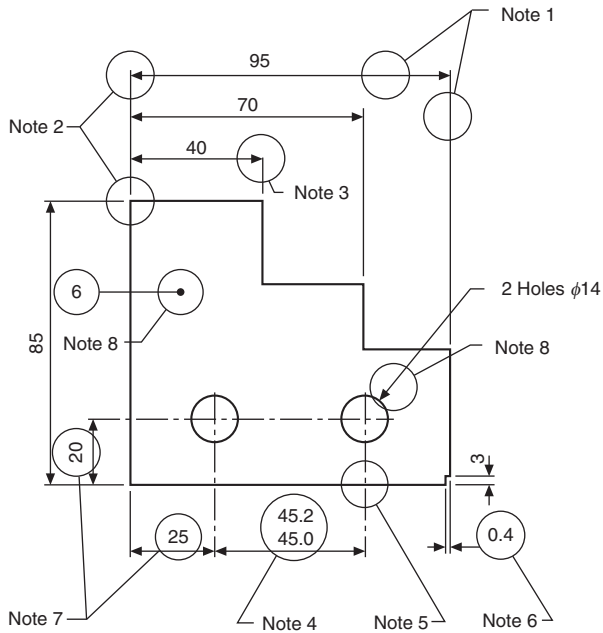
Dimensioning therefore should be undertaken with a view to defining the shape or form and overall size of the component carefully, and also the sizes and positions of the various features, such as holes, counterbores, and tappings from the necessary datum planes or axes.

The completed engineering drawing should also include sufficient information for the manufacture of the part. This involves the addition of notes regarding the materials used, tolerances of size, limits and fits, surface finishes, the number of parts required, and any further comments which result from a consideration of the use to which the completed component will be put. For example, the part could be used in sub-assembly and notes would then make reference to associated drawings or general assemblies.

British Standard 8888 covers all the ISO rules applicable to dimensioning and, if these are adhered to, it is reasonably easy to produce a drawing to a good professional standard.

When construction a drawing the following guide should be followed.

1. Dimension and extension lines are narrow continuous lines 0.35 mm thick, if possible, clearly placed outside the outline of the drawing. As previously mentioned, the drawing outline is depicted with wide lines of 0.7 mm thick. The drawing outline will then be clearly defined and in contrast with the dimensioning system.
2. The extension lines should not touch the outline of the drawing feature and a small gap should be left, about 2–3 mm, depending on the size of the drawing. The extension lines should then continue for the same distance past the dimension line.
3. Arrowheads should be approximately triangular, must be of uniform size and shape, and in every case must touch the dimension line to which they refer. Arrowheads drawn manually should be filled in. Arrowheads drawn by machine need not be filled in.
4. Bearing in mind the size of the actual dimensions and the fact that there may be two numbers together where limits of size are quoted, adequate space must be left between rows of dimensions.
5. Center lines must never be used as dimension lines but must be left clear and distinct. They can be extended, however, with the use of extension lines.
6. Dimensions are quoted in millimetres to the minimum number of significant figures; for example, 19 and not 19.0. In the case of a decimal dimension, always use a nought before the decimal marker, which might not be noticed on a drawing print that has poor line definition. We write 0.4 and not 0.4. It should be stated here that on metric drawings the decimal marker is a comma positioned on the base line between the figures, for example, 5,2 but never 5·2 with a decimal point midway.
7. To enable dimensions to be read clearly, figures are placed so that they can be read from the bottom of the drawing, or by turning the drawing in a clockwise direction, so that they can be read from the right-hand side.
8. Leader lines are used to indicate where specific indications apply. The leader line to the hole is directed toward the center point, terminating at the circumference in an arrow. A leader line for a part number terminates in a dot within the outline of the component. The gauge plate here is assumed to be part number six of a set of inspection gauges.



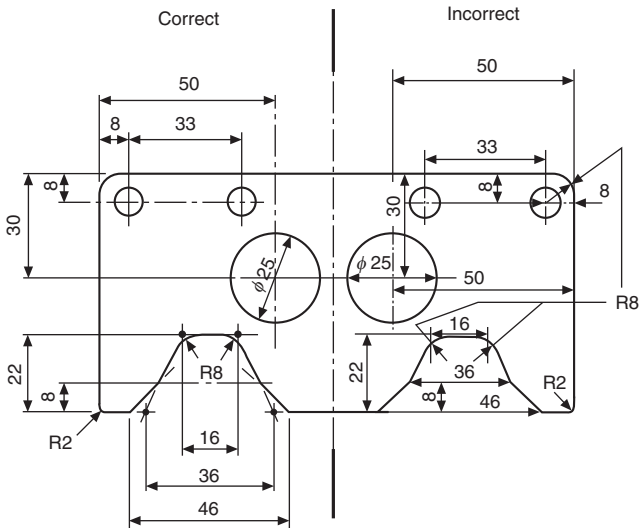
**Fig. 16.2** Elements of a drawing.

**Fig. 16.2** shows a partly completed drawing of a gauge to illustrate the above aspects of dimensioning.

When components are drawn in orthographic projection, a choice often exists regarding where to place the dimensions; the following general rules will give assistance.

1. Start by dimensioning the view which gives the clearest understanding of the profile or shape of the component.
2. If space permits, and obviously this varies with the size and degree of complexity of the subject, place the dimensions outside the profile of the component as first choice.
3. Where several dimensions are placed on the same side of the drawing, position the shortest dimension nearest to the component and this will avoid dimension lines crossing.
4. Try to ensure that similar spacings are made between dimension lines as this gives a neat appearance on the completed drawing.
5. Overall dimensions which are given for surfaces that can be seen in two projected views are generally best positioned between these two views.

Remember that drawings are the media to communicate the design intent used for the manufacturing and verification units. Therefore always check over your drawing, view it, and question yourself. Is the information complete? Ask yourself whether or not the machinist or fitter can use or work to the dimension you have quoted to make the item. Also, can the inspector verify the figure – in other words, is it a measurable distance?



**Fig. 16.3** Good and bad dimensioning practices.

**Fig. 16.3** shows a component which has been partly dimensioned to illustrate some of the principles involved.

Careless and untidy dimensioning can spoil an otherwise sound drawing and it should be stated that many marks are lost in examinations due to poor quality work.

## Property indicators

Property indicator symbols preceding dimension values are used to indicate the shape of the feature being dimensioned (see **Fig 16.4**).

Property indicators are not required for the presentation of linear dimensions between two parallel planes or two parallel straight lines or angular dimensions between two intersecting planes or two intersecting straight lines.

## *Dimensioning of features not drawn to scale*

This method of indication is by underlining a particular dimension with a wide line as indicated in **Fig. 16.5**. This practice is very useful where the dimensional change does not impair the understanding of the drawing.

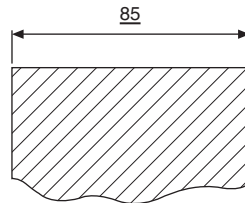
## *Chain dimensioning and auxiliary dimensioning*

Chains of dimensions should only be used where the possible accumulation of tolerances does not endanger the function of the part.

A plan view of a twist drill stand is given in **Fig. 16.6** to illustrate chain dimensioning. Now each of the dimensions in the chain would be subject to a

Property Indicator Symbol	Description	Associated property	Example
∅	Diameter	Cylindrical or circular feature specified by its diameter.	Figure 16.11
R	Radius	Cylindrical or circular feature specified by its diameter.	Figure 16.12
□	Square	Square feature with four equal angles and four equal sides specified by a side dimension.	Figure 16.25
S ∅	Spherical Diameter	Spherical feature specified by its diameter.	Figure 16.13
SR	Spherical Radius	Spherical feature specified by its radius.	Figure 16.13
⌒	Arc length	Curved feature specified by its Curvilinear dimension (e.g. length along surface).	Figure 16.15
≡	Thickness (of thin objects)	Two offset surfaces specified by the distance between them.	Figure 16.36
∇	Depth	Depth of a hole or internal feature.	Figure 16.31
⊓	Cylindrical counterbore	Cylindrical hole with a flat bottom specified by its diameter and depth.	Figure 16.31
∨	Countersink	Circular chamfer specified by a diameter and angle.	Figure 16.33
α→	Developed length	Length of feature prior to bending or forming.	Figure 16.38
↔	Between	Indication of the extent of a restricted area, used in conjunction with reference letters.	Figure 16.39 Figure 28.9

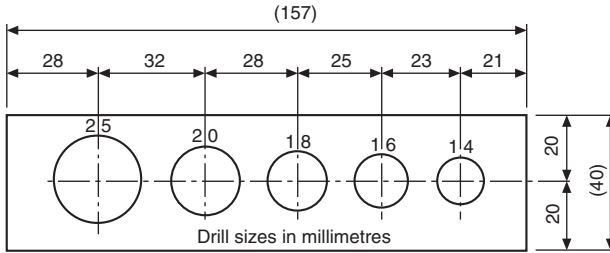
**Fig. 16.4** Property Indicators.



**Fig. 16.5** Dimension which is not to scale.

manufacturing tolerance since it is not possible to mark out and drill each of the center distances exactly. As a test of drawing accuracy, start at the left-hand side and mark out the dimensions shown in turn. Measure the overall figure on your drawing and check with the auxiliary dimension given. Note the considerable variation in length, which results from small errors in each of the six separate dimensions in the chain, which clearly accumulate. Imagine the effect of marking out say 20 holes for rivets in each of two plates; how many holes would eventually line up? The overall length is shown in parentheses (157) and is known as an *auxiliary dimension*. This dimension is not the one which is worked to in practice but is given purely for reference purposes. You will

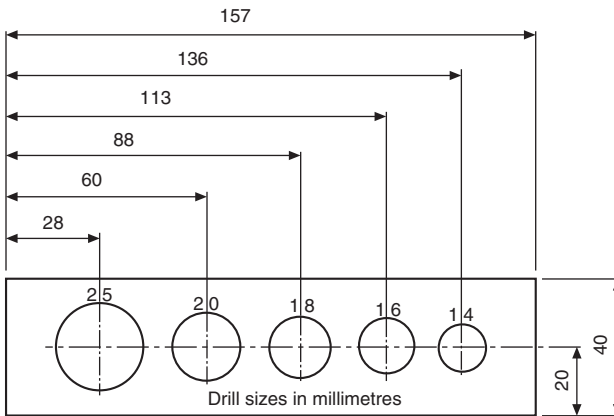
now appreciate that it will depend on the accuracy with which each of the pitches in the chain is marked out.



**Fig. 16.6** Chain dimensioning.

**Parallel dimensioning**

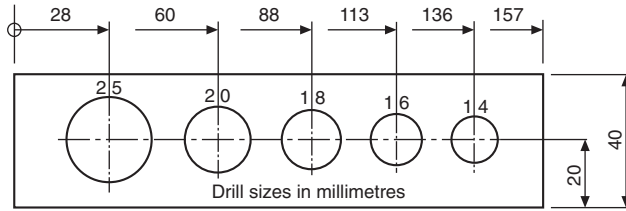
Improved positional accuracy is obtainable by dimensioning more than one feature from a common datum, and this method is shown in Fig. 16.7. The selected datum is the left-hand side of the stand. Note that the overall length is not an auxiliary dimension, but a dimensional length in its own right.



**Fig. 16.7** Dimensioning from a common datum.

**Running dimensioning**

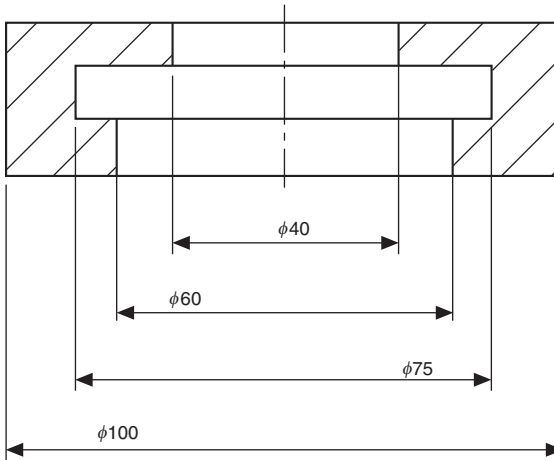
Is a simplified method of parallel dimensioning conferring the advantage that the indication requires less space. The common origin is indicated as shown (Fig. 16.8) with a narrow continuous circle; the dimensions are placed near the respective arrowheads.



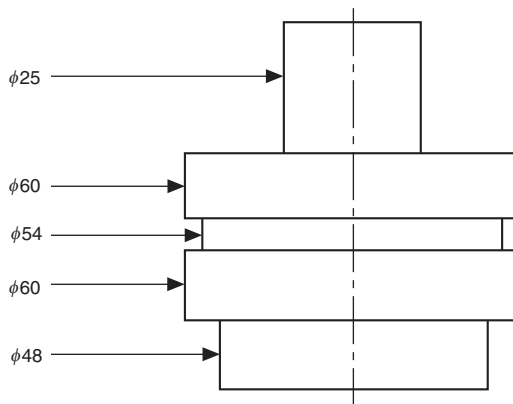
**Fig. 16.8** Running dimensioning.

### ***Staggered and simplified dimensions***

For greater clarity, a number of parallel dimensions may be indicated as shown in [Figs. 16.9 and 16.10](#).



**Fig. 16.9** Staggered dimensioning.



**Fig. 16.10** Simplified dimensioning.

### Dimensioning circles

The symbol  $\varnothing$  preceding the figure is used for specifying diameters and it should be written as large as the figures which establish the size, e.g.  $\varnothing 65$ . Alternative methods of dimensioning diameters are given in Fig. 16.11. The size of hole and space available on the drawing generally dictates which method the designer chooses.

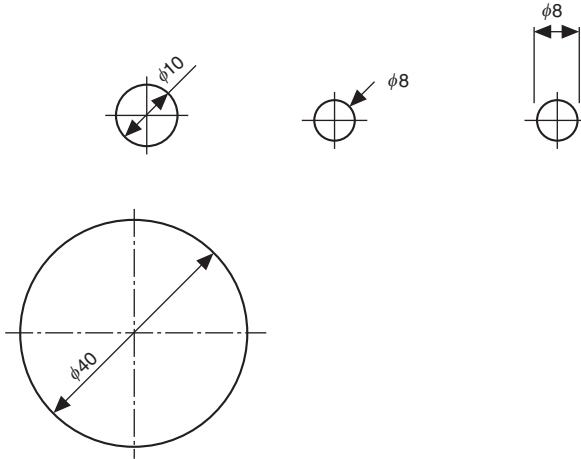


Fig. 16.11 Examples of dimensioning circles.

### Dimensioning radii

Alternative methods are shown in Fig. 16.12 where the position of the center of the arc need not be located. Note that the dimension line is drawn through the arc center or lies in a line with it in the case of short distances and the arrowhead touches the arc.

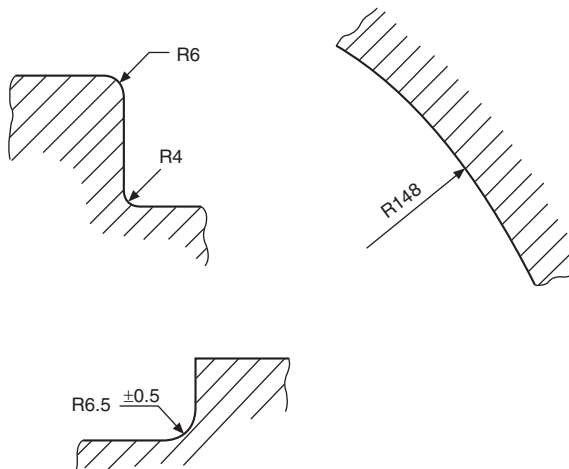
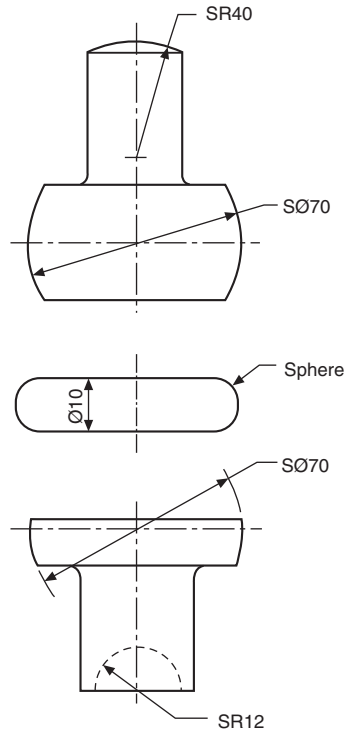


Fig. 16.12 Examples of dimensioning radii.

### ***Dimensioning spherical radii and diameters***

Spherical radii and diameters are dimensioned as shown in [Fig. 16.13](#). The letter S precedes the  $\varnothing$  symbol (diameter) or letter R (radius).



**Fig. 16.13** Examples of dimensioning spherical diameters and radii.

### ***Dimensioning curves***

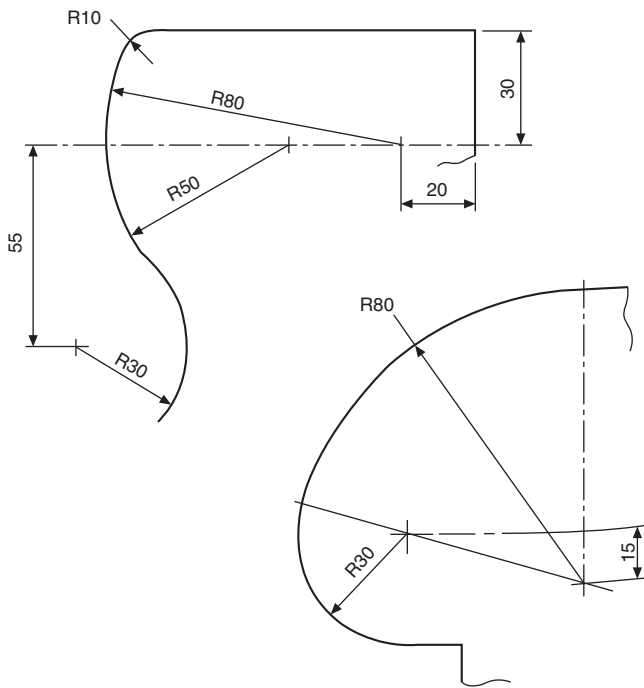
A curve formed by the blending of several radii must have the radii with their centers of curvature clearly marked as indicated in [Fig. 16.14](#).

## **Dimensioning curves using arc length, chord length or angular distance**

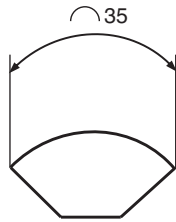
The dimensioning of a portion of a curve can be by specifying Arc length or chord length or Angular distance see [Fig. 16.15](#).

### ***Dimensioning Irregular Curves***

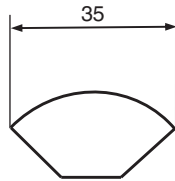
Irregular curves may be dimensioned by the use of ordinates. To illustrate the use of ordinates, a section through the hull of a boat is shown ([Fig. 16.16](#)). Since the hull is



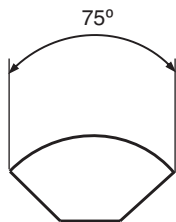
**Fig. 16.14** Examples of dimensioning curves.



Arc length



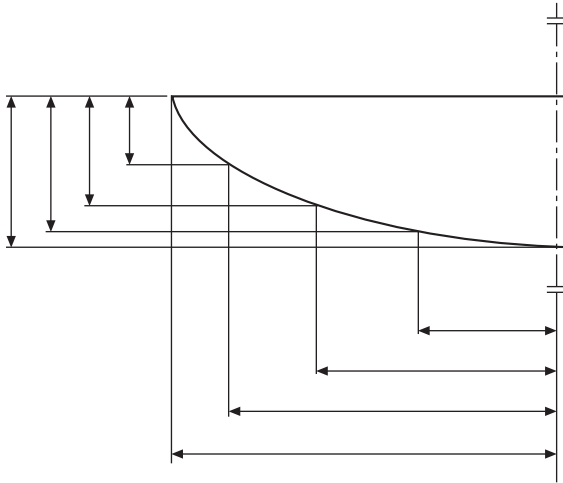
Chord length



Angular Length

**Fig. 16.15** Arc, Chord and Angular length dimensions.

symmetrical about the vertical center line, it is not necessary to draw both halves in full and if the curve is presented in this manner then two short thick parallel lines are drawn at each end of the profile at right angles to the center line. The outline is also extended slightly beyond the center line to indicate that the shape is to be continued. Ordinates are then positioned on the drawing and the outline passes through each of the chosen fixed points (Fig. 16.16).



**Fig. 16.16** Dimensioning with ordinates.

### ***Unidirectional and aligned dimensions***

Both methods are in common use.

1. Unidirectional dimensions are drawn parallel with the bottom of the drawing sheet; also, any notes which refer to the drawing use this method (Fig. 16.17).
2. Aligned dimensions are shown in parallel with the related dimension line and positioned so that they can be read from the bottom of the drawing or from the right-hand side (Fig. 16.18).

### ***Angular dimensions***

Angular dimensions on engineering drawings are expressed as follows:

- (a) Degrees, e.g.  $30^\circ$ .
- (b) Degrees and minutes, e.g.  $30^\circ 40'$ .
- (c) Degrees, minutes, and seconds, e.g.  $30^\circ 40' 20''$ .

For clarity a full space is left between the degree symbol and the minute figure and also between the minute symbol and the second figure.

In the case of an angle of less than  $1^\circ$  it should be preceded by  $0^\circ$ , e.g.  $0^\circ 25'$ .

Fig. 16.19 shows various methods of dimensioning angles.

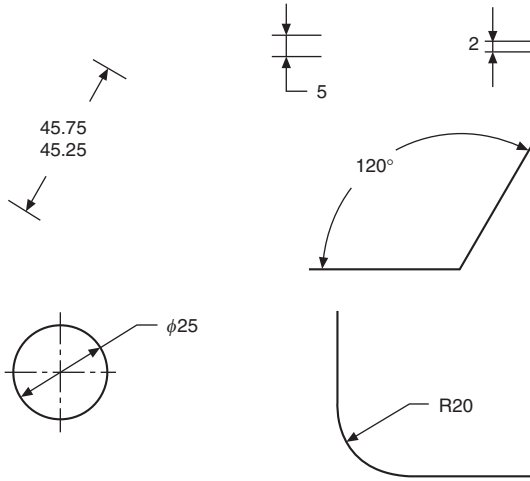


Fig. 16.17 Unidirectional dimensions.

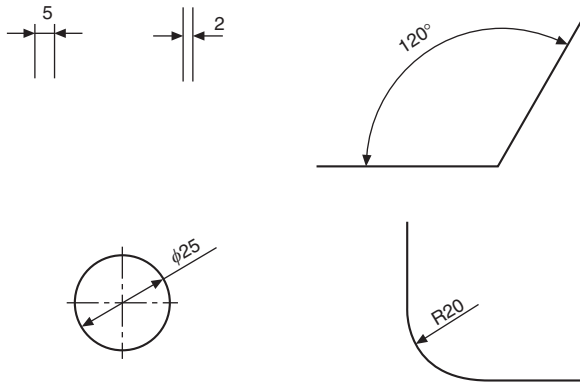


Fig. 16.18 Aligned Dimensions.

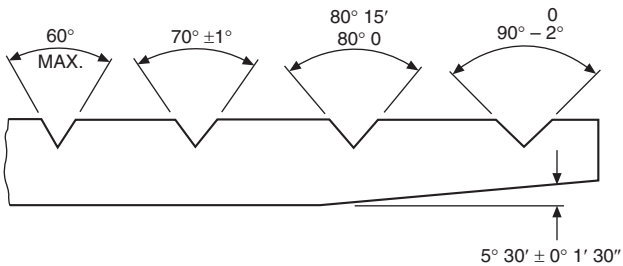
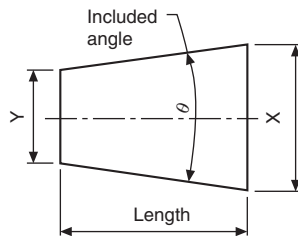


Fig. 16.19 Examples of angular dimensioning.

## Tapers

In Figs. 16.20 the difference in magnitude between dimensions  $X$  and  $Y$  (whether diameters or widths) divided by the length between them defines a ratio known as a *taper*.

$$\text{Taper} = \frac{X - Y}{\text{length}} = 2 \tan \frac{\theta}{2}$$



**Fig. 16.20** Elements of a taper.

For example, the conical taper in Fig. 16.21

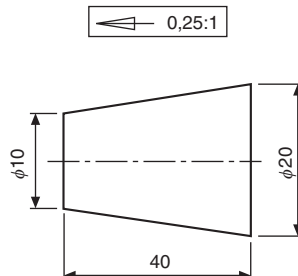
$$= \frac{20 - 10}{40} = \frac{10}{40} = 0.25$$

and may be expressed as rate of taper 0.25:1 on diameter.

The ISO recommended symbol for taper is  $\leftarrow$ , and this symbol can be shown on drawings accompanying the rate of taper, i.e.  $\leftarrow$  0.25:1. see Fig. 16.21.

The arrow indicates the direction of taper.

When a taper is required as a Theoretical exact dimension (TED) it is enclosed in a rectangular box, see Fig. 16.21. Normally there should be a geometrical tolerance associated with the TED such as Profile of a Surface.



**Fig. 16.21** Taper indicated as a TED.

## Dimensioning tapers

The size, form, and position of a tapered feature can be defined by calling for a suitable combination of the following:

1. the rate of taper, or the included angle;
2. the diameter or width at the larger end;
3. the diameter or width at the smaller end;
4. the length of the tapered feature;
5. the diameter or width at a particular cross-section, which may lie within or outside the feature concerned;
6. the locating dimension from the datum to the cross-section referred to above.

Care must be taken to ensure that no more dimensions are quoted on the drawing than are necessary. If reference dimensions are given to improve communications, then they must be shown in brackets, e.g. (1:5 taper).

Fig. 16.22 gives four examples of the methods used to specify the size, form, and position of tapered features.

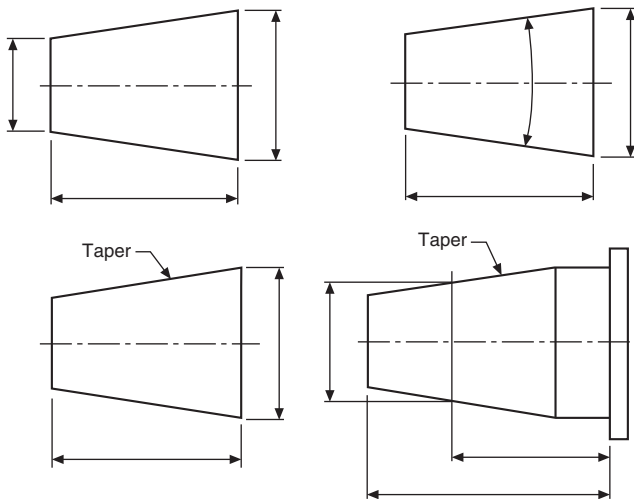


Fig. 16.22 Examples of dimensioning tapered features.

## Dimensioning two mating tapers

When the fit to a mating part or gauge is necessary, a tried and successful method used in manufacturing units is to add the following information to the feature(s).

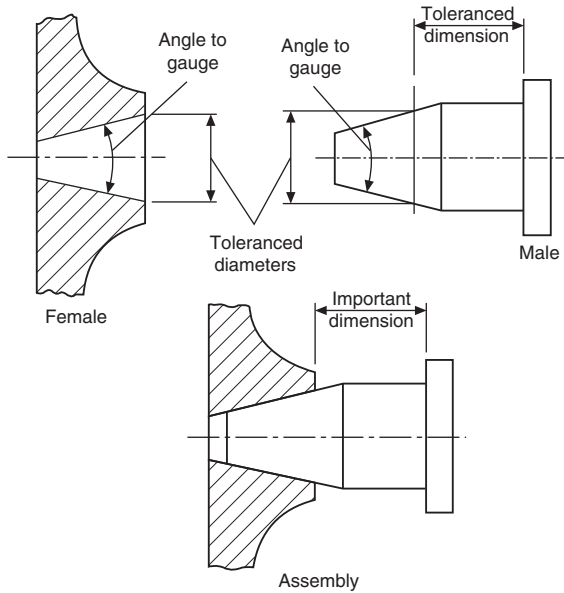
1. 'To FIT PART NO. YYY'.
2. 'TO FIT GAUGE (PART NO. GG)'.

When note 2 is added to the drawing, this implies that a 'standard rubbing gauge' will give an acceptable even marking when 'blued'. The functional requirement

whether the end-wise location is important or not, will determine the method and choice of dimensioning.

An example of dimensioning two mating tapers when end-wise location is important is shown in Fig. 16.23.

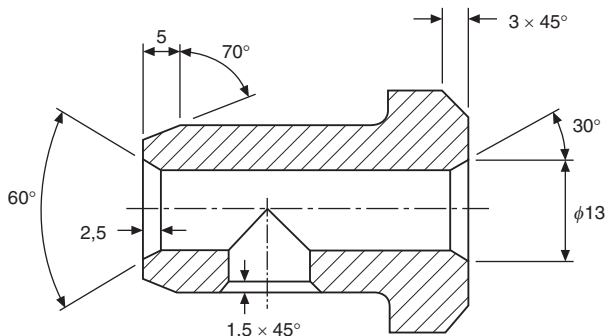
For more accurate repeatability of location, the use of Geometric Tolerancing and a specific datum is recommended. Additional information on this subject may be found in BS ISO 3040.



**Fig. 16.23** Dimensioning mating tapers.

### ***Dimensioning chamfers***

Alternative methods of dimensioning internal and external chamfers are shown in Fig. 16.24.



**Fig. 16.24** Examples of dimensioning chamfers.

### Dimensioning squares or flats

Fig. 16.25 shows a square machined on the end of a shaft so that it can be turned by means of a spanner.

The narrow diagonal lines are added to indicate the flat surface.

Part of a spindle which carries the chain wheel of a cycle, secured by a cotter pin, illustrates a flat surface which is not at the end of the shaft (Fig. 16.26).

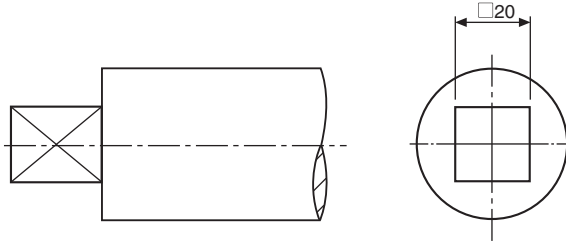


Fig. 16.25 Dimensioning a square.

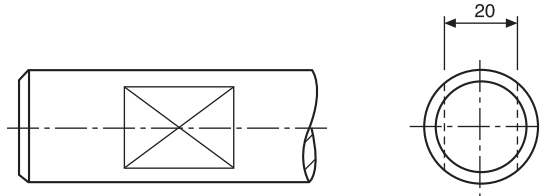


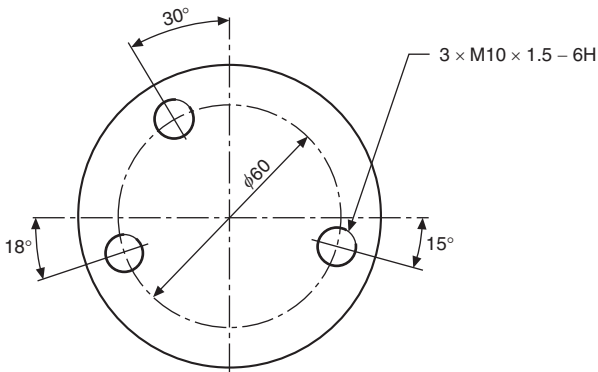
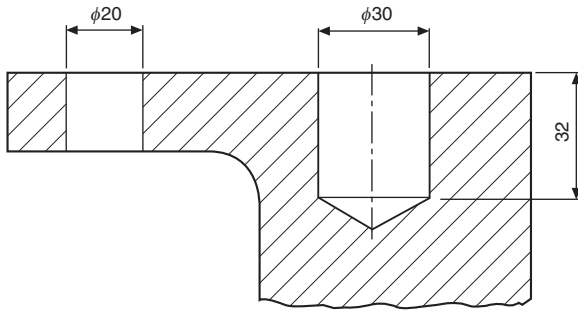
Fig. 16.26 Dimensioning a flat.

### Dimensioning holes

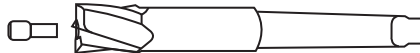
The depth of drilled holes, when stated in note form, refers to the depth of the cylindrical portion and not to the point left by the drill. If no other indication is given they are assumed to go through the material. Holes in flanges or bosses are generally positioned around a pitch circle and may be spaced on the main center lines of the component, or as shown in Fig. 16.27. It is a default condition that hole patterns on a pitch circle diameter are equally spaced unless dimensioned otherwise. There is no requirement (as was past practise) to indicate this condition using the word 'EQUISPACED' in the hole call out. The angles of the spacings may be omitted when the intent is evident as shown in chapter 22, Figs. 22.34 and 22.35.

### Dimensioning counterbores

A drilling machine is used for this operation, and a typical counterboring tool is shown in Fig. 16.28. The operation involves enlarging existing holes, and the depth of the



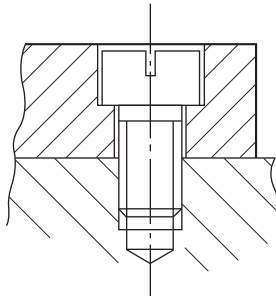
**Fig. 16.27** Dimensioning through, depth and pitch circle holes.



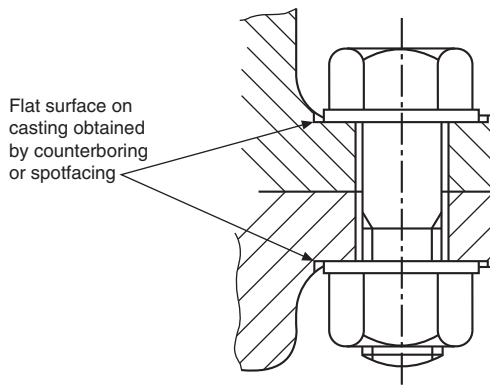
**Fig. 16.28** Counterbore tool.

enlarged hole is controlled by a stop on the drilling machine. The location of the counterbored hole is assisted by a pilot at the tip of the tool which is a clearance fit in the previously drilled hole. A typical use for a counterbored hole is to provide a recess for the head of a screw, as shown in Fig. 16.29 or a flat surface for an exposed nut or bolt, as in Fig. 16.30. The flat surface in Fig. 16.30 could also be obtained by spotfacing.

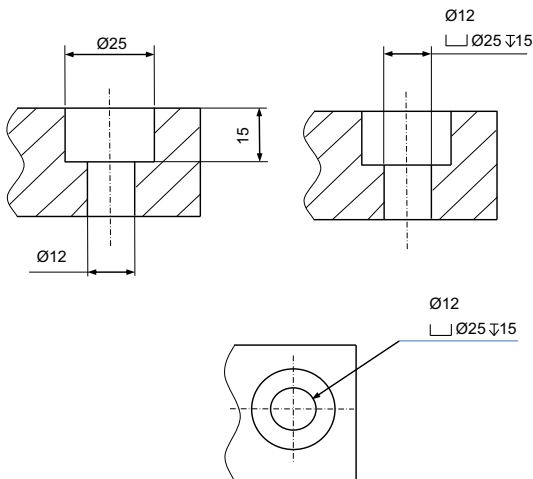
Fig. 16.31 shows methods of dimensioning counterbores. Note that, in every case, it is necessary to specify the size of counterbore required. It is not sufficient to state 'COUNTERBORE FOR M10 RD HD SCREW', since obviously the head of the screw will fit into any counterbore which is larger than the head.



**Fig. 16.29** Example of clearance hole for a screw head.



**Fig. 16.30** Example of flat surfaces for screw head seating.

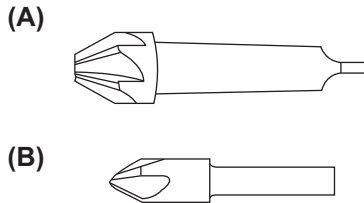


**Fig. 16.31** Examples of dimensioning counterbores.

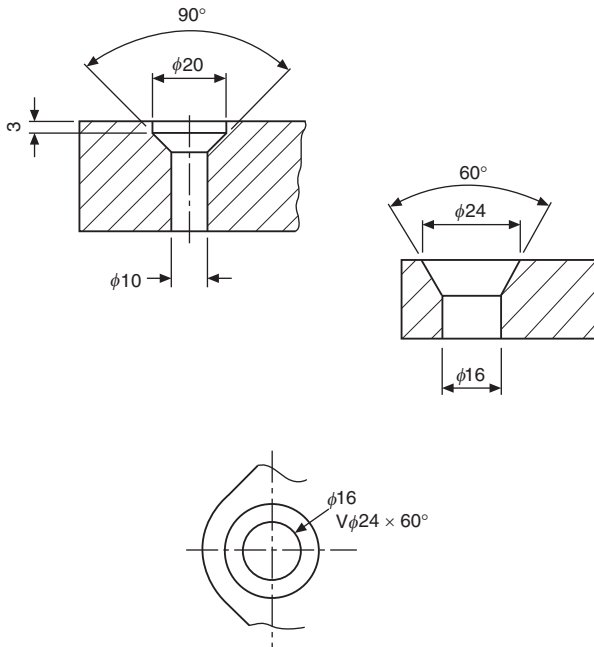
## Dimensioning countersunk holes

Countersinking is also carried out on a drilling machine, and Fig. 16.32 shows typical tools. Included angles of  $60^\circ$  and  $90^\circ$  are commonly machined, to accommodate the heads of screws and rivets to provide a flush finish (Fig. 16.33).

*Note:* Refer to manufacturers' catalogs for dimensions of suitable rivets and screws.



**Fig. 16.32** (A) Taper-shank countersink tool (with  $60^\circ$  or  $90^\circ$  included angle of countersink). (B) Straight-shank machine countersink tool (with  $60^\circ$  or  $90^\circ$  included angle of countersink).

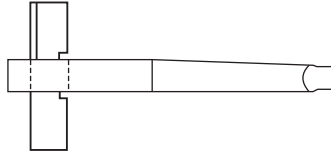


**Fig. 16.33** Examples of dimensioning countersunk holes.

## Dimensioning spotfaces

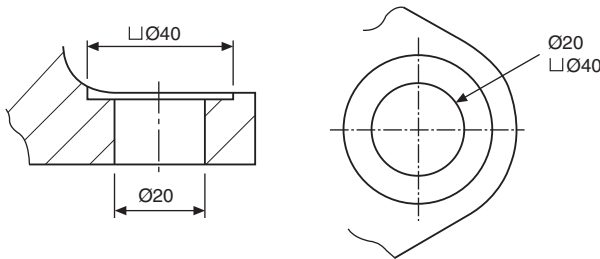
Spotfacing is a similar operation to counterboring, but in this case the metal removed by the tool is much less. The process is regularly used on the surface of castings, to provide a flat seating for fixing bolts. A spotfacing tool is shown in Fig. 16.34,

where a loose cutter is used. The length of cutter controls the diameter of the spotface. As in the counterboring operation, the hole must be previously drilled, and the pilot at the tip of the spotfacing tool assists in location.



**Fig. 16.34** Spotface tool.

**Fig. 16.35** shows the method of dimensioning. Note that, in both cases, the depth of spotface is not specified (as in a counterbore) as it is just sufficient to remove the rough surface of the casting over the 40 mm diameter area.

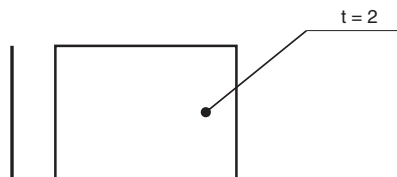


**Fig. 16.35** Dimensioning a spotface.

## Dimensioning of thin parts

On thin parts where it may be difficult to specify the thickness by conventional dimension lines and arrows, the thickness can be specified by the symbol “t =” (see **Fig. 16.4**) followed by the thickness dimension attached to one surface with a leader line terminated with a point. See **Fig. 16.36**.

When thin parts are represented on a drawing as a wide line it is important to identify which surface a dimension applies to. Surface indicator symbols can be added to the wide line to indicate which surface is being dimensioned. The short line segment of

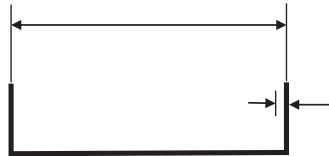


**Fig. 16.36** Dimensioning of a thin part in plan view.

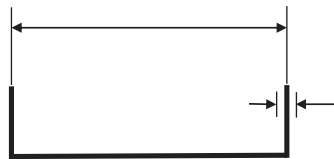
the symbol represents the non-dimensioned surface. Where two short line segments are indicated the dimension applies to the median plane. See Fig. 16.37.



Dimension applies to inside surface



Dimension applies to outside surface



Dimension applies to median plane

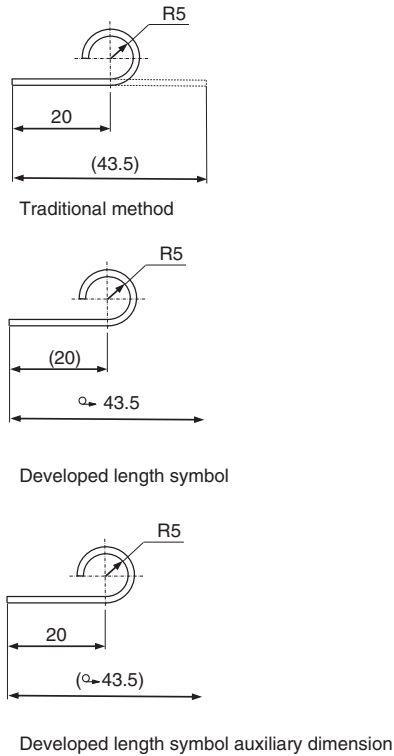
**Fig. 16.37** Indicating dimensioned surface.

## Dimensioning of developed parts

Traditionally on parts which are folded or rolled the initial outline of a finished workpiece (e.g. the length of a workpiece before bending) is represented by long dashed double-dotted narrow lines and dimensioned as an auxiliary dimension. Where the initial outline is not represented, a symbol for developed length (see Fig. 16.4) can be used to indicate the overall length. The developed length symbol and dimension may also be shown as an auxiliary dimension if appropriate. See Fig. 16.38.

## Dimensioning restricted areas

Where a requirement applies to a restricted portion of a feature it is important to clearly identify the extents of the requirement. A long dashed dotted wide line indicating



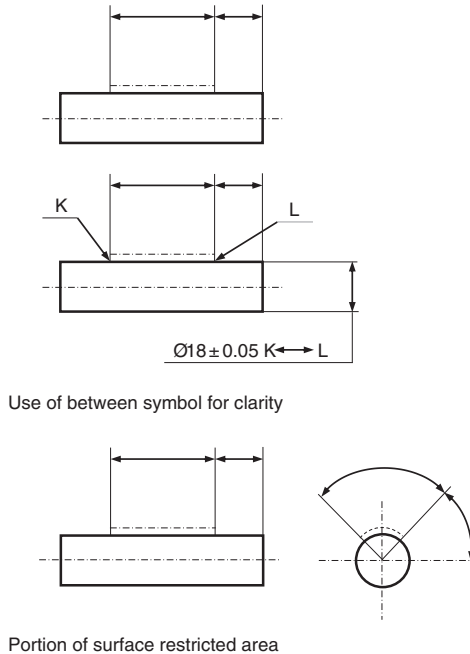
**Fig. 16.38** Examples of dimensioning developed parts.

the restricted area should be drawn adjacent and parallel to the surface. When the requirement applies to the entire width or circumference of the surface, only the length of the area needs to be indicated. When the requirement applies to a portion of a cylindrical feature, the angular extent should be dimensioned in a separate view. If greater clarification is required as to the start and finish of the restricted area the between symbol can be used. See Fig. 16.39.

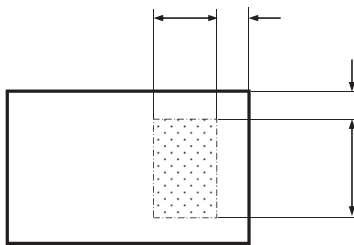
When dimensioning of restricted areas on other than surfaces of revolution, the extents of the area shall be dimensioned to fully define the area. It is recommended that the area should be emphasized by shading or hatching. See Fig. 16.40.

## Use of the between symbol

The property indicator between symbol (see Fig. 16.4) and associated annotation may be used when the limits of a feature characteristic may be ambiguous, i.e. the extent of a specific tolerance. The extent i.e. the start and finish of the restricted area, are identified by letters, leader lines and reference lines if required. The Authors recommend



**Fig. 16.39** Examples of dimensioning restricted area.



**Fig. 16.40** Dimensioning restricted area in plan view.

using the letters in the middle of the alphabet so as not to clash with Datum letters (A onwards) and Sections (Z backwards) See Figs. 16.39 and 28.9.

## Dimensioning of edges

Traditionally, the shape and condition of the majority of edges have been defined in a note such as “Remove all burrs and sharp edges” sometimes including a size e.g. “with a 0.5 mm max rad or chamfer”. Where a specific condition of an edge was required it was often controlled by a note such as “leave edge sharp” or fully dimensioned in a separate view. ISO 13715 introduces a symbolic specification system to define the

size and condition of edges. When a size is indicated, the position of it within the symbol dictates the condition/profile of the edge. See Fig. 16.41. These symbols can be applied to specific edges or applied generally to all or some of the part if referenced in a note.

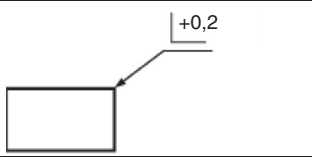
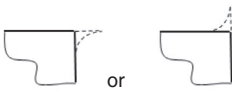
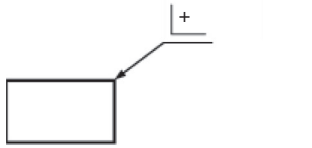
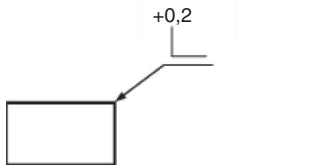
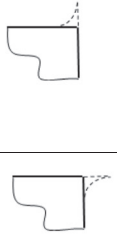
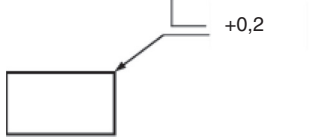
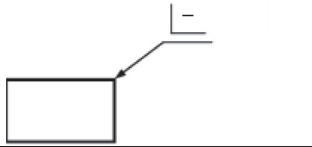

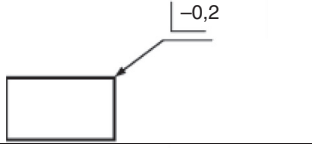
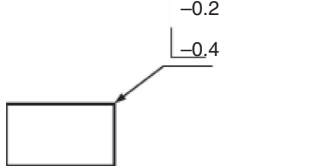
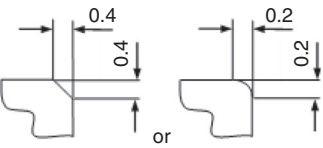
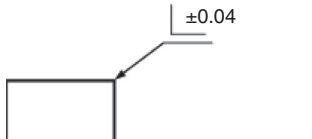

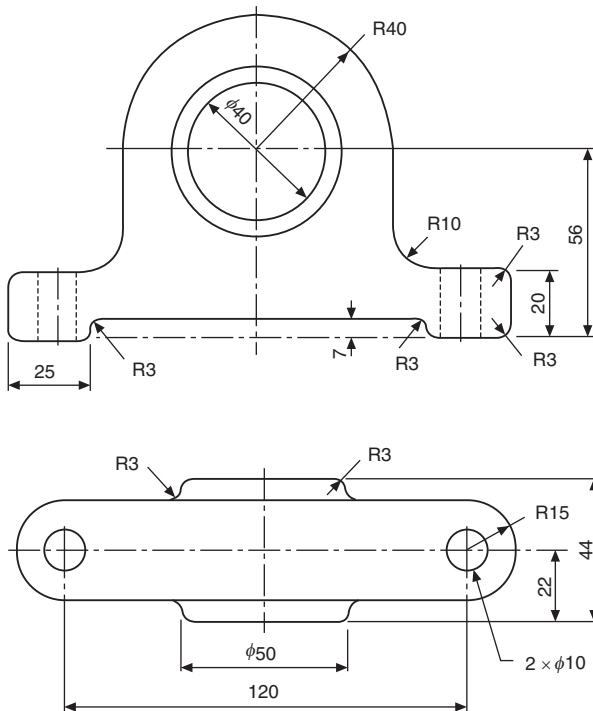
Symbol/indication	Edge condition/profile	Description
		External edge with a burr of undefined direction permitted up to 0,2mm
		External edge with a burr of undefined direction and size permitted
		External edge with a burr permitted up to 0,2mm in a defined direction.
		
		External edge with no burr. Chamfer or radius of undefined size permitted.
		External edge with no burr. Chamfer or radius permitted up to 0.2mm.
		External edge with no burr. Chamfer or radius permitted between 0.4mm and 0.2mm.
		External edge with a burr of undefined direction or an undercut up to 0.04mm permitted. (sharp edge).

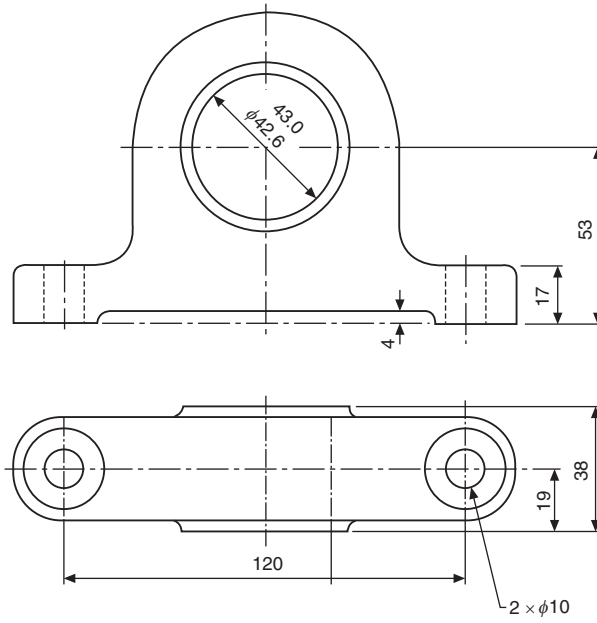
Fig. 16.41 Examples of dimensioning edges.

## Dimensioning for manufacture

It should be emphasized that dimensioning must be performed with the user of the drawing very much in mind. In the case of the finished bearing housing shown in Fig. 16.42 two different production processes are involved in its manufacture, namely: casting and machining of the component. It is sometimes preferable to produce two separate drawings, one to show the dimensions of the finished casting and the other to show the dimensions which are applicable to the actual machining operation. Fig. 16.42 shows a suitable drawing for the casting patternmaker. Allowances are made for machining and also for the fact that the casting will shrink when it cools. The machinist will take the rough casting and remove metal to produce the finished component, all other surfaces having a rough finish. Fig. 16.43 shows the required dimensions for machining. Note that the bore of the casting is required to be finished between the two sizes quoted for functional purposes.



**Fig. 16.42** Example of dimensioning for rough machining.



**Fig. 16.43** Example of dimensioning for finished machining.

# Screw threads and conventional representations

## Screw threads

The most common application of the helix is in a screw thread which follows the path of the helix. Screw threads may be either left or right hand and these are shown pictorially in Fig. 17.1. Notice the slope of the thread and the position of the index finger on each hand. The left-hand thread is used for special applications and the right-hand thread is the one normally used on nuts and bolts. The thread illustrated has a vee-section.

The following terms are associated with screw threads:

- The *thread pitch* is the distance between corresponding points on adjacent threads. Measurements must be taken parallel to the thread axis.
- The *major diameter* or *outside diameter* is the diameter over the crests of the thread, measured at right angles to the thread axis.
- The *crest* is the most prominent part of the thread, internal or external.
- The *root* lies at the bottom of the groove between two adjacent threads.
- The *flank* of the thread is the straight side of the thread between the crest and root.
- The *minor diameter*, *root diameter*, or *core diameter* is the smallest diameter of the thread measured at right angles to the thread axis.
- The *effective diameter* is measured at right angles to the thread axis and is the diameter on which the width of the spaces is equal to the width of the threads.
- The *lead* of a thread is the axial movement of the screw in one revolution.

The terms are illustrated in Fig. 17.2.

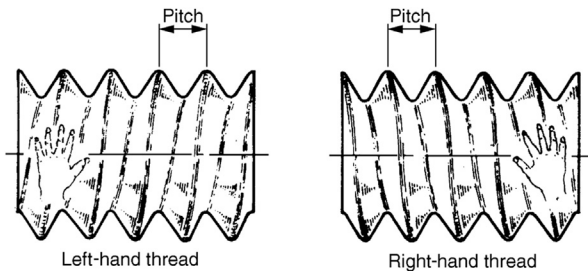


Fig. 17.1 Pictorial view of left and right handed threads.

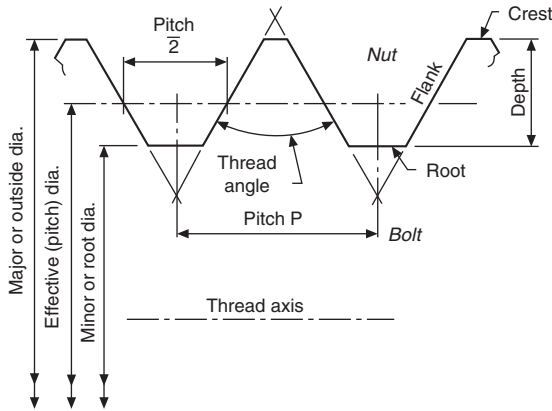


Fig. 17.2 External form to illustrate thread terms.

### ISO metric threads

Fig. 17.3 shows the ISO metric thread form for a nut (internal) and for a bolt (external). In the case of the nut, the root is rounded in practice. For the mating bolt, the crest of the thread may be rounded within the maximum outline, as shown, and the root radiused to the given dimension. Both male and female threads are subject to manufacturing tolerances and for complete information reference should be made to BS 3643-1.

BS 3643-2 defines two series of diameters with graded pitches for general use in nuts, bolts, and screwed fittings: one series with coarse and the other with fine pitches. The extract given in Table 17.1 from the Standard gives thread sizes from 1.6 to 24 mm diameter. Note that first, second, and third choices of basic diameters are quoted, to limit the number of sizes within each range.

On a drawing, a thread will be designated in accordance with BS EN ISO 6410-1, e.g. the letter M followed by the size of the nominal diameter, the pitch required, and the thread tolerance class, i.e.  $M10 \times 1 - 6h$ . The pitch is always preceded by a multiplication symbol and the tolerance class is always preceded by a short dash.

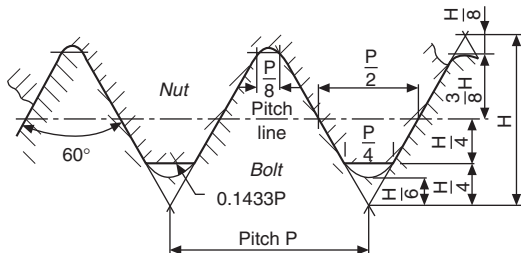


Fig. 17.3 ISO metric thread  $H = 0.86,603 P$ ,  $H/4 = 0.21,651 P$ ,  $(3/8)H = 0.32,476 P$ ,  $(5/8)H = 0.54,127 P$ , where  $P$  is the pitch of the thread.

**Table 17.1** Thread sizes from 1.6 to 24 mm diameter.

1	2	3	4	5	6	7	8	9	10	11	12	13	14	15	16
Basic major diameters choice			Coarse series with graded pitches	Fine series with constant pitches											
1st	2nd	3rd		6	4	3	2	1.5	1.25	1	0.75	0.5	0.35	0.25	0.2
1.6	—	—	0.35	—	—	—	—	—	—	—	—	—	—	—	0.2
—	1.8	—	0.35	—	—	—	—	—	—	—	—	—	—	—	0.2
2	—	—	0.4	—	—	—	—	—	—	—	—	—	—	0.25	—
—	2.2	—	0.45	—	—	—	—	—	—	—	—	—	—	0.25	—
2.5	—	—	0.45	—	—	—	—	—	—	—	—	—	0.35	—	—
3	—	—	0.5	—	—	—	—	—	—	—	—	—	0.35	—	—
—	3.5	—	0.6	—	—	—	—	—	—	—	—	—	0.35	—	—
4	—	—	0.7	—	—	—	—	—	—	—	—	0.5	—	—	—
—	4.5	—	0.75	—	—	—	—	—	—	—	—	0.5	—	—	—
5	—	—	0.8	—	—	—	—	—	—	—	—	0.5	—	—	—
—	—	5.5	—	—	—	—	—	—	—	—	—	0.5	—	—	—
6	—	—	1	—	—	—	—	—	—	—	0.75	—	—	—	—
—	—	7	1	—	—	—	—	—	—	—	0.75	—	—	—	—
8	—	—	1.25	—	—	—	—	—	—	—	0.75	—	—	—	—
—	—	9	1.25	—	—	—	—	—	—	1	0.75	—	—	—	—
10	—	—	1.5	—	—	—	—	—	1.25	1	0.75	—	—	—	—
—	—	11	1.5	—	—	—	—	—	—	1	0.75	—	—	—	—

*Continued*

**Table 17.1** Thread sizes from 1.6 to 24 mm diameter.—cont'd

1	2	3	4	5	6	7	8	9	10	11	12	13	14	15	16
Basic major diameters choice			Coarse series with graded pitches	Fine series with constant pitches											
1st	2nd	3rd		6	4	3	2	1.5	1.25	1	0.75	0.5	0.35	0.25	0.2
12	—	—	1.75	—	—	—	—	1.5	1.25	1	—	—	—	—	—
—	14	—	2	—	—	—	—	1.5	1.25 <sup>a</sup>	1	—	—	—	—	—
—	—	15	—	—	—	—	—	1.5	—	1	—	—	—	—	—
16	—	—	2	—	—	—	—	1.5	—	1	—	—	—	—	—
—	—	17	—	—	—	—	—	1.5	—	1	—	—	—	—	—
—	18	—	2.5	—	—	—	2	1.5	—	1	—	—	—	—	—
20	—	—	2.5	—	—	—	2	1.5	—	1	—	—	—	—	—
—	22	—	2.5	—	—	—	2	1.5	—	1	—	—	—	—	—
24	—	—	3	—	—	—	2	1.5	—	1	—	—	—	—	—

<sup>a</sup>The pitch of 1.25 mm for 14 mm diameter is to be used only for sparking plugs.

When dimensioning metric coarse threads it is not necessary to indicate the pitch as this is the default thread system. Should the reader encounter threads designated this way, e.g. M10 or M10 – 6H, it can be assumed they are of the coarse series. However, the authors advise that for completeness the pitch should always be included.

Any dimension relating to the depth or length of thread refers to the full depth or length of thread. The direction of a Right Hand thread (RH) is not generally noted; however Left Hand threads should include abbreviation ‘LH’ after the thread designation, i.e. M10 × 1 – 6h LH.

BS 3643-2 specifies the tolerances and limits of size for the tolerance classes 4H, 5H, 6H, and 7H for internal threads and 4h, 5h, 6h, and 7h for external threads. For general use, the tolerance class 6H is suitable for internal threads and tolerance class 6g for external threads.

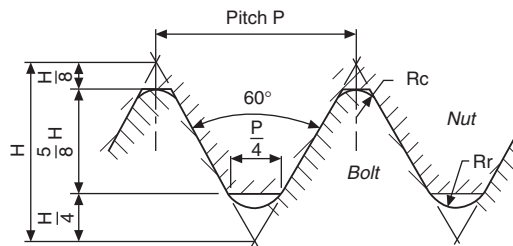
## Unified threads

The Unified system of screw threads was introduced by the United Kingdom, Canada, and the United States to provide a common standard thread for use by the three countries. The International Standards Organization (ISO) recommends the system as an international system of screw threads in inch units, in parallel with a similar system in metric units. Both of these systems use a similar form of thread profile, which is illustrated basically in Fig. 17.4.

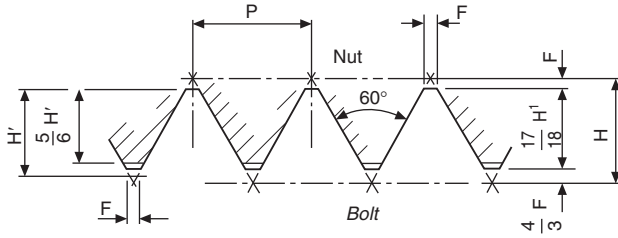
Unified threads are covered by BS 1580. Types in common use include the following:

- (a) UNC – a Unified coarse pitch thread, with progressive pitch sizes (i.e. the pitch varies with the diameter);
- (b) UNF – a Unified fine pitch thread, also with progressive pitch sizes;
- (c) UN – a Unified thread with a constant pitch (e.g. an 8 UN thread has eight threads to the inch regardless of the diameter).

Different classes of fit are obtainable by manufacture within alternative tolerance ranges and these are specified in BS 1580. Normally the same class of internal and external thread are used together.



**Fig. 17.4** Unified screw thread  $H = 0.86,603 P$ ,  $R_c = 0.108 P$ , and  $R_r = 0.144 P$ , where  $P$  is the pitch of the thread.



**Fig. 17.5** Sellers or American thread  $H = 0.866 P$ ,  $H' = 0.6495 P$ ,  $F = 0.1083 P = H'/8 = H'/6$ .

*Sellers or American thread* (Fig. 17.5). This type was the American National thread in common use before the introduction of the Unified National thread, as it is described in the USA and Canada, or the Unified screw-thread in Great Britain.

*Whitworth thread* (Fig. 17.6). The general shape of the thread shown has been used in a standard BSW (British Standard Whitworth) thread, in fine form as the BSF (British Standard Fine) thread, and as a pipe thread in the BSP (British Standard Pipe) thread.

The *British Standard Whitworth* thread was the first standardized British screw-thread.

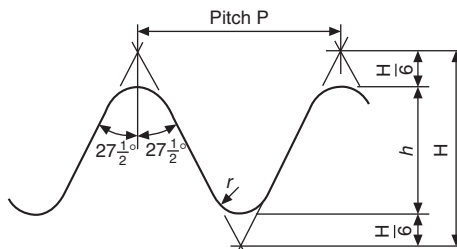
The *British Standard Fine* thread is of Whitworth section but of finer pitch. The reduction in pitch increases the core diameter; also, small adjustments of the nut can easily be made.

The *British Standard Pipe* threads are used internally and externally on the walls of pipes and tubes. The thread pitch is relatively fine, so that the tube thickness is not unduly weakened.

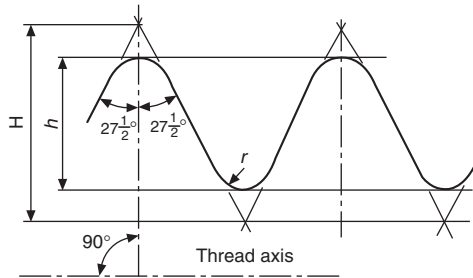
Pipe threads are covered by BS 21, which was adopted as the basis for ISO 7/1 where the metric values were conversions of the inch values, to obtain interchangeability.

The basic forms of the British Standard taper and parallel pipe threads are based on that of the British Standard Whitworth thread.

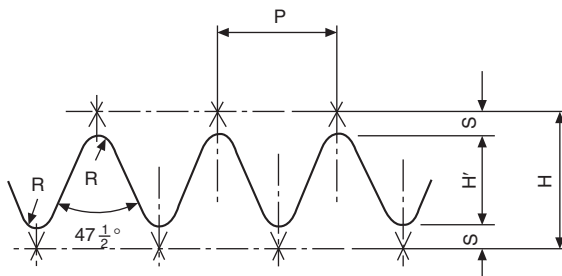
The Whitworth thread form is shown in Fig. 17.6. The thread angle of  $55^\circ$  is measured in an axial plane section; also the vee-section is truncated, at top and bottom, by one-sixth, with crest and root rounded by equal circular arcs. The theoretical thread



**Fig. 17.6** Basic Whitworth form  $H = 960,491 P$ ,  $h = 0.640,327 P$ ,  $r = 0.137,329 P$ .



**Fig. 17.7** Basic Whitworth form of taper pipe thread  $H = 0.960,273 P$ ,  $h = 0.640,327 P$ ,  $r = 0.137,278 P$ .



**Fig. 17.8** British Association (BA) thread  $H = 1.1363 P$ ,  $H' = 0.6 P$  (approx.),  $R = 0.18 P$ ,  $S = 0.268 P$ .

depth is shown as  $h = 0.640,327 P$  where  $P$  is the thread pitch. In the taper pipe thread (Fig. 17.7), a taper of 1 in 16 is used, measured on diameter.

British Association thread (Fig. 17.8). Generally used in sizes of less than  $\frac{1}{4}$  in. on small mechanisms. This range of threads extends down to a thread size of 0.25 mm and is covered by BS 93.

*Note:* BS 93 is an 'obsolescent' Standard. The Standard is not recommended for the design of new equipment, but is retained to provide a Standard for servicing equipment in use which is expected to have a long working life.

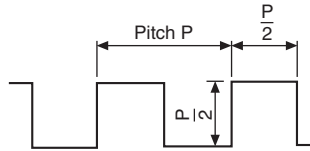
BS 4827 specifies the requirements for ISO miniature screw threads from 0.30 to 1.4 mm diameter with  $60^\circ$  form and are used in delicate instruments and watch making.

## Threads for power transmission

### Square thread (Fig. 17.9)

Used to transmit force and motion since it offers less resistance to motion than 'V' thread forms.

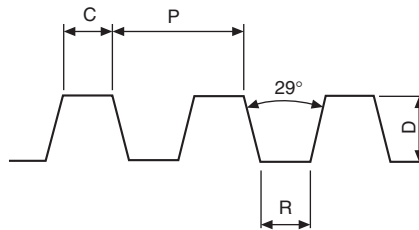
Widely used on lathes, this thread form is sometimes slightly modified by adding a small taper of about  $5^\circ$  to the sides as an aid to production.



**Fig. 17.9** Square Thread.

### **Acme thread (Fig. 17.10)**

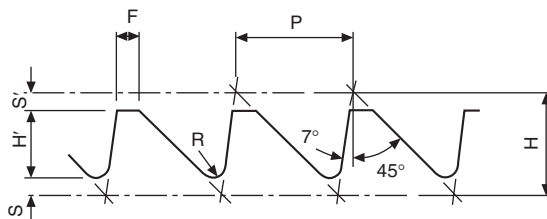
More easily produced than the square thread and often used in conjunction with split nuts for engagement purposes. It is applied in valve operating spindles.



**Fig. 17.10** Acme thread  $C = 0.3707 P$ ,  $R = C$ ,  $D = (P/2) + 0.01$ .

### **Buttress thread (Fig. 17.11)**

Used for transmitting power in one direction only. In its original form, the pressure face now sloping at  $7^\circ$  was perpendicular with the thread axis. A common application of the thread can be found in workshop vices.



**Fig. 17.11** Buttress thread  $H = 0.8906 P$ ,  $H' = 0.5058 P$ ,  $S = 0.1395 P$ ,  $S' = 0.245 P$ ,  $F = 0.2754 P$ ,  $R = 0.1205 P$ .

## Draughting conventions associated with threads

Threads are so regularly used on engineering drawings that recognizable conventions are required to save draughting time. Fig. 17.12 shows the convention for a male thread. The thread runout along the shank of the stud is indicated by a line drawn at  $30^\circ$  to the thread axis. The minor diameter of the thread is shown by parallel lines and in the end elevation the projected circle is not continuous. The break in the inside circle distinguishes the end elevation of a male thread from a female thread. Line thicknesses are given for each part of the thread. The actual dimensions of the minor diameter for any particular thread size can be approximated at 80% of the major diameter for the purposes of conventional representation.

Fig. 17.13 shows the convention for a female thread applied to a blind tapped hole in a sectional view. Note that the minor diameter is drawn as a complete circle in the end elevation and the major diameter is broken, and that the different line thicknesses also help to distinguish the female from the male thread. The effective length of the thread is again shown by parallel lines and the runout by the taper at  $30^\circ$  to the thread

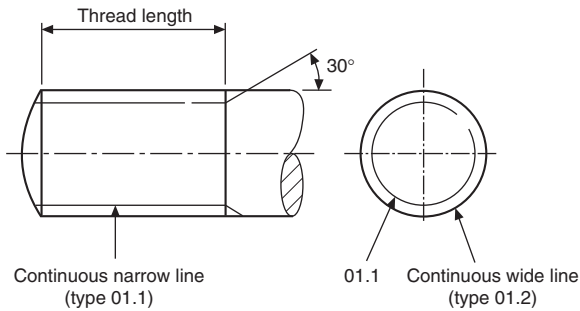


Fig. 17.12 Drawing convention for a male thread.

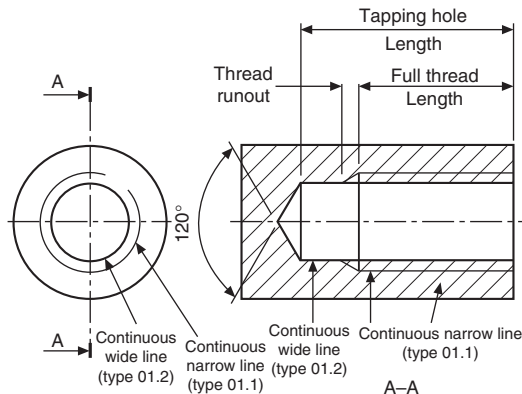


Fig. 17.13 Drawing convention for a female thread.

axis. In the sectional elevation, the section lines drawn at  $45^\circ$  continue through the major to the minor diameter. The included angle left by the tapping drill is  $120^\circ$ . Line thicknesses are indicated in the circles.

*Note:* The line at  $30^\circ$  indicating the runout was common practice. However, it is permitted to omit the line if there is no functional need for it. The tapered lines for incomplete threads are shown here for completeness of text.

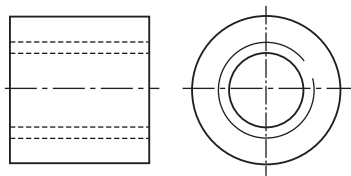
A female thread through a collar is shown in Fig. 17.14. Note that the projection of the major and minor diameters drawn as hidden detail will be indicated by dashed narrow lines.

A section through the collar is given in Fig. 17.15. The projection of the major diameter is drawn by a continuous narrow line and the cross hatching extends to the minor diameter.

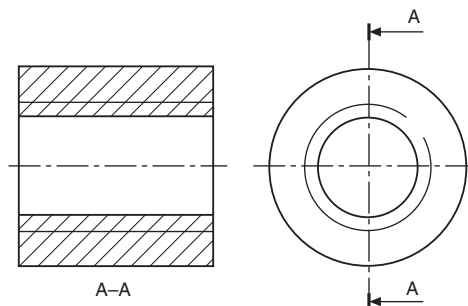
A section through a sealing cap in Fig. 17.16 illustrates a typical application where an internal thread terminates in an undercut.

Screw threads are produced by cutting or rolling. A cut thread can be made by the use of a tap for female threads, or a die in the case of a male thread. Fig. 17.17 shows a male thread cut by a die and terminating in a runout. In this application, the bar diameter has been drawn equal in size with the major diameter of the thread.

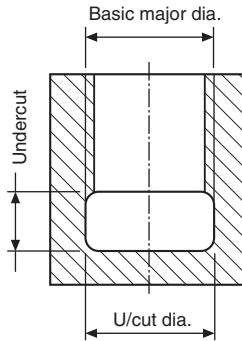
Screwcutting may be undertaken on the lathe and the cutting tool is shaped to match the thread angle. Generally the thread terminates in an undercut and this feature is illustrated in Fig. 17.18. It is a normal draughting practice to draw an undercut in line with the minor diameter of the thread. Too narrow an undercut or the demand for perfect or



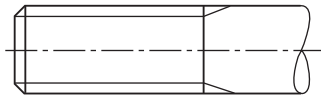
**Fig. 17.14** Female thread in hidden detail.



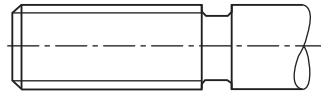
**Fig. 17.15** Female thread in section.



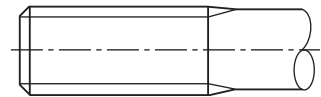
**Fig. 17.16** Female thread with undercut.



**Fig. 17.17** Die cut male thread.



**Fig. 17.18** Machine cut male thread with undercut.



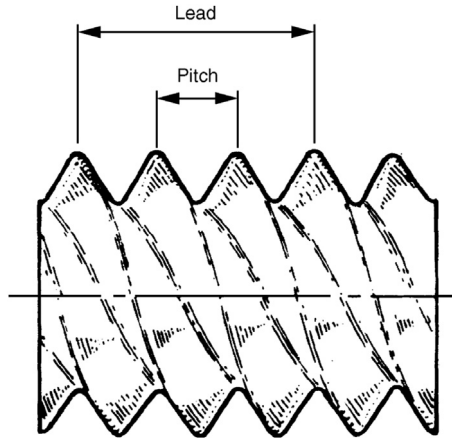
**Fig. 17.19** Rolled male thread.

full threads up to shoulders, or to the bottom of blind holes, increases manufacturing costs.

A rolled thread application is indicated in [Fig. 17.19](#). The thread is formed by deformation and runs out to a bar diameter which is approximately equal to the effective diameter of the thread.

## Multiple threads

Generally, screws have single threads and unless it is designated otherwise, it is fair to assume that a thread will be single. This means that the thread is formed from one continuous helix. The lead of a thread is the distance moved by a mating nut in one complete revolution of the nut. In a single thread the lead is equal to the pitch.



**Fig. 17.20** Pictorial view of a triple start thread.

When a two start thread is manufactured, there are two continuous helices and to accommodate the grooves, the lead is twice the thread pitch. Multiple threads are used where a quick axial movement is required with a minimum number of turns.

Now the standard drawing conventions do not differentiate between single and multiple threads. Details of the thread must be quoted with the drawing dimensions.

A triple start right-hand thread is shown in [Fig. 17.20](#).

## The application of thread conventions

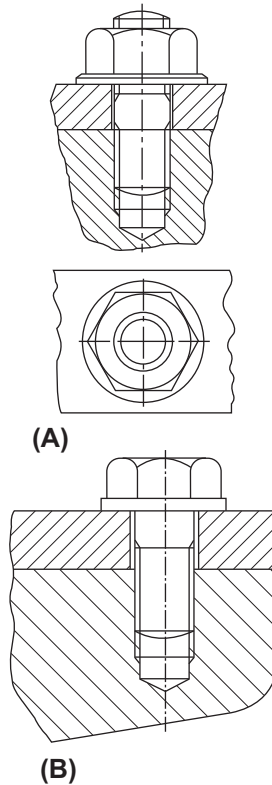
[Fig. 17.21A](#) shows an elevation of a stud in a tapped hole. When a mating thread is screwed into a tapped hole, the section lines do not cover the assembled threads; also, the threads on the stud terminate at the start of the hole to signify that the stud is screwed to maximum depth. Adjacent parts in the sectional view are cross hatched in opposite directions. It is not a normal practice to section nuts, bolts, and washers.

*Exercise* — Draw a similar assembly using an M24 stud. The stud is screwed for 30 mm into the tapped hole and the thickness of the component with the clearance hole is 25 mm. Use Table 18.1 for other dimensions and assume proportions of unimportant detail.

[Fig. 17.21B](#) shows part of a component which is held by a set-bolt in a tapped hole. Only part of the shank of the bolt is threaded and this must terminate above the joined line between the components for correct assembly.

*Exercise* — Draw a similar arrangement using an M20 set-bolt which engages with the tapped thread for a length of 25 mm. Component thickness is 22 mm. Assume other dimensions.

*Note:* The thickness of a nut is slightly greater than the thickness of a bolthead. For approximate constructions of a bolthead, use a thickness of  $0.7 D$ , where  $D$  is the shank diameter.



**Fig. 17.21** Drawing convention for mating threads.

## Tapping drill

The diameter of a tapping drill is equal to the minor diameter of a thread to be tapped for drawing purposes. The function of a tapping drill is to remove the bulk of the material for a female thread, leaving the tap to cut only the thread form between the major and minor diameters.

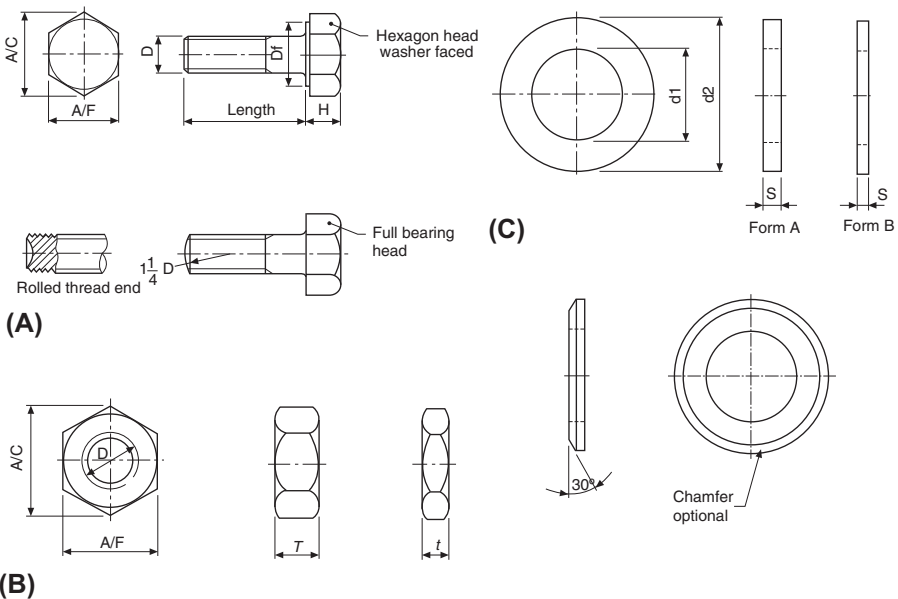
## Clearance drill

A clearance drill has a diameter slightly greater than the major diameter of a male thread and its function is to provide a clearance hole to permit the free passage of a bolt through a component.

ISO metric precision hexagon bolts, screws, and nuts are covered by BS 3643 and ISO 272. The Standard includes washer faced hexagon head bolts and full bearing head bolts. In both cases there is a small radius under the bolthead which would not normally be shown on drawings, due to its size, but is included here for completeness of the text. With an M36 bolt, the radius is only 1.7 mm. Bolts may be chamfered at 45° at the end of the shank, or radiused. The rounded end has a radius of approximately one and one-quarter times the shank diameter and can also be used if required to draw the rolled thread end. The washer face under the head is also very thin and for an M36 bolt is only 0.5 mm.

Fig. 18.1A shows the bolt proportions and Table 18.1 the dimensions for bolts in common use. Dimensions of suitable nuts are also given and illustrated in Fig. 18.1B.

Included in Table 18.1 and shown in Fig. 18.1C are typical washers to suit the above bolts and nuts and these are covered by BS 4320. Standard washers are available in two different thicknesses, in steel or brass, and are normally plain, but may be chamfered.



**Fig. 18.1** Proportions of bolts, nuts and washers.  $A/C$  means across corners.  $A/F$  means across flats. (A) Hexagon head precision bolts. (B) Precision nuts and thin nuts. (C) Bright washers.

**Table 18.1** Dimensions of commonly used bolts, nuts and washers.

Nominal size thread diameter $D$	Thread pitch	Minor diameter of thread	Width across corners (A/ C)	Width across flats (A/F)	Diameter of washer face $D$	Height bolt head $H$	Thickness of normal nut $T$	Thickness of thin nut $t$	Washer inside diameter	Washer outside diameter	Washer thickness form A	Washer thickness form B
M1.6	0.35	1.1	3.5	3.01.0	1.251.7	4.0	0.3					
M2	0.4	1.4	4.5	4.01.5	1.52.2	5.0	0.3					
M2.5	0.45	1.9	5.5	5.01.75	2.02.7	6.5	0.5					
M3	0.5	2.3	6.0	5.5	5.0	2.0	2.253.2	7.0	0.5			
M4	0.7	3.0	8.0	7.0	6.5	2.75	3.04.3	9.0	0.8			
M5	0.8	3.9	9.0	8.0	7.5	3.5	4.05.3	10.0	1.0			
M6	1.0	4.7	11.5	10.0	9.0	4.0	5.06.4	12.5	1.6	0.8		
M8	1.25	6.4	15.0	13.0	12.0	5.5	6.5	5.0	8.4	17	1.6	1.0
M10	1.5	8.1	19.5	17.0	16.0	7.0	8.0	6.0	10.5	21	2.0	1.25
M12	1.75	9.7	21.5	19.0	18.0	8.0	10.0	7.0	13.0	24	2.5	1.6
M16	2.0	13.5	27.0	24.0	23.0	10.0	13.0	8.0	17.0	30	3.0	2.0
M20	2.5	16.7	34.0	30.0	29.0	13.0	16.0	9.0	21.0	37	3.0	2.0
M24	3.0	20.0	41.5	36.0	34.5	15.0	19.0	10.0	25.0	44	4.0	2.5
M30	3.5	25.5	52.0	46.0	44.5	19.0	24.0	12.0	31.0	56	4.0	2.5
M36	4.0	31.0	62.5	55.0	53.5	23.0	29.0	14.0	37.0	66	5.0	3.0

Table 18.1 gives dimensions of commonly used bolts, nuts, and washers so that these can be used easily on assembly drawings. For some dimensions maximum and minimum values appear in the Standards and we have taken an average figure rounded up to the nearest 0.5 mm and this will be found satisfactory for normal drawing purposes. Reference should be made to the relevant Standards quoted for exact dimensions if required in design and manufacture.

## Drawing nuts and bolts

It is often necessary to draw nuts and bolts, and a quick and easy method is required to produce a satisfactory result.

Nuts and bolts are not normally drawn on detail drawings unless they are of a special type. They are shown on assembly drawings and, provided they are standard stock sizes, are called up in parts lists and schedules. A description of the head, the thread and the length are generally sufficient. Templates are available for drawing nuts and bolts and can be recommended for their time saving advantages.

It is conventional drawing practice to show, as first choice, nuts and bolts in the across corners position if a single view only is illustrated since this is instantly recognizable.

## Approximate construction for nuts and bolts (Figs. 18.2 and 18.3)

### Stage 1

1. Draw a circle in the plan position,  $2D$  in diameter, where  $D$  is equal to the thread size. In this example let us assume that the thread size is M20.
2. Draw a hexagon inside the 40 mm diameter circle and inside the hexagon draw another circle tangential to the hexagon on the six sides. This circle is the projection of the chamfer which can be seen on the front elevation.

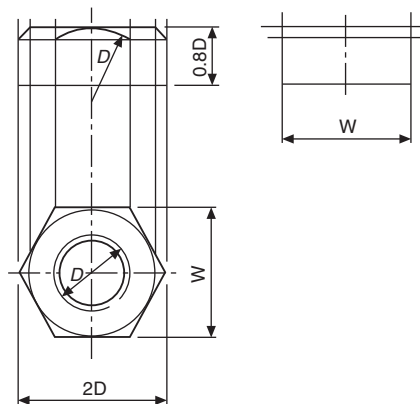
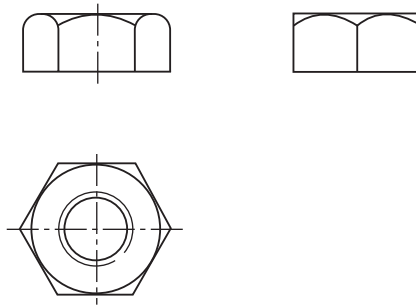


Fig. 18.2 Stage 1.



**Fig. 18.3** Stage 2.

3. The nut thickness is  $0.8 D$ . Project the four corners of the hexagon to the front elevation.
4. Project three corners of the hexagon in the end elevation and note that the width of the end elevation is given by dimension  $W$ .
5. Line in the projected diameter of the chamfer circle and the base on the front elevation.
6. As an approximation, draw a radius to show the chamfer on the front elevation. The radius should equal the thread size  $D$ .
7. Add the female convention to the plan view.

### Stage 2

1. The projection of the curve on the chamfered faces of the hexagon that lie at an angle would produce ellipses in the front elevation. In their place we usually show small circular arcs; their radii can be found by trial, but are approximately  $0.25 D$ .
2. The end elevation of the nut has square corners and the projection of the corner which coincides with the center line terminates at the bottom of the chamfer curve.
3. Complete the view by drawing circular arcs on the two chamfered faces. Find, by trial, the radius of an arc which will touch the top of the nut and the projection lines from the corner in the front elevation.

Reference to [Fig. 18.1A and B](#) will show that the constructions in [Figs. 18.2 and 18.3](#) can be used for the bolthead and locknut where proportions for thickness can be approximated to  $0.7 D$  and  $0.5 D$ .

For exact dimensions however, please refer to [Table 18.1](#).

## Socket head screws manufactured to BS EN ISO 4762 and BS 3643-2

It is often required to draw these screws and although the head type and the length are generally quoted in parts lists it is necessary to know the proportions of the head. Dimensions follow for each of the most commonly used screws.

Before specifying screws, it is advisable to consult a manufacturers' list for availability. In the interest of standardization and economy, designers are urged to use stock

lengths wherever possible and standard lengths of screws include the following: 3, 4, 5, 6, 8, 10, 12, 16, 20, 25, 30, 35, 40, 45, 50, 55, 60, 65, 70, 75, 80, 90, 100, 110, 120, 130, 140, 150, 160, 170, 180, 190, and 200 mm. If lengths over 200 mm are required, then increments of 20 mm are the preferred ISO lengths. It should be understood that not all diameters of screw are available in the above lengths. For example, the range of lengths for an M3 screw lies between 5 and 35 mm, and for an M10 screw between 12 and 100 mm for one particular type of head. The same range will also not cover different types of head, hence the necessity to check stock lists (Fig. 18.4).

### ISO metric hexagon socket cap screws (dimensions in Table 18.2)

These screws are distinguished by square knurling on the heads. Generally, the lengths of standard screws increase in increments of 5 and 10 mm, but the exact range should be checked from the manufacturer's catalog.

### ISO metric hexagon socket shoulder screws (dimensions in Table 18.3)

See Fig. 18.5.

### ISO metric hexagon socket button head screws (dimensions in Table 18.4)

See Fig. 18.6.

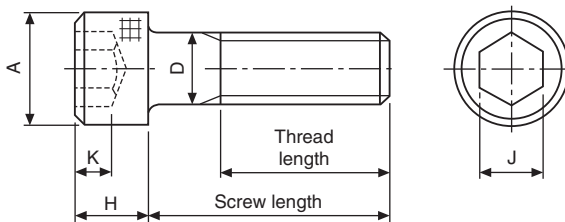


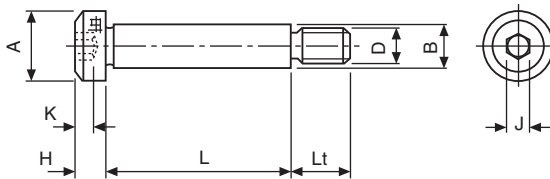
Fig. 18.4 ISO metric hexagon socket cap screw. Dimensions in Table 18.2.

**Table 18.2** Dimensions of metric socket cap screws.

Nominal size $D$	M3	M4	M5	M6	M8	M10	M12	M16	M20
Head diameter $A$	5.5	7	8.5	10	13	16	18	24	30
Head depth $H$	3	4	5	6	8	10	12	16	20
Key engagement $K$	1.3	2	2.7	3.3	4.3	5.5	6.6	8.8	10.7
Socket size $J$	2.5	3	4	5	6	8	10	14	17

**Table 18.3** Dimensions of metric hexagon socket shoulder screws.

Screw thread diameter $D$	M5	M6	M8	M10	M12
Nominal shoulder diameter $B$	6	8	10	12	16
Head diameter $A$	10	13	16	18	24
Head height $H$	4.5	5.5	7	8	10
Socket size $J$	3	4	5	6	8
Nominal thread length $L$	9.75	11.25	13.25	16.4	18.4
Key engagement $K$	2.45	3.3	4.15	4.92	6.62

**Fig. 18.5** ISO metric hexagon socket shoulder screws. Dimensions in [Table 18.3](#).**Table 18.4** Dimensions of metric socket button head screws.

Nominal size $D$	M3	M4	M5	M6	M8	M10	M12
Head diameter $A$	5.5	7.5	9.5	10.5	14	18	21
Head depth $H$	1.6	2.1	2.7	3.2	4.3	5.3	6.4
Key engagement $K$	2	2.5	3	4	5	6	8
Socket size $J$	1.04	1.3	1.56	2.08	2.6	3.12	4.16
<b>Fillet radius</b>							
$F$ —minimum	0.1	0.2	0.2	0.25	0.4	0.4	0.6
$d$ —maximum	3.6	4.7	5.7	6.8	9.2	11.2	14.2
S	0.38	0.38	0.5	0.8	0.8	0.8	0.8

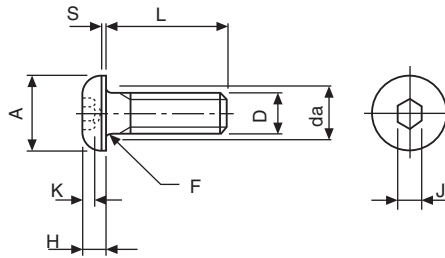


Fig. 18.6 ISO metric hexagon socket button head screws. Dimensions in Table 18.4.

## ISO metric hexagon socket countersunk head screws (dimensions in Table 18.5)

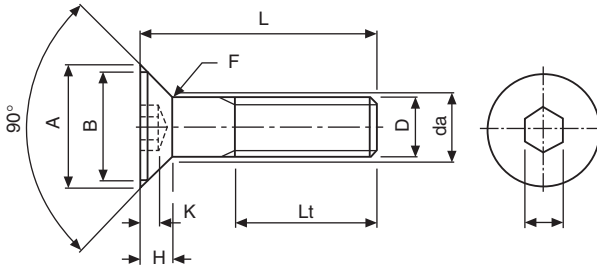
The basic requirement for countersunk head screws is that the head should fit into a countersunk hole with as great a degree of flushness as possible. Fig. 18.7 and Table 18.5 give dimensions. To achieve this it is necessary for both the head of the screw and the countersunk hole to be controlled within prescribed limits. The maximum or design size of the head is controlled by a theoretical diameter to a sharp corner and the minimum head angle of  $90^\circ$ . The minimum head size is controlled by a minimum head diameter, the maximum head angle of  $92^\circ$  and a flushness tolerance. The edge of the head may be flat, as shown in Fig. 18.8, or rounded but not sharp edged (see below).

## ISO metric hexagon socket set screws (dimensions in Table 18.6)

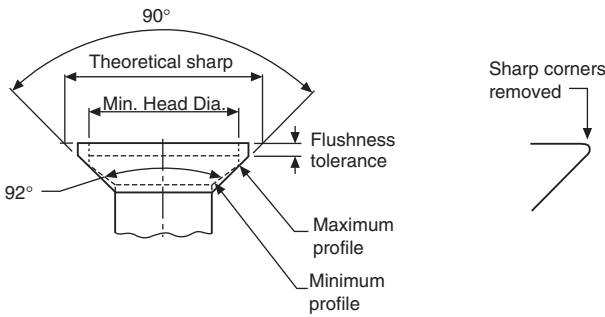
These screws are available with a variety of pointed ends. In all cases the overall length includes the chamfer at the socket end and the point.

Table 18.5 Dimensions of metric hexagon socket countersunk head screws.

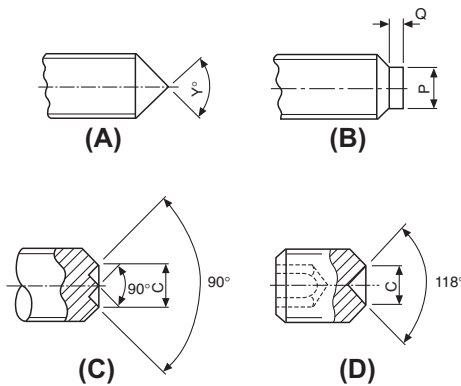
Nominal size $D$	M3	M4	M5	M6	M8	M10	M12	M16	M20
<b>Head diameter</b>									
$A$ – maximum	6.72	8.96	11.2	13.44	17.92	22.4	26.88	33.6	40.32
$B$ – minimum	5.82	7.78	9.78	11.73	15.73	19.67	23.67	29.67	35.61
Head depth $H$	1.86	2.48	3.1	3.72	4.96	6.2	7.44	8.8	10.16
Socket size $J$	2	2.5	3	4	5	6	8	10	12
Key engagement $K$	1.05	1.49	1.86	2.16	2.85	3.60	4.35	4.89	5.49
<b>Fillet radius</b>									
$F$ – minimum	0.1	0.2	0.2	0.25	0.4	0.4	0.6	0.6	0.8
$d$ – maximum	3.4	4.5	5.5	6.6	9	11	14	18	22



**Fig. 18.7** ISO metric hexagon socket countersunk head screws, Dimensions in [Table 18.5](#).



**Fig. 18.8** ISO metric hexagon socket countersunk head screws, head details. Dimensions in [Table 18.5](#).



**Fig. 18.9** ISO metric hexagon socket set screws (A) Cone point (B) Dog point (C) W point (D) Cup point. Dimensions in [Table 18.6](#).

**Table 18.6** Dimensions of metric hexagon socket set screws.

Nominal size <i>D</i>	M3	M4	M5	M6	M8	M10	M12	M16	M20
Socket size <i>J</i>	1.5	2	2.5	3	4	5	6	8	10
Key engagement <i>K</i>	1.2	1.6	2	2.4	3.2	4	4.8	6.4	8
Dog point diameter <i>P</i>	2	2.5	3.5	4.5	6	7	9	12	15
Dog point length <i>Q</i>	0.88	1.12	1.38	1.62	2.12	2.62	3.12	4.15	5.15
Cup point and 'W' point diameter <i>C</i>	1.4	2	2.5	3	5	6	8	10	14

## Machine screws

Head shapes for machine screws have been rationalized in BS EN ISO 1580 and BS EN ISO 7045. For the purpose of this British Standard, the generic term *screws* applies to products which are threaded up to the head or having an unthreaded portion of the shank.

The length of the thread is defined as the distance from the end of the screw, and this includes any chamfer, radius or cone point, to the leading face of the nut which has been screwed as far as possible onto the screw by hand. Note on the illustrations which follow that in the case of the countersunk head types of screw, the length of the screw includes the countersunk part of the head. For pan and cheese head screws, the screw length does not include the head.

The Standard should be consulted for manufacturing dimensional tolerances, and also for concentricity tolerances for the heads of the screws.

The illustrations which follow show each of the screws and tables are also given showing the dimensions of regularly used sizes.

The sizes quoted in the tables are for screws manufactured in steel. Standard screws are also available in brass but generally the range is not quite so extensive.

For all of the machine screws illustrated here, the countersunk head types have an included angle of 90° (Figs. 18.9–18.17).

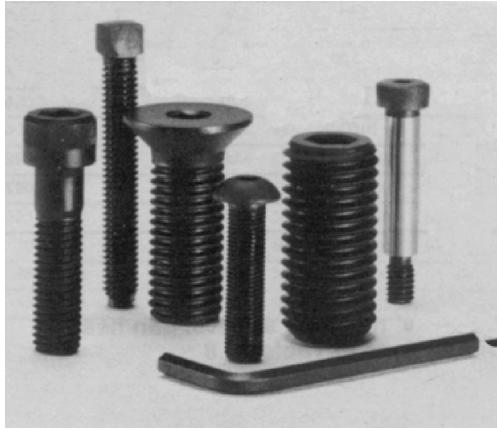
'Posidriv' Machine Screws, Countersunk and Raised Countersunk Head (Dimensions in Table 18.7).

'Posidriv' Machine Screws, Pan Head (Dimensions in Table 18.8).

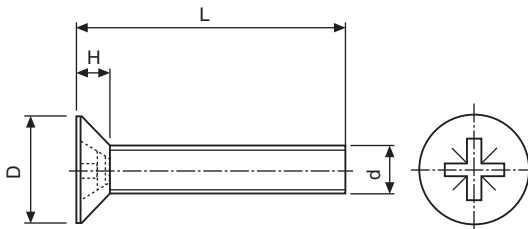
Slotted Machine Screws, Countersunk and Raised Countersunk Head (Dimensions in Table 18.9).

Slotted Machine Screws, Pan Head (Dimensions in Table 18.10).

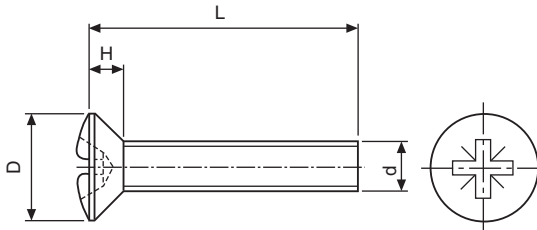
Slotted Machine Screws, Cheese Head (Dimensions in Table 18.11).



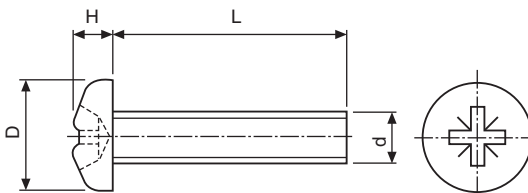
**Fig. 18.10** Typical socket screws and wrench.



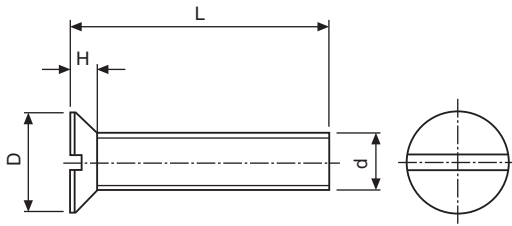
**Fig. 18.11** Countersunk head.



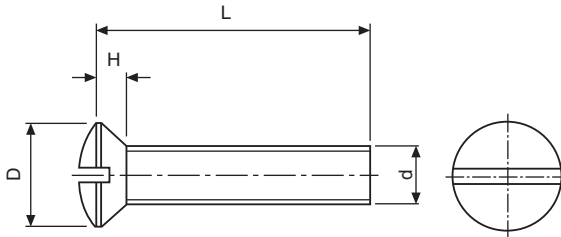
**Fig. 18.12** Raised countersunk head.



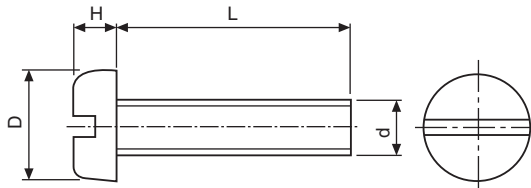
**Fig. 18.13** Pan head.



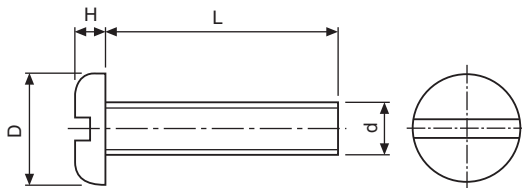
**Fig. 18.14** Countersunk head.



**Fig. 18.15** Raised countersunk head.



**Fig. 18.16** Pan head.



**Fig. 18.17** Cheese head.

## Machine screw nuts

A range of machine screw nuts is covered by BS EN ISO 1580 and BS EN ISO 7045 and these nuts are manufactured in two different patterns: square and hexagon. The relevant table shows typical nuts for use with the screws previously described (Table 18.12 and Figs. 18.18 and 18.19).

**Table 18.7** Dimensions of metric posidriv countersunk and raised countersunk head machine screws.

Diameter $d$	Diameter of head $D$	Depth of head $H$	Driver number	Length $L$												
M2	4.40	1.20	1	4	5	6	8	10	12							
M2.5	5.50	1.50	1	5	6	8	10	12	16	20	25					
M3	6.30	1.65	1	5	6	8	10	12	16	20	25					
M3.5	7.35	1.93	2	6	8	10	12	16	20	25	30					
M4	8.40	2.20	2	6	8	10	12	16	20	25	30					
M5	10.00	2.50	2	6	8	10	12	16	20	25	30	35	40	45	50	
M6	12.00	3.00	3	10	12	16	20	25	30	35	40	45	50	55	60	
M8	16.00	4.00	4	12	16	20	25	30	40	50	60					
M10	20.00	5.00	4	16	20	25	30	40	50	60						

**Table 18.8** Dimensions of metric posidriv pan head machine screws.

Diameter <i>d</i>	Diameter of head <i>D</i>	Depth of head <i>H</i>	Driver number	Length <i>L</i>												
M2	4.00	1.60	1	4	5	6	8	10	12							
M2.5	5.00	1.75	1	5	6	8	10	12	16	20	25					
M3	6.00	2.10	1	5	6	8	10	12	16	20	25					
M3.5	7.00	2.45	2	6	8	10	12	16	20	25	30					
M4	8.00	2.80	2	5	6	8	10	12	16	20	25	30				
M5	10.00	3.50	2	6	8	10	12	16	20	25	30	35	40	45	50	
M6	12.00	4.20	3	10	12	16	20	25	30	35	40	45	50	55	60	
M8	16.00	5.60	4	16	20	25	30	40	50							
M10	20.00	7.00	4	20	25	30	40									

**Table 18.9** Dimensions of slotted countersunk and raised countersunk machine screws.

Diameter $d$	Diameter of head $D$	Depth of head $H$	Length $L$														
M2	4.40	1.20	5	6	8	10	12										
M2.5	5.50	1.50	5	6	8	10	12	16	20	25							
M3	6.30	1.65	5	6	8	10	12	16	20	25	30	35	40	45	50		
M3.5	7.35	1.93	5	6	8	10	12	16	20	25	30	35	40	45	50	60	
M4	8.40	2.20	5	6	8	10	12	16	20	25	30	35	40	45	50	60	70
M5	10.00	2.50	6	8	10	12	16	20	25	30	35	40	45	50	60	70	80
M6	12.00	3.00	8	10	12	16	20	25	30	35	40	45	50	60	70	80	90
M8	16.00	4.00	10	12	16	20	25	30	35	40	45	50	60	70	80	90	
M10	20.00	5.00	16	20	25	30	35	40	45	50	55	60	70	80	90		

**Table 18.10** Dimensions of metric slotted pan head machine screws.

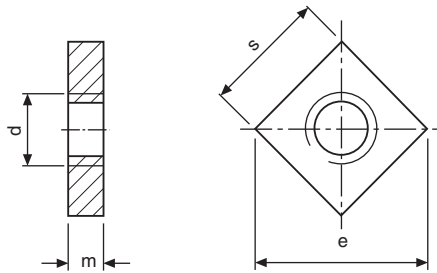
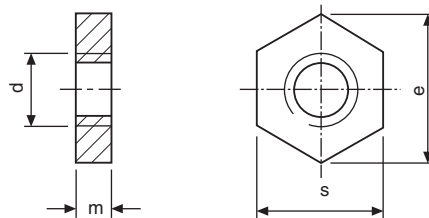
Diameter <i>d</i>	Diameter of head <i>D</i>	Depth of head <i>H</i>	Length <i>L</i>															
M2	4.00	1.20	4	5	6	8	10	12										
M2.5	5.00	1.50	5	6	8	10	12	16	20	25								
M3	6.00	1.80	5	6	8	10	12	16	20	25	30	35	40	45	50			
M3.5	7.00	2.10	6	8	10	12	16	20	25	30	35	40	45	50				
M4	8.00	2.40	5	6	8	10	12	16	20	25	30	35	40	45	50			
M5	10.00	3.00	6	8	10	12	16	20	25	30	35	40	45	50	55	60	70	80
M6	12.00	3.60	8	10	12	16	20	25	30	35	40	45	50	55	60	70	80	
M8	16.00	4.80	10	12	16	20	25	30	40	50	60	70	80	90				
M10	20.00	6.00	16	20	25	30	40	50	60	70								

**Table 18.11** Dimensions of metric slotted cheese head machine screws.

Diameter $d$	Diameter of head $D$	Depth of head $H$	Length $L$															
M2	3.80	1.30	3	4	5	6	8	10	12	16	20	25						
M2.5	4.50	1.60	5	6	8	10	12	16	20	25	30							
M3	5.50	2.00	4	5	6	8	10	12	16	20	25	30	35	40	45	50		
M3.5	6.00	2.40	5	6	8	10	12	16	20	25	30	35	40	45	50	60	70	
M4	7.00	2.60	5	6	8	10	12	16	20	25	30	35	40	45	50	60	70	
M5	8.50	3.30	6	8	10	12	16	20	25	30	35	40	45	50	60	70	80	90
M6	10.00	3.90	8	10	12	16	20	25	30	35	40	45	50	60	70	80	90	
M8	13.00	5.00	10	12	16	20	25	30	35	40	45	50	60	70	80	90		
M10	16.00	6.00	16	20	25	30	35	40	45	50	60	70	80	90				

**Table 18.12** Machine screw nuts, pressed type, square and hexagonal.

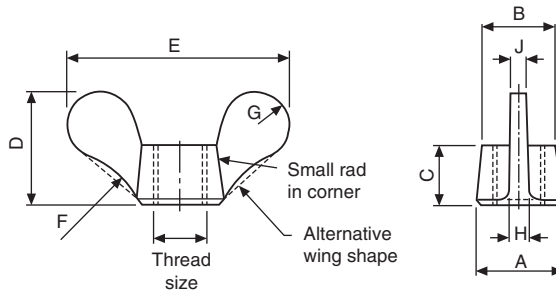
Nominal size of nut $d$	Width across flats $s$	Width across corners $e$		Thickness $M$
		Square	Hexagon	
M2	4.0	5.7	4.6	1.2
M2.5	5.0	7.1	5.8	1.6
M3	5.5	7.8	6.4	1.6
M3.5	6.0	8.5	6.9	2.0
M4	7.0	9.9	8.1	2.0
M5	8.0	11.3	9.2	2.5
M6	10.0	14.1	11.5	3.0
M8	13.0	18.4	15.0	4.0
M10	17.0	24.0	19.6	5.0

**Fig. 18.18** Square nut.**Fig. 18.19** Hexagon nut.

## Wing nuts

Fig. 18.20 shows the dimensions of preferred sizes of wing nuts manufactured in brass or malleable iron by a hot stamping or casting process (Table 18.13).

An alternative wing nut is available in brass or malleable iron and manufactured by cold forging.



**Fig. 18.20** Sizes are in [Table 18.13](#).

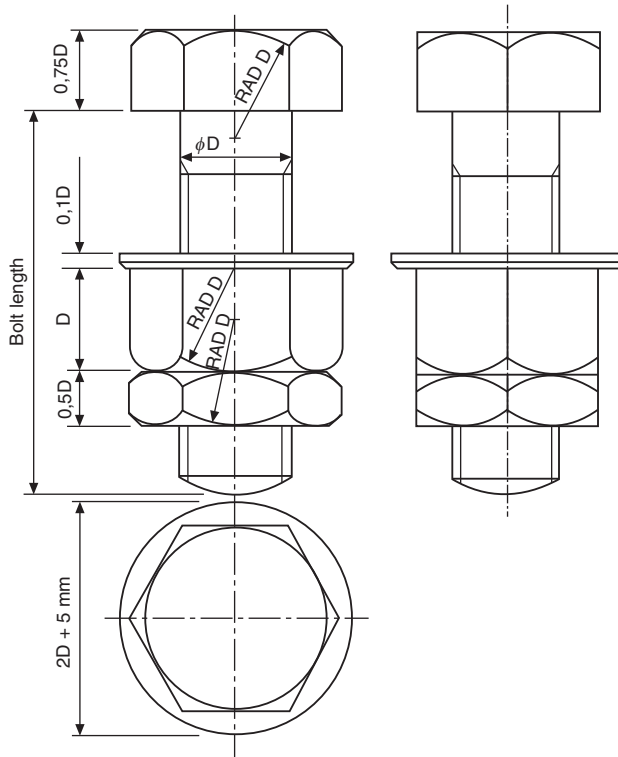
**Table 18.13** Dimensions of metric wing nuts.

Thread size	A	B	C	D	E	F	G	H	J
M3	9	6.5	7	13.5	22	19	3.5	2.5	1.5
M4 and M5	10	8	9	15	25.5	19	4	2.5	1.5
M6	13	9.5	11	18	30	19	5	2.5	1.5
M8	16	12	13	23	38	19	6.5	3	2.5
M10	17.5	14	14	25.5	44.5	19	7	5	3
M12	19	16	15	28.5	51	25.5	8	5	3
M16	25.5	20.5	19	36.5	63.5	32	10	6.5	5

## Locking and retaining devices

The function of a locking device is to prevent loosening or disengagement of mating components which may be operating under varying conditions of stress, temperature, and vibration. The effectiveness of the locking device might be vital to safety.

One of the simplest locking devices is a locknut and these are generally thin plain nuts which are tightened against ordinary plain nuts or against components into which male threaded items are assembled. To ensure efficient locking, the bearing surfaces of the nut and component must bed together evenly and the correct degree of tightness obtained by applying the designed torque loading. The locknut should not be overtightened as this may result in the stripping of the nut threads or overstressing of the male component. In cases where rotation can occur, the plain nut must be held stationary while the locknut is tightened ([Fig. 18.21](#)).



**Fig. 18.21** Bolts, nut, and locknut.

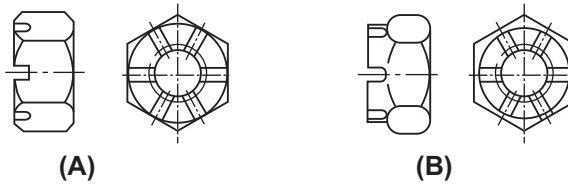
## Slotted nuts and castle nuts

One method of preventing nuts from coming loose is to drill the bolt and use a pin through the assembly. Suitable nuts are shown in [Fig. 18.22](#). Slotted nuts are available for sizes M4 to M39 and have six slots. Castle nuts are also available with six slots between sizes M12 to M39 and eight slots between sizes M42 and M68. For convenience in drawing both types of nuts, the total thickness can be approximated to the thread diameter plus 2 mm. The dimensions for the hexagons can be taken from [Table 18.1](#).

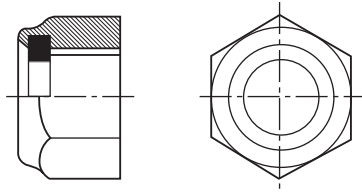
Slotted nuts are reusable but difficult to apply where access is limited.

## Simmonds locknut

This type of locknut incorporates a collar manufactured from nylon or fiber and the collar is slightly smaller in diameter than the internal thread diameter. The section in [Fig. 18.23](#) shows the collar in black. On assembly, the stud or bolt forces its way



**Fig. 18.22** (A) Slotted nut. (B) Castle nut.



**Fig. 18.23** Simmonds nut.

through the resilient collar which provides a frictional lock. The locknut is a little thicker than a conventional nut.

## Spring washers

This type of washer is produced as a single or a double coil spring. The cross-section is rectangular. Generally this type of washer dispenses with the simple plain washer although a plain washer can be used at the same time with assemblies where the component is manufactured from relatively soft-light alloys. The free height of double coil washers before compression is normally about five times the thickness of the steel section (Table 18.14 and Fig. 18.24).

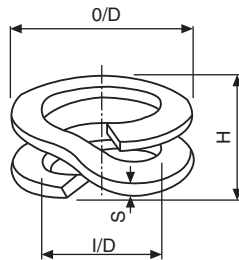
## Shakeproof washers

This type of washer is generally made from spring steel and serrations are formed on either the internal or external diameters. These serrations then bite into the pressure faces between the nut and the component when the nut is assembled. Some slight disfigurement of the component may result on assembly but this is of little significance except where anti-corrosion treatment of the component surface has previously been carried out. Some screws are pre-assembled with conical lockwashers which are free to rotate but do not come off (Fig. 18.25).

Toothed lockwashers combat vibration and are especially suited to rough parts or surfaces.

**Table 18.14** Double coil rectangular section spring washers to BS 4464.

Nominal thread diameter	Maximum inside diameter <i>I/D</i>	Maximum outside diameter <i>O/D</i>	Thickness <i>S</i>	Free height <i>H</i>
M2	2.4	4.4	0.50	2.50
M3	3.6	6.2	0.80	4.00
M4	4.6	8.0	0.80	4.00
M5	5.6	9.8	0.90	4.50
M6	6.6	12.9	1.00	5.00
M8	8.6	15.1	1.20	6.00
M10	10.8	18.2	1.20	6.00
M12	12.8	20.2	1.60	8.00
M16	17.0	27.4	2.00	10.00
M20	21.5	31.9	2.00	10.00
M24	26.0	39.4	3.25	16.25
M30	33.0	49.5	3.25	16.25
M36	40.0	60.5	3.25	16.25

**Fig. 18.24** Spring washer.

## Wire locking

Non-corrodible steel and brass wire, of the appropriate gauge, are normally used for wire locking. Generally, a hole is provided for this purpose in the component to be locked and the wire is passed through and twisted. The lay of the wire between the anchorage and the component must always be such as to resist any tendency of the locked part or parts to become loose.

Fig. 18.26 shows the plan view of a pressurized cylinder and the cover is held down by four bolts which are wire locked. The operation is performed with a single strand of

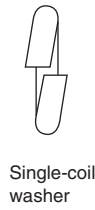
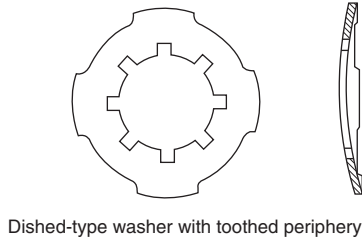
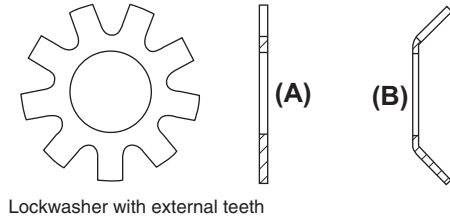


Fig. 18.25 Types of locking washer. (A) Flat form. (B) Dished type.

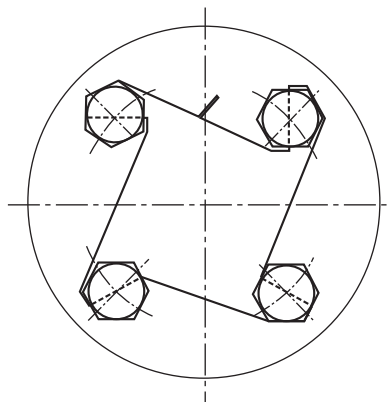


Fig. 18.26 Example of wire locking four bolts.

wire. The wire is passed in sequence through the holes in the bolts and the ends are twisted together to tension the wire loop. Note that in order to become loose, the bolts must turn in an anticlockwise direction but this will have the effect of increasing the tension in the wire loop. The locking wire should only be used once.

## Tab washers

Tab washers are thin metal washers designed with two or more tabs which project from the external diameter. On assembly, a tab is bent against the component or sometimes into a hole in the component. Other tabs are then bent up against the correctly tightened nut. Another pattern has a tab projecting from the inside diameter and this is intended to fit into a slot machined in the bolt, while the external tabs are again bent against the flat sides of the nut. The deformation of the tab washer is such that it is intended to be used only once.

Three different types of tab washer are shown in [Fig. 18.27](#), together with a typical assembly.

## Locking plates

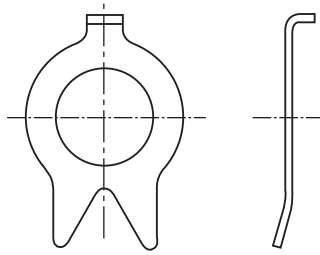
Locking plates are manufactured usually from mild steel and fit over hexagonal nuts after these have been tightened on assembly. The locking plate is then secured on the component by a separate screw which may itself be fitted with a shakeproof or spring type of washer.

Locking plates may be used repeatedly, provided they remain a good fit, around the hexagon of the nut or the bolthead. Locking plates may be cranked, as in [Fig. 18.28](#) or flat.

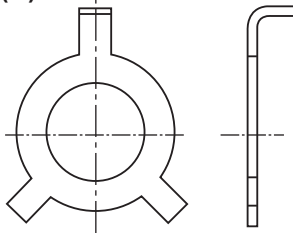
[Fig. 18.29](#) shows a selection of locking terminals where a 'shakeproof' washer and a soldering lug are combined into one unit, thus saving assembly time. The locking teeth anchor the terminal to the base to prevent shifting of the terminal in handling, while the twisted teeth produce a multiple bite which penetrates an oxidized or painted surface to ensure good conductivity. All three types of locking terminal are generally made from phosphor bronze with a hot-tinned finish.

## Taper pins and parallel pins

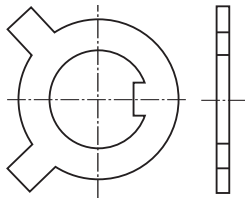
Taper pins, with a taper of 1 in 50, and parallel pins are used on both solid and tubular sections to secure, for example, levers to torque shafts and control rods to fork ends. Some taper pins are bifurcated, or split, and the legs can be opened out for locking. Plain taper pins and parallel pins may also be locked by peening. To prevent slackness,



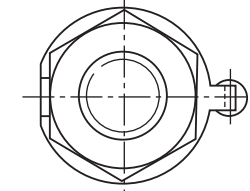
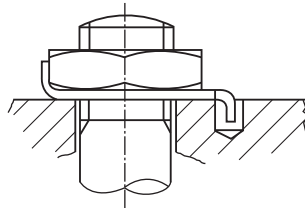
(A)



(B)

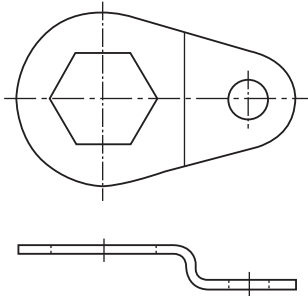


(C)

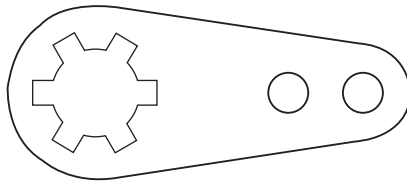


(D) Tab washer assembly

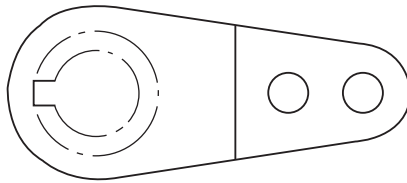
Fig. 18.27 Examples of tab washers.



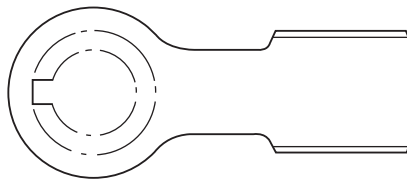
**Fig. 18.28** Typical locking plate for a hexagonal nut.



**(A)**



**(B)**



**(C)**

**Fig. 18.29** Locking terminals. (A) Flat type. (B) Bent type. (C) Flat-wing type.

these pins are assembled in accurate reamed holes. Undue force should not be used during the peening process or the security of the fittings may be impaired if the pin is bent.

Fig. 18.30A shows part of a lever which is fixed to a hollow operating shaft by a bifurcated taper pin. On assembly, a hole is drilled which is slightly smaller than the diameter at the small end of the taper pin and this is enlarged by a taper pin reamer so that the small end of the taper pin, when pushed through the assembly, is flush with the surface. The pin is then driven into position. If the pin is of the bifurcated type, then the legs are spread to form an included angle of about  $60^\circ$ . Fig. 18.30B shows the same operating lever assembled, but using a parallel pin, which has been peened over after ensuring that the component is adequately supported.

Fig. 18.31 shows the general shape of a taper pin. Parallel sides are substituted for tapered sides in parallel pins.

## Split cotter pins

Ferrous and non-ferrous split cotter pins are covered by BS 1574. The designating size of a split cotter pin is the size of the hole for which it is intended to fit. When reference is made to a split cotter pin in a parts list, this nominal dimension is followed by the length required. The closed legs of the shank of the pin form a circular cross-section.

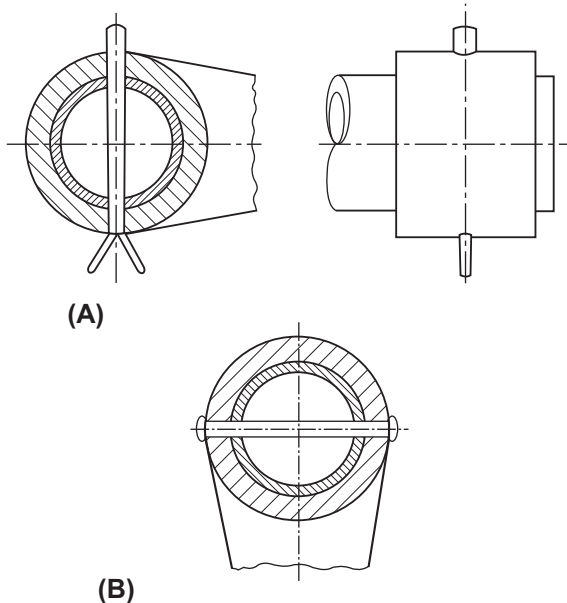
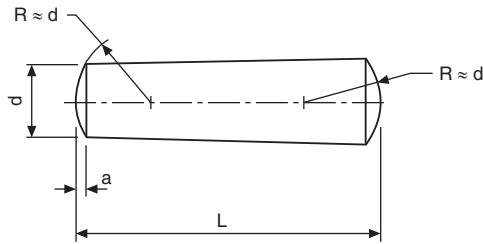
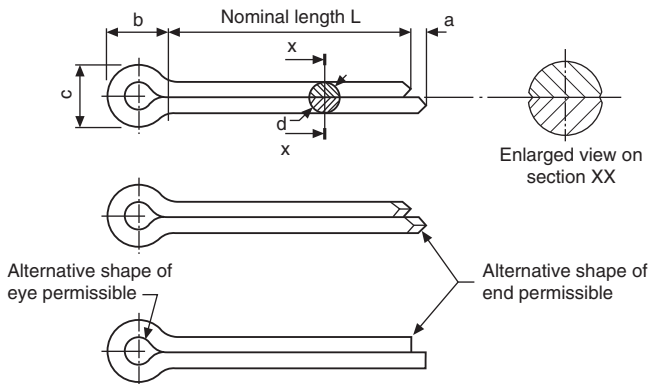


Fig. 18.30 Application of taper and parallel pins.



**Fig. 18.31** Taper pin details.



**Fig. 18.32** Proportions of split cotter pins to BS 1574.

The legs should be straight and parallel throughout their nominal length. [Fig. 18.32](#) shows alternative pins in detail ([Table 18.15](#)).

Exact dimensions are given in BS 1574 but for drawing purposes, the following extracts will be useful where the maximum allowable sizes for dimensions  $a$ ,  $b$ ,  $c$ , and  $d$  are quoted. Many standard lengths are obtainable for each pin size and as a rough guide between 5 and 25 times the shank diameter.

## Locking by adhesives

Small components found in, for example, instruments and switches may be locked by the application of Shellac, Araldite, Loctite, or similar materials. Shellac and Loctite are usually applied to the threads of nuts, bolts, screws and studs and the components are assembled while still wet. The parts should be free from grease to achieve maximum strength. Araldite is applied to the outside of the nut face and the protruding screw thread, after tightening. Araldite is an adhesive which hardens, after mixing, within a specified time period.

**Table 18.15** Split cotter pin dimensions.

Nominal diameter of pin (hole) diameter	Shank diameter $d$	Outside diameter of eye $C$	Length of eye $B$	Length extended prong $a$
1.0	0.9	1.8	3.0	1.6
1.2	1.0	2.0	3.0	2.5
1.6	1.4	2.8	3.2	2.5
2.0	1.8	3.6	4.0	2.5
2.5	2.3	4.6	5.0	2.5
3.2	2.9	5.8	6.4	3.2
4.0	3.7	7.4	8.0	4.0
5.0	4.6	9.2	10.0	4.0
6.3	5.9	11.8	12.6	4.0
8.0	7.5	15.0	16.0	4.0
10.0	9.5	19.0	20.0	6.3
13.0	12.4	24.8	26.0	6.3

## Peening

This operation prevents re-use of the screw or bolt but locking can be carried out by peening over about  $1\frac{1}{2}$  threads. This practice can be used in the case of screwed pivots and a simple example is often found in a pair of scissors. In the case of nuts and bolts, peening is carried down to the nut to prevent it from slackening.

Countersunk screws may be locked by peening metal from the surroundings into the screw slot. This practice is sometimes adopted when the thread is inaccessible.

## Thread-cutting screws

‘Shakeproof’ thread-cutting screws made from carbon steel are subjected to a special heat-treatment which provides a highly carburized surface with a toughened resilient core. The additional strength provided enables higher tightening torques to be used, and will often permit the use of a smaller size thread-cutting screw than would normally be specified for a machine screw. Thread-cutting screws actually cut their own mating thread; in any thickness of material a perfect thread-fit results in greatly increased holding power, extra vibration-resistance, and a faster assembly. The hard, keen cutting edge produces a clean-cut thread, from which the screw can be removed, if desired, without damage to screw or the cut thread. The most suitable

drill sizes for use with these screws are generally larger than standard tapping-drill sizes, but this apparent loss of thread engagement is more than offset by the perfect thread-fit obtained.

Both the screws shown in Fig. 18.33 are interchangeable with standard machine screws. Type 1 is recommended for use in steel and non-ferrous sheet and plate, and they are manufactured with a wide shank slot and are eminently suitable for paint-clearing applications, as they completely eliminate the need for expensive pre-production tapping of painted assemblies. Type 23 screws incorporate a special wide cutting slot with an acute cutting angle for fast, easy thread-cutting action and ample swarf clearance. These screws are specially designed for application into soft metals or plastics where a standard thread form is required.

The Type 25 thread-cutting screw has a specially spaced thread form which is designed for fast efficient fastening into plastics and sheet-metal applications (Fig. 18.34).

Fig. 18.35 illustrates a 'Tek's' self-drilling screw which, with a true drilling action, embodies three basic operations in one device. It (1) prepares its own hole, (2) either cuts or forms a mating thread, and (3) makes a complete fastening in a single operation. These screws consist of an actual drill point to which a threaded screw-fastener has been added. Several different head styles are available. During the drilling stage, Tek's must be supported rigidly from the head. Some bench-mounted, automatically fed screwdrivers provide a holding means which retracts as the screw is finally driven home. Other drivers connect with the fastener only through the bit or socket. A good-fitting Phillips or Posidriv bit will normally drive several thousands of these screws, and a hex socket, for hex-head designs, will drive even more.

For long screws or applications requiring absolutely guaranteed driving stability, a special chuck is available which holds the screw with three fingers and retracts upon contacting the work surface. These screws are suitable for fastening sheet steel of 16 gauge, or thicker, within 5 s maximum while using a power tool.

Fig. 18.36 shows alternative head styles available for thread-cutting screws.

The examples and dimensions of nuts, bolts, screws and washers given here are intended especially to be of use to students engaged on design projects. There are, however, literally hundreds of industrial fastening systems available, associated with

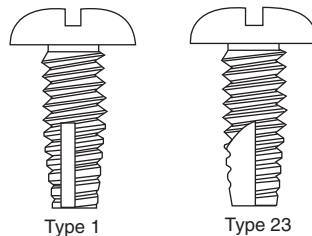
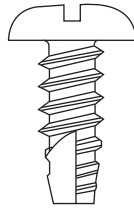
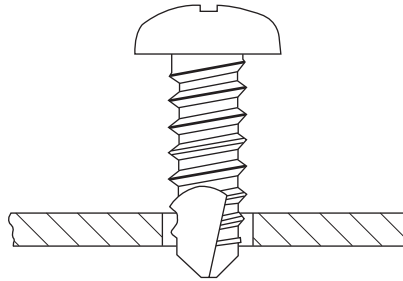


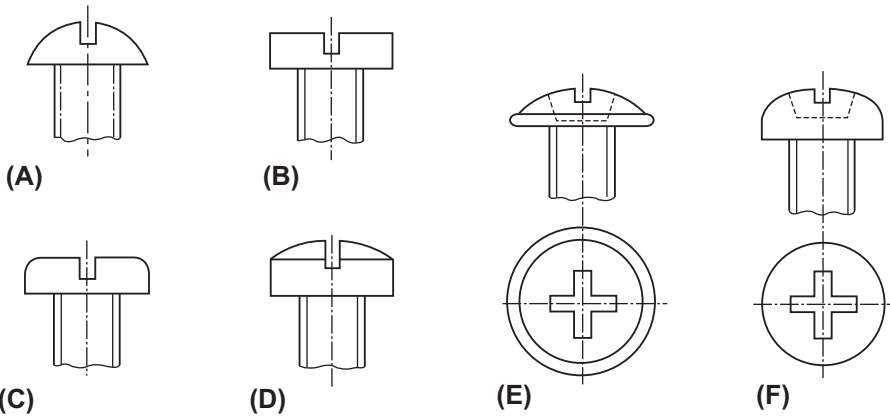
Fig. 18.33 Type 1 and 23 thread cutting screws.



**Fig. 18.34** Type 25 thread-cutting screw.



**Fig. 18.35** 'Teks' self-drilling screw.

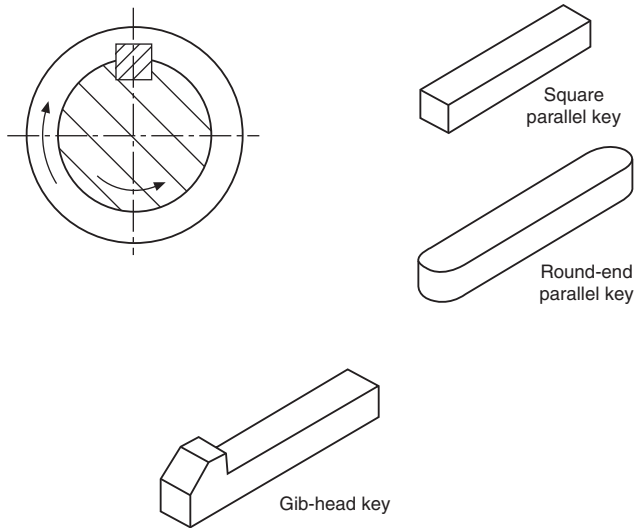


**Fig. 18.36** (A) Slotted round. (B) Slotted pan. (C) Slotted cheese. (D) Slotted fillister. (E) Pozidriv flange. (F) Pozidriv pan.

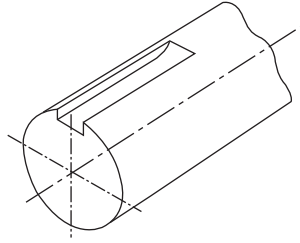
automobile, construction, electronics and aerospace developments. Manufacturers' catalogs are freely available to provide technical specifications and necessary details for designers. One further advantage of CAD systems is that such information can be used to build a library of useful data and drawings, which are invaluable, where contract drawings use a repetition of similar parts.

# Keys and key ways

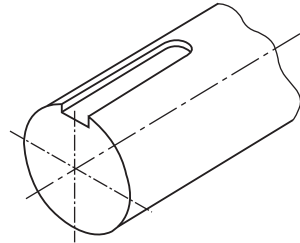
A key (Fig. 19.1), is usually made from steel and is inserted between the joint of two parts to prevent relative movement; it is also inserted between a shaft and a hub in an axial direction, to prevent relative rotation. A keyway (Figs. 19.2–19.4), is a recess in a shaft or hub to receive a key, and these recesses are commonly cut on key-seating machines or by broaching, milling, planning, shaping and slotting. The proportions of cross-sections of keys vary with the shaft size, and reference should be made to BS 4235 for the exact dimensions. The length of the key controls the area of the cross-section subject to shear, and will need to be calculated from the knowledge of the forces being transmitted or, in the case of feather keys, the additional information of the length of axial movement required.



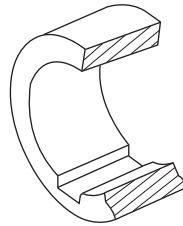
**Fig. 19.1** Examples and function of keys.



**Fig. 19.2** Edge-milled keyway.



**Fig. 19.3** End-milled keyway.



**Fig. 19.4** Keyway in hub.

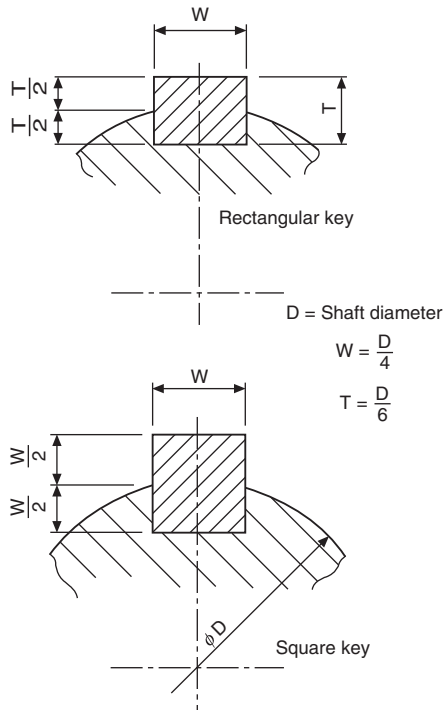
## Sunk keys

Examples of sunk keys are shown in [Fig. 19.5](#), where the key is sunk into the shaft for half its thickness. This measurement is taken at the side of the key, and not along the center line through the shaft axis. [Fig. 19.5](#) shows useful proportions used for assembly drawings.

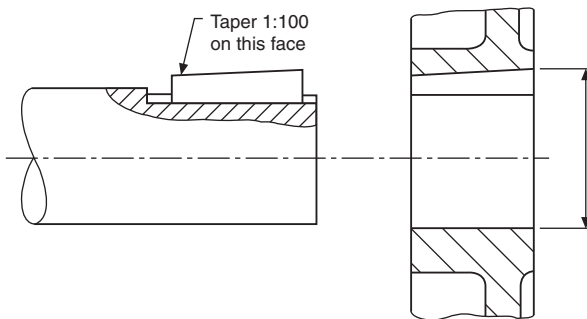
Square and rectangular keys may be made with a taper of 1 in 100 along the length of the key; [Fig. 19.6](#) shows such an application. Note that, when dimensioning the mating hub, the dimension into the keyway is taken across the maximum bore diameter.

A *gib head* may be added to a key to facilitate removal, and its proportions and position when assembled are given in [Fig. 19.7](#).

A *feather key* is attached to either the shaft or the hub, and permits relative axial movement while at the same time enabling a twisting moment to be transmitted



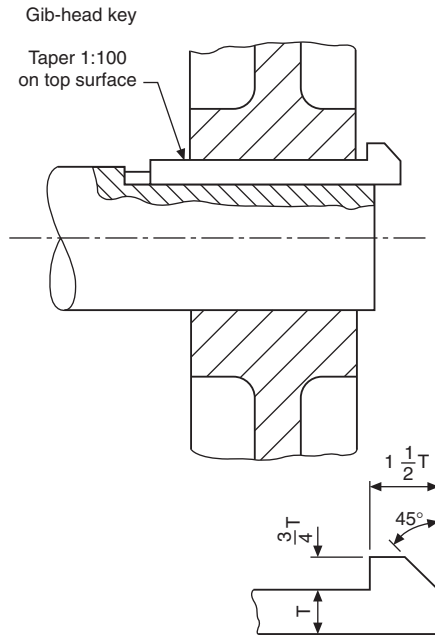
**Fig. 19.5** Sunk key and keyway.



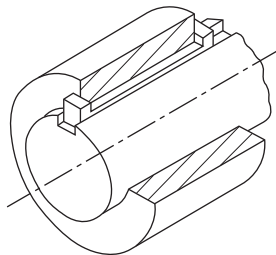
**Fig. 19.6** Taper key and keyway.

between shaft and hub or vice versa. Both pairs of opposite faces of the key are parallel.

A *double-headed feather key* is shown in Fig. 19.8 and allows a relatively large degree of sliding motion between shaft and hub. The key is inserted into the bore of the hub, and the assembly is then fed on to the shaft, thus locking the key in position.



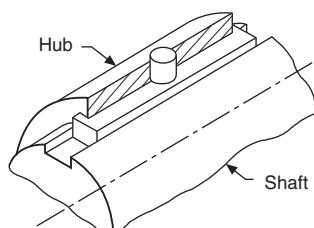
**Fig. 19.7** Gib-head key.



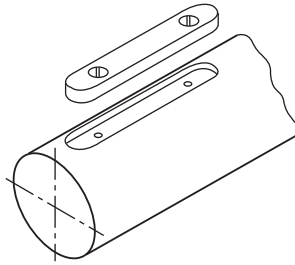
**Fig. 19.8** Double-headed feather key.

A *peg feather key* is shown in [Fig. 19.9](#), where a peg attached to the key is located in a hole through the hub.

[Fig. 19.10](#) illustrates a feather key which is screwed in position in the shaft keyway by two countersunk screws.



**Fig. 19.9** Peg feather key.



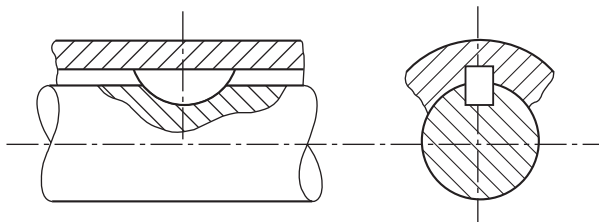
**Fig. 19.10** Feather key.

## Woodruff keys

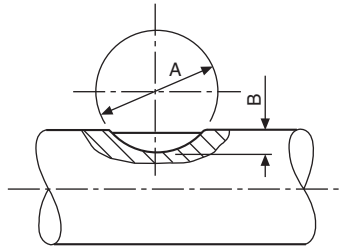
A Woodruff key (Fig. 19.11), is a segment of a circular disc and fits into a circular recess in the shaft which is machined by a Woodruff key way cutter. The shaft may be parallel or tapered (Fig. 19.12 and 19.13) showing the method of dimensioning shafts for Woodruff keys where the depth of the recess from the outside of the shaft is given, in addition to the diameter of the recess. A Woodruff key has the advantage that it will turn itself in its circular recess to accommodate any taper in the mating hub on assembly; for this reason it cannot be used as a feather key, since it would jam. Woodruff keys are commonly used in machine tools and, for example, between the flywheel and the crankshaft of a small internal-combustion engine where the drive depends largely on the fit between the shaft and the conically bored flywheel hub. The deep recess for a Woodruff key weakens the shaft, but there is little tendency for the key to turn over when in use.

Where lighter loads are transmitted and the cost of cutting a keyway is not justified, round keys and flat or hollow saddle keys as shown in Fig. 19.14 can be used.

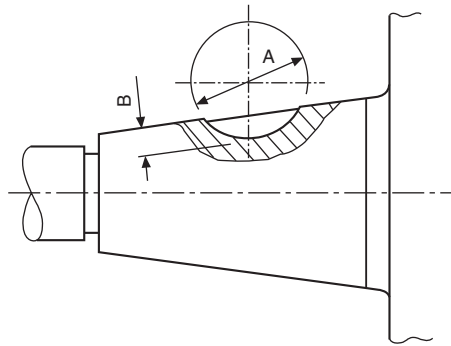
Saddle keys are essentially for light duty only, overloading tending to make them rock and work loose on the shaft. Both flat and hollow saddle keys may have a taper of 1 in 100 on the face in contact with the hub. The round key may either be tapered or, on assembly, the end of the shaft and hub may be tapped after drilling and a special threaded key be screwed in to secure the components.



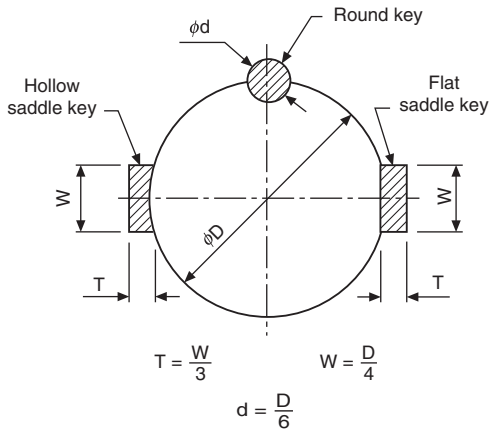
**Fig. 19.11** Woodruff key.



**Fig. 19.12** Dimensions required for a Woodruff key in a parallel shaft.



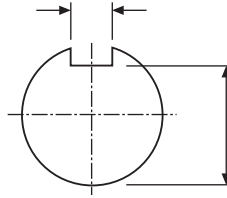
**Fig. 19.13** Dimensions required for a Woodruff key in a tapered shaft.



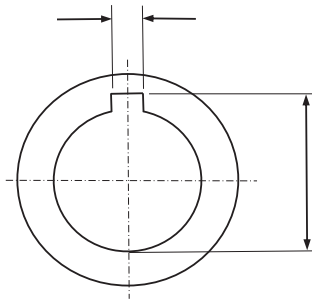
**Fig. 19.14** Application of round, flat and hollow saddle keys.

## Dimensioning keyways (parallel keys)

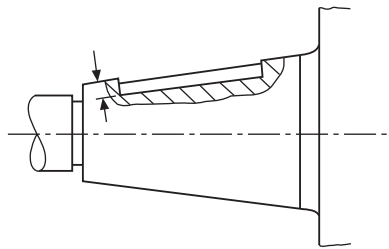
The method of dimensioning a parallel shaft is shown in [Fig. 19.15](#), and a parallel hub in [Fig. 19.16](#). Note that in each case it is essential to show the dimension to the bottom of the keyway measured across the diameter of the shaft and the bore of the hub.



**Fig. 19.15** Keyway in parallel shaft.

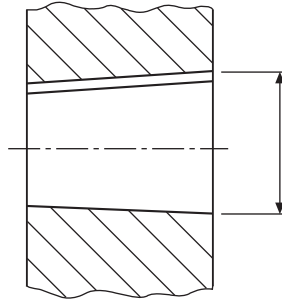


**Fig. 19.16** Keyway in parallel hub.

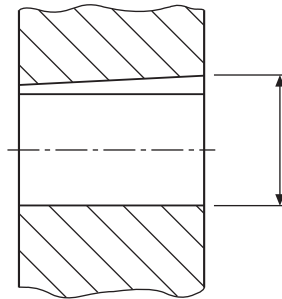


**Fig. 19.17** Keyway for square or rectangular parallel key in tapered shaft.

This practice cannot be used where either the shaft or hub is tapered, and [Fig. 19.17](#) shows the method of dimensioning a keyway for a square or rectangular parallel key in a tapered shaft, where the keyway depth is shown from the outside edge of the shaft and is measured vertically into the bottom of the slot. [Fig. 19.18](#) shows a



**Fig. 19.18** Tapered hub with parallel keyway.



**Fig. 19.19** Parallel hub with tapered keyway.

tapered hub with a parallel keyway where the dimension to the bottom of the slot is taken across the major diameter. A parallel hub utilizing a tapered key is also dimensioned across the major diameter, as indicated in [Fig. 19.19](#).

# Worked examples in machine drawing

# 20

Examination questions generally relate to single parts or assemblies of detailed components, and test the student's ability to draw sectional and outside views. British Standards refer to 'views' but other terms have been traditionally used in technical drawing. The front or side view of a house is quite likely to be known as an *elevation*, and a 'bird's eye view' as a *plan*. These expressions are freely used.

The examples which follow are of examination standard and a student designer would be expected to produce a reasonably complete solution for each problem in about 2–3 h.

Before commencing, try to estimate the areas covered by the views so that they can be presented with reasonably equal spaces horizontally and vertically on the drawing sheet. Include a border about 15 mm width, and add a title block and parts list if necessary. Note that attention to small details will gradually enable you to improve the quality of your draughting.

In an industrial situation, before commencing a drawing, the designer will make a mental picture of how to orient the component, or arrangement, so that the maximum amount of information can be indicated with the minimum number of views necessary to produce a clear, unambiguous solution. However, this is easier said than done in the case of the student, and especially where the drawing is being made on CAD (computer aided design) equipment since the size of the screen often means that part of the drawing is temporarily out of sight. This is part of the learning experience.

Copy the following solutions and try to appreciate the reasons for the position of every line which contributes to the finished drawing.

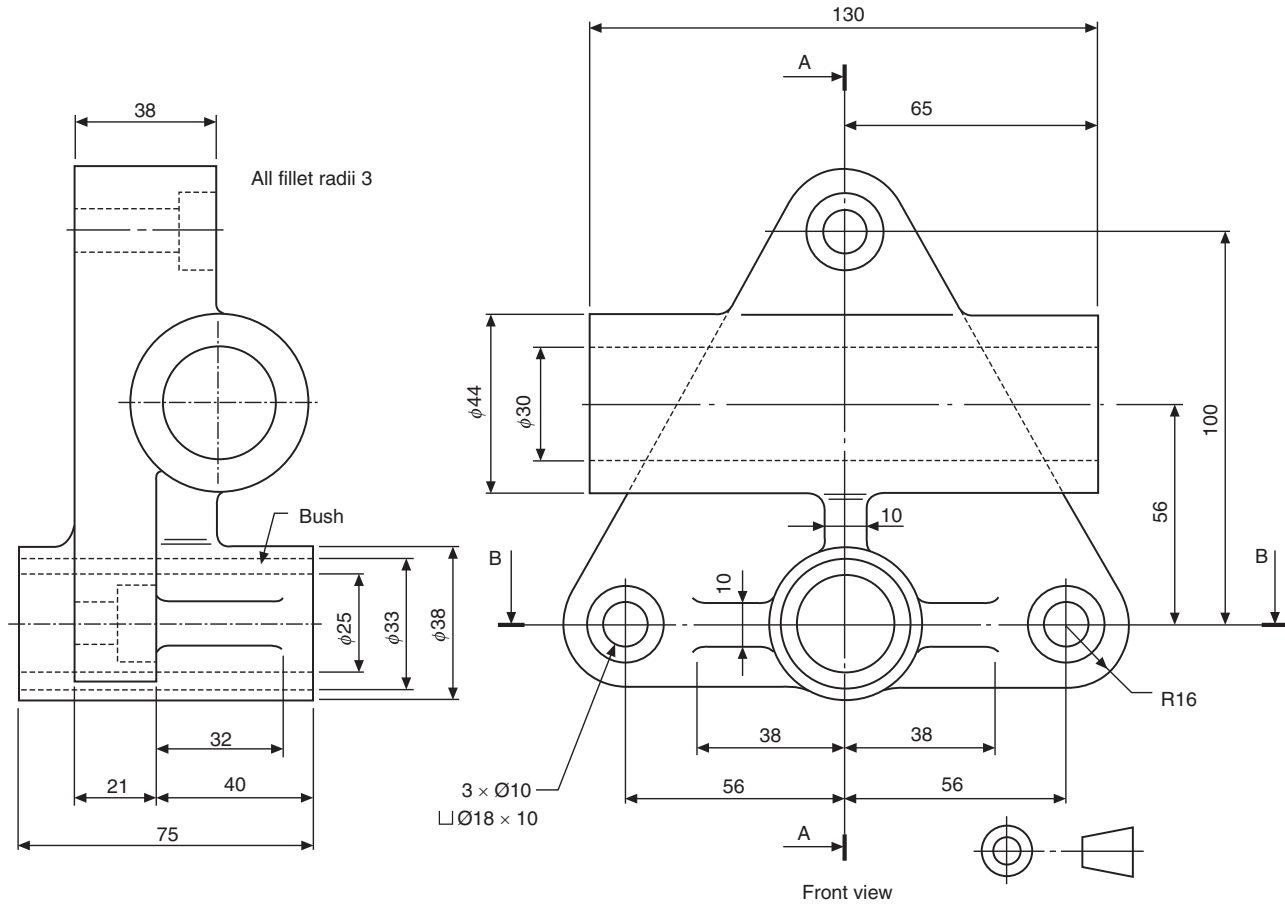
## Bushed bearing bracket

Front- and end-views of a bushed bearing bracket are shown in Fig. 20.1. Copy the given front view and project from it a sectional-end view and a sectional-plan view taken from cutting planes A–A and B–B. Draw your solution in first angle projection. Note that the question is presented in third angle projection.

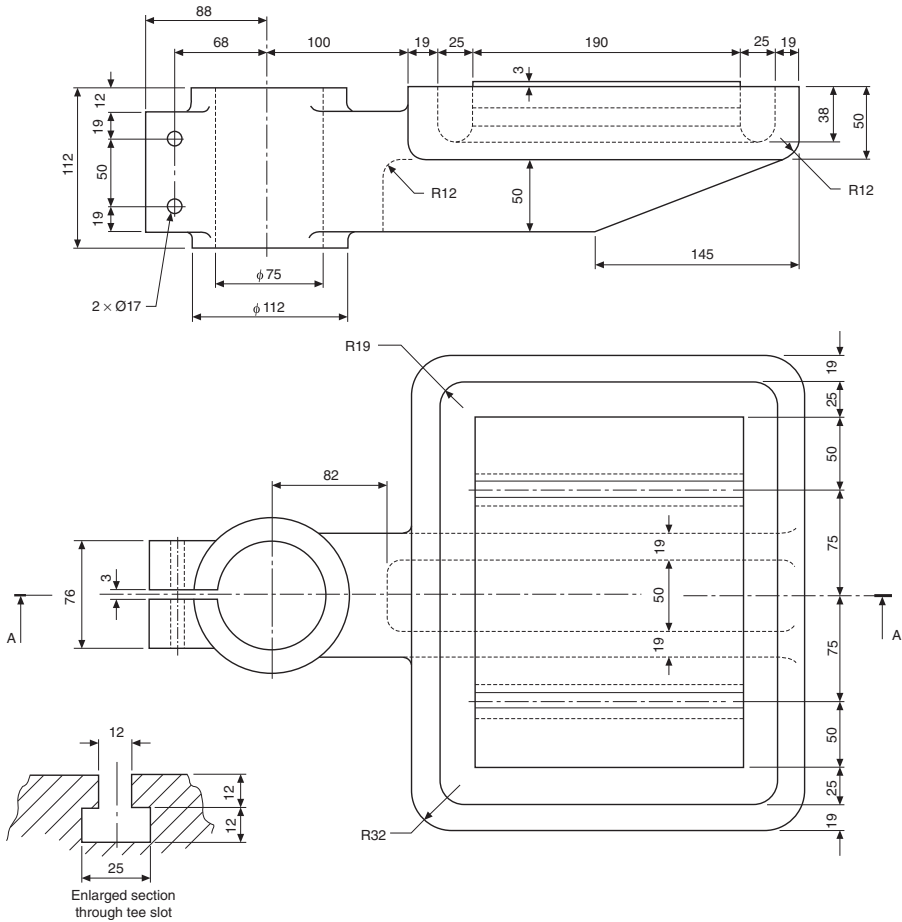
## Drill table

Fig. 20.2 shows details of a table for a drilling machine. Draw half-full-size the following views:

- (a) A front view taken as a section along the cutting plane A–A.
- (b) The given plan view with hidden detail.
- (c) An end view projected to the left of the front view with hidden detail included.



**Fig. 20.1** Bushed bearing bracket.



**Fig. 20.2** Drill Table Note: All unspecified radii 6mm.

Draw your solution in first angle projection and add the title and projection symbol in a suitable title block.

## Cam operated clamp

Details of a cam operated clamp are shown in Fig. 20.3 together with a key showing the position of the various components in the assembly. Draw the following views in first angle projection:

- (a) A front view taken as a section through the vertical center line of the clamp and generally as outlined in the key.

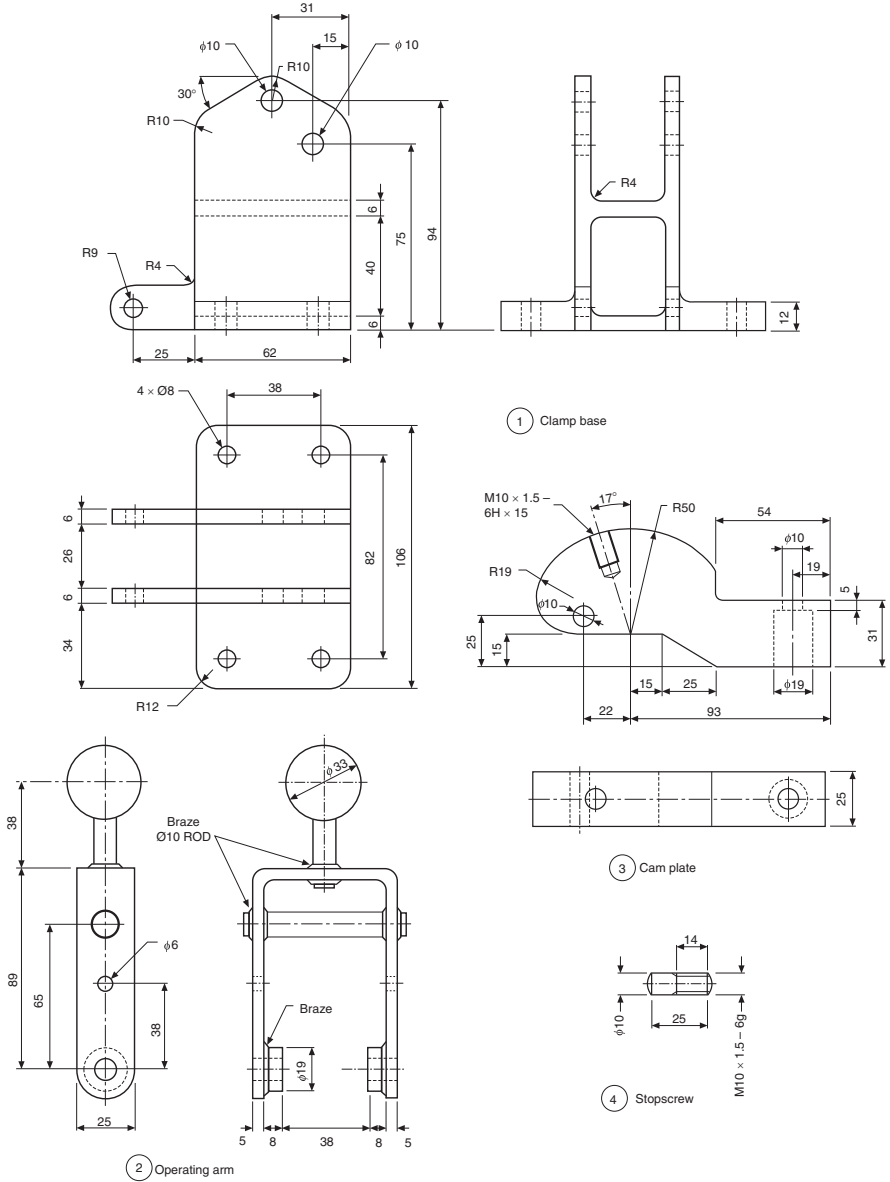
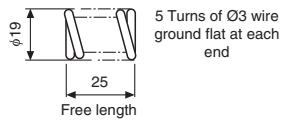
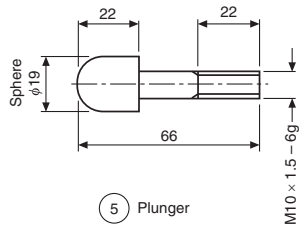
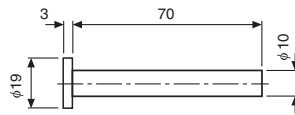


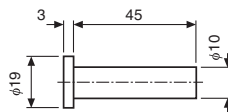
Fig. 20.3 Cam operated clamp details.



6 Spring



7 Arm pivot



8 Cam pivot

Note: On assembly, fit a suitable washer over each pivot and drill for 2 mm  $\text{O}$  split pin

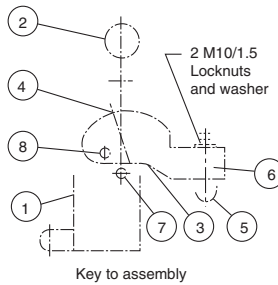


Fig. 20.3 Cont'd.

- (b) An end view projected on the right-hand side of the front view.
- (c) A plan view drawn beneath the front view.

Add to your solution a title, scale, projection symbol, parts list and reference balloons.

## Plug cock

Details of a plug cock are shown in [Fig. 20.4](#). Draw the following two views of the assembled plug cock:

- (a) A view in half section showing the outside view on the left of the vertical center line and a section on the right-hand side, the position of the valve body being similar to that shown on the given detail.
- (b) An outside-end view.

Add a title and a parts list. Hidden details are not required in either view. Include on your assembly suitable nuts and bolts and washers where applicable. Between the valve body and cover include a joint ring of thickness 2 mm. The gland should be positioned entering 10 mm into the valve cover. First or third angle projected views will be acceptable.

## Air engine

The component parts of an oscillating air engine are detailed in [Fig. 20.5](#). Draw in first angle projection and, at twice full size, the following views:

- (a) A front view taken as a section through the engine cylinder and flywheel.
- (b) A plan view in projection with the front view and drawn below the front view.
- (c) An end view on the right-hand side and in projection with the front view.

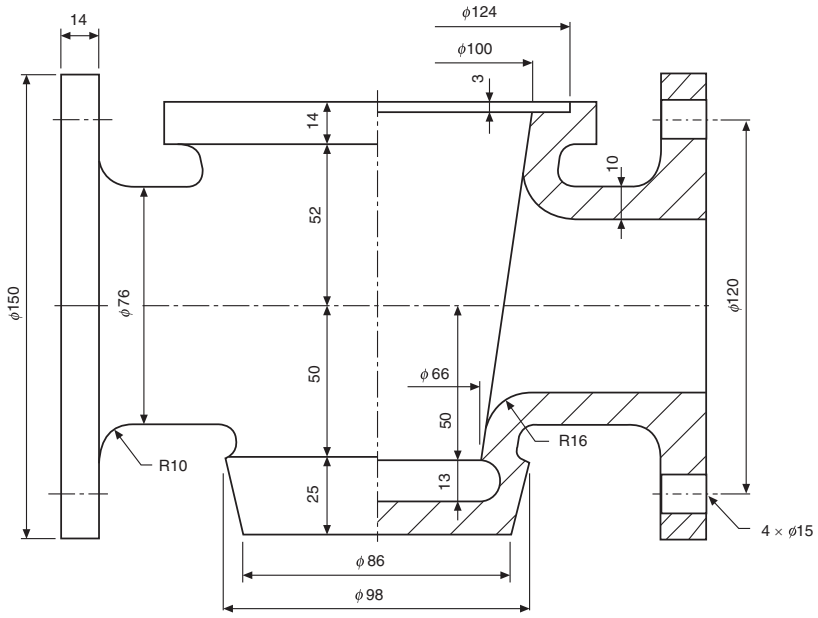
Hidden detail is not required in any view. Add a parts list to your drawing and reference balloons to identify each of the components in the assembly.

## Toolbox

The details in [Fig. 20.6](#) show parts of a toolbox that can be made as a sheet-metalwork exercise.

A development is given of the end plates (two required) and these should be drilled at the corners before bending, to avoid possible cracking taking place. Note, from the photograph, that the ends have been pressed with grooves to provide additional stiffening and this can be done if facilities are available.

The bottom and sides are fabricated in one piece and drillings are shown for pop rivets. Drill the end plates using the sides as templates to take account of deformation which may occur while bending the metal plate.



1 Valve body

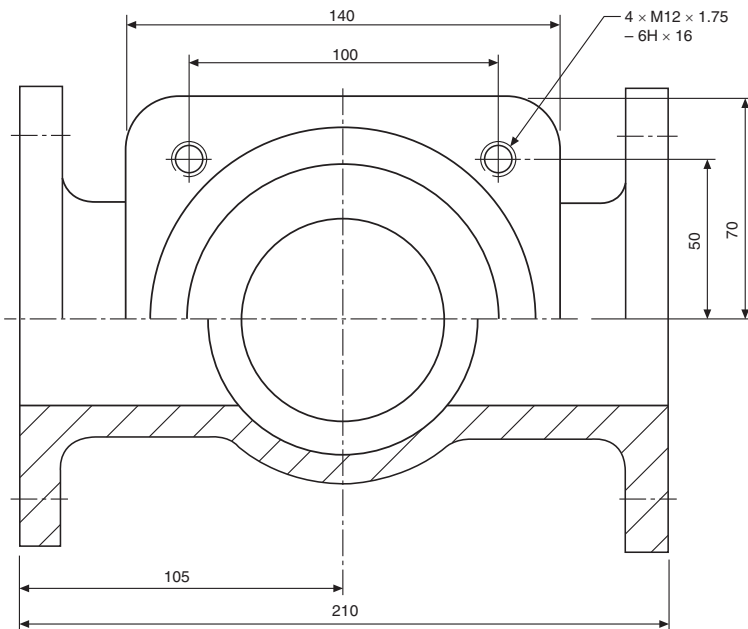


Fig. 20.4 Plug cock details.

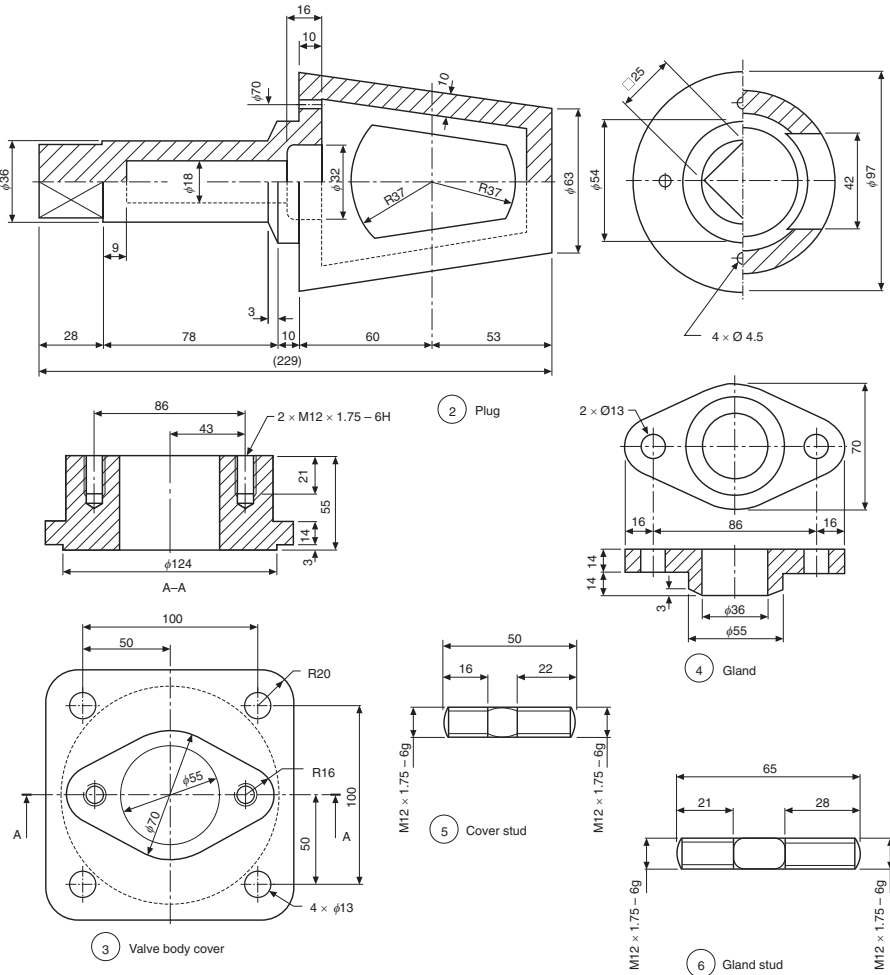
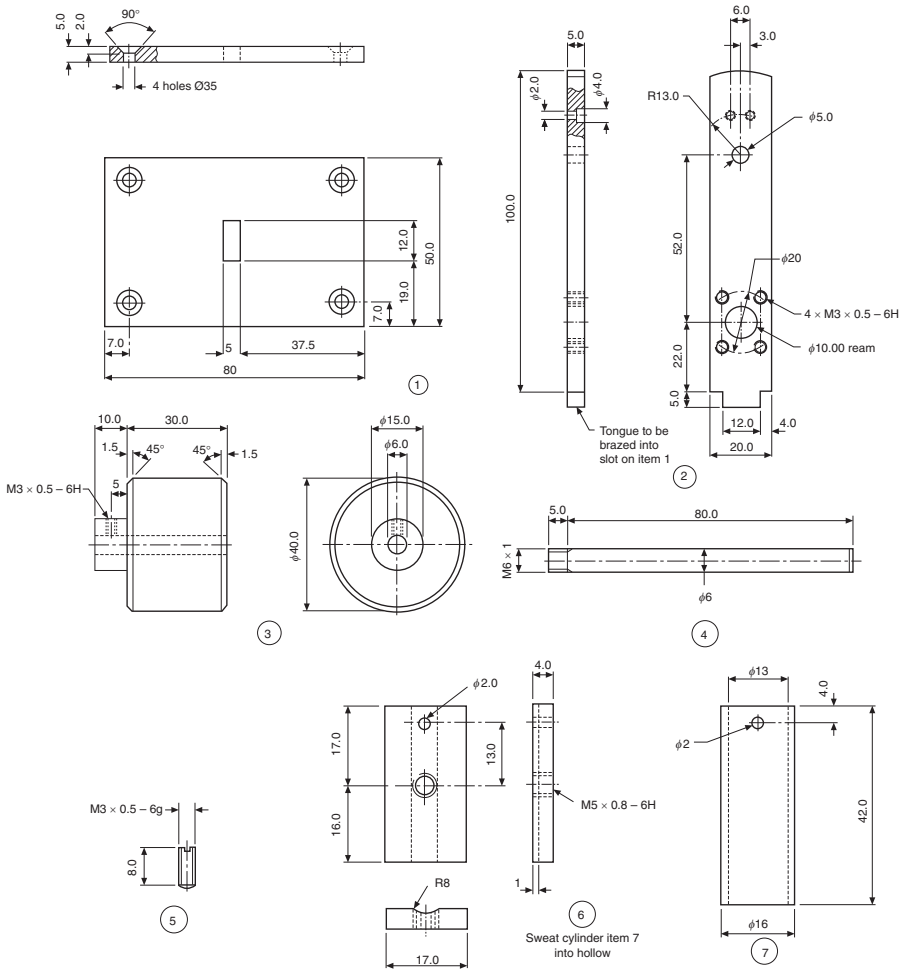


Fig. 20.4 Cont'd.

Details are shown of the hinges and some clearance must be provided for their satisfactory operation. Before drilling the sides and lids for the hinges using the dimensions given, use the hinges as manufactured to check the hole centers for the rivets. One lid must overlap the other to close the box, so some adjustment here may be required. On the toolbox illustrated, pop rivets were used on the sides and roundhead rivets on the lid. Roundhead rivets were also used to assemble the handle clips. Check also that the drill sizes for the rivets used as alternatives are available.

The top support member was pop riveted to the end plates after the catch had been welded on the underside. The slot in each lid slips over this catch to allow a padlock to secure the toolbox.



**Fig. 20.5** Air engine details.

A tooltray may also be made if required and details are provided. The tray supports also offer added stability and were pop riveted on assembly.

Remove all sharp corners and edges before assembly of each part. The completed toolbox can be stove enamelled, painted or sprayed according to personal choice.

As an additional exercise, copy the given details and produce an assembly drawing complete with parts list. Also, produce patterns to cut the components from sheet metal economically. This example provides useful practice in reading and applying engineering drawings.

The solution is shown in Fig. 20.12 (and see Fig. 20.13).

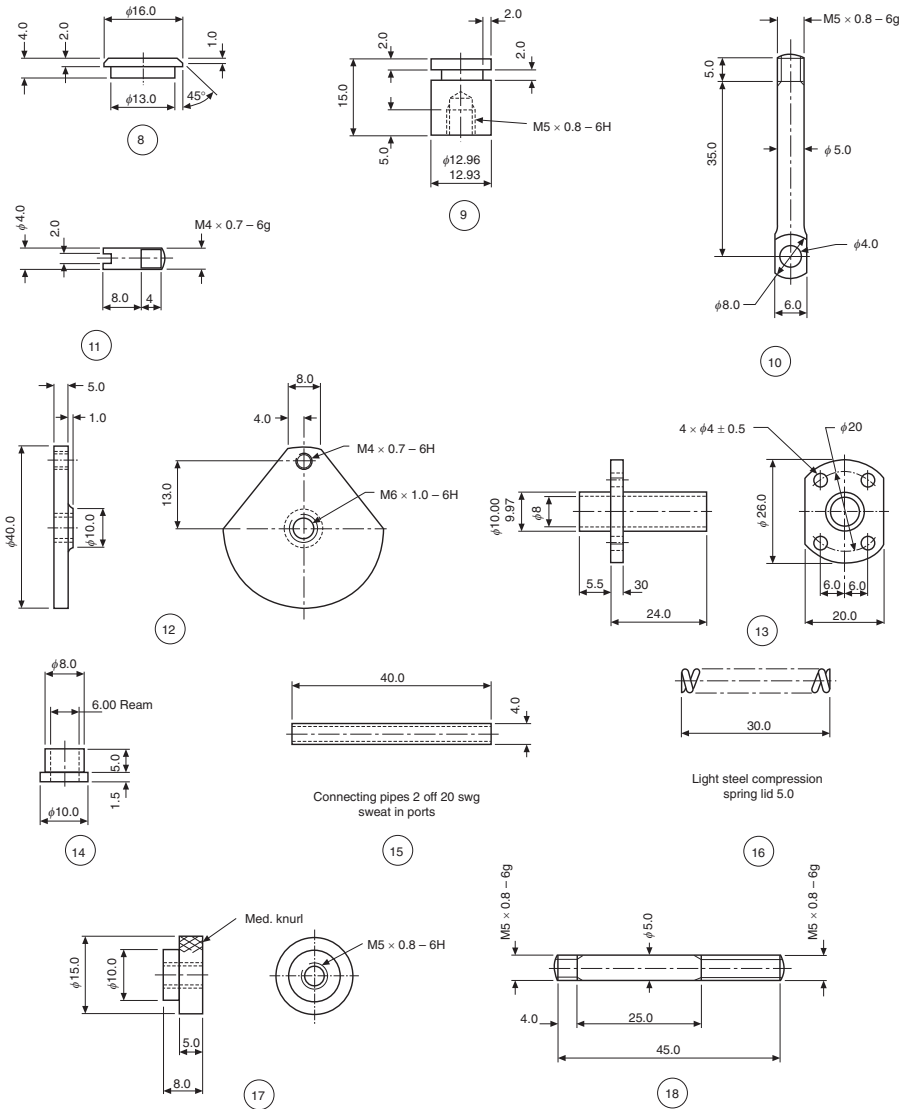
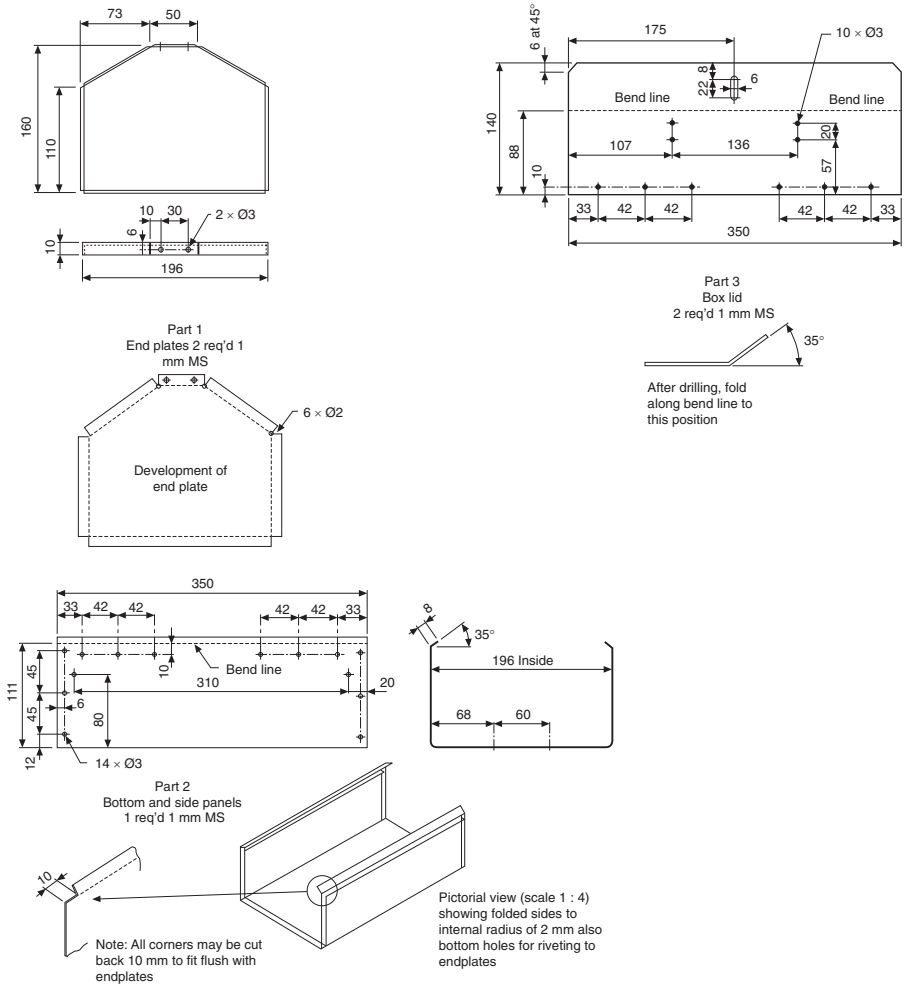


Fig. 20.5 Cont'd.

## Solution notes

### Bushed bearing bracket (Fig. 20.7)

Note that in the end view there is an example of a thin web which is not cross-hatched. The example shows three examples of counterbored holes used to contain heads of fixing screws.



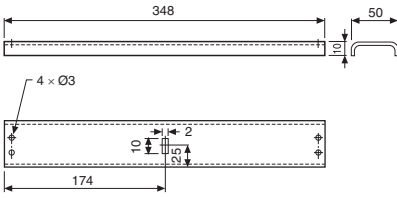
**Fig. 20.6** Tool box details.

A liner bush with an interference fit is also indicated, and since the bush is relatively thin compared with the main casting, its cross-hatching lines are drawn closer together.

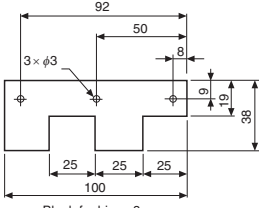
**Drill table (Fig. 20.8)**

The table is clamped to the drilling machine main vertical pillar using two bolts. An individual slot permits tightening.

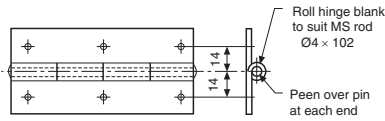
Cross-hatching is omitted on its left side of the front view.



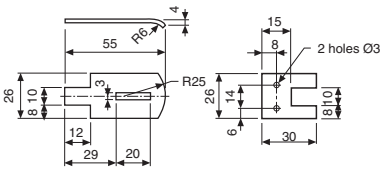
Part 4  
Top support  
1 req'd 1 mm MS  
Assemble under end plates  
by pop riveting



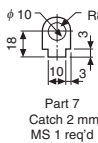
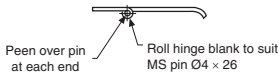
Blank for hinge 8  
req'd



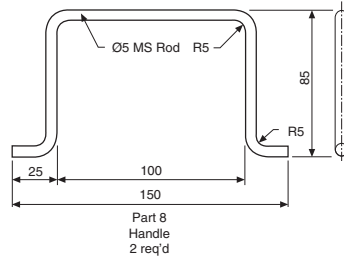
Part 5  
Assembled hinge  
4 req'd 1 mm MS



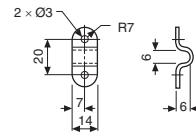
Part 6  
Hasp  
1 req'd 1 mm MS



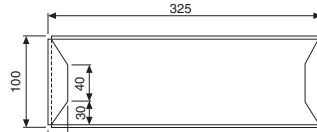
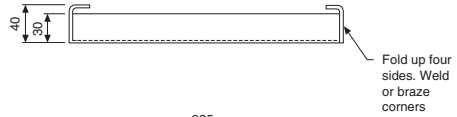
Part 7  
Catch 2 mm  
MS 1 req'd



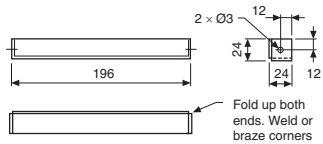
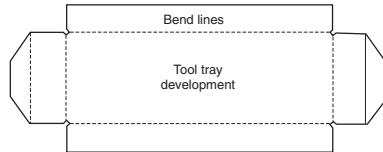
Part 8  
Handle  
2 req'd



Part 9  
Handle clips  
4 req'd 1 mm MS



Part 10  
Tooltray  
1 req'd 1 mm MS



Part 11  
Tray support bracket  
2 req'd 1 mm MS

Fig. 20.6 Cont'd.

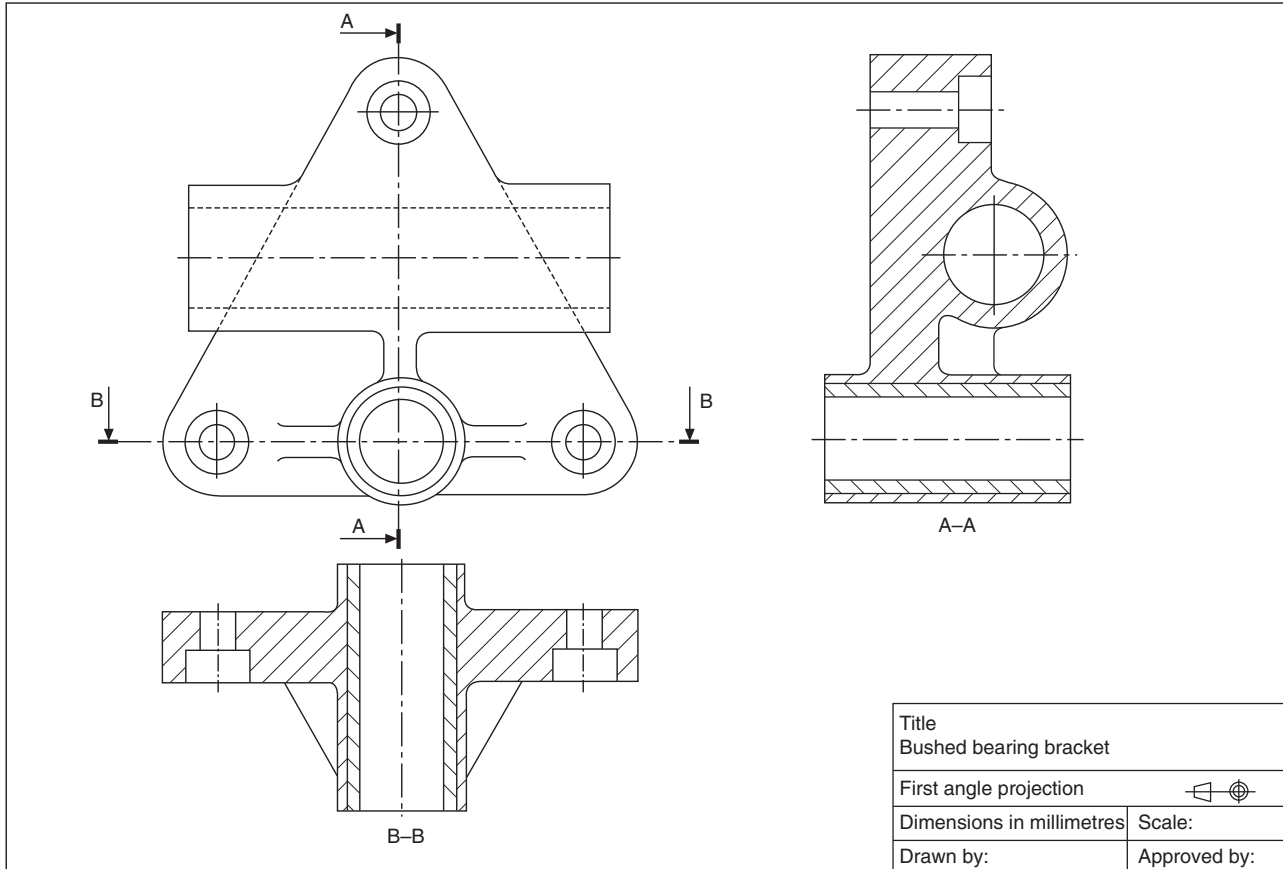


Fig. 20.7 Bushed bearing solution.

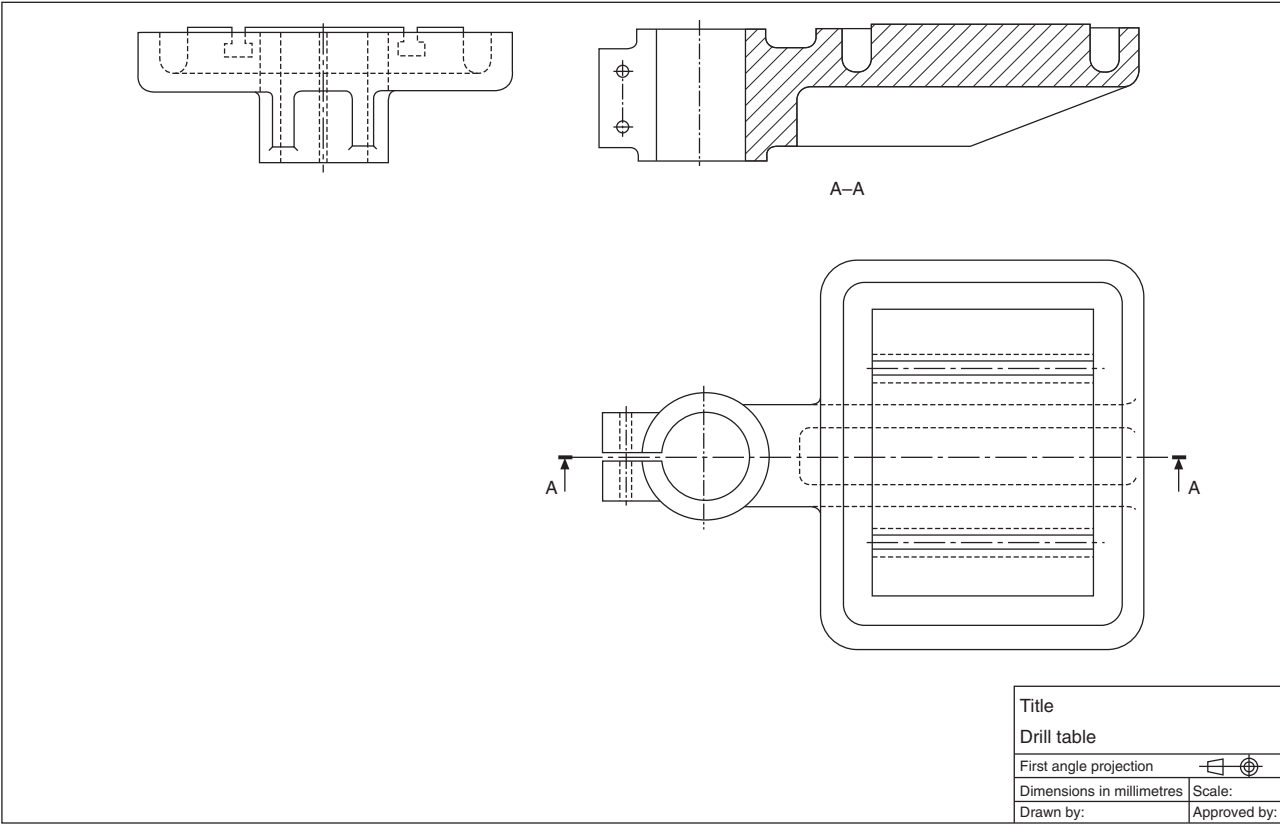
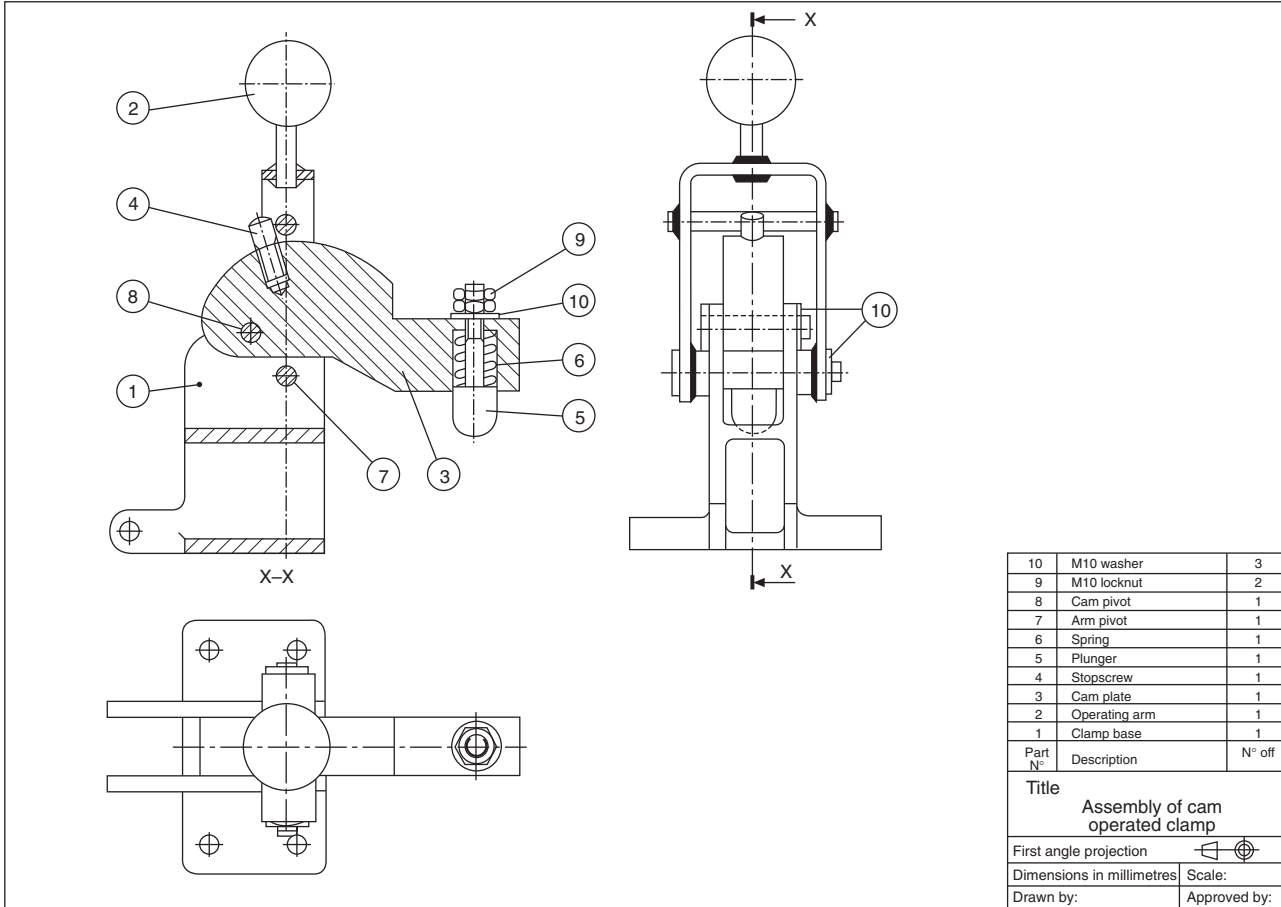


Fig. 20.8 Drill table solution.



**Fig. 20.9** Cam operated clamp solution.

### **Cam operated clamp (Fig. 20.9)**

This example shows a typical assembly and includes a parts list.

The balloons containing the part numbers are equally spaced whenever possible. The leader lines to the components terminate in a dot. An individual leader line is also directed toward the center of its balloon and touches the circumference.

It is considered good policy to position the parts list and commence writing in such a way that parts can be added on to the end of the list in the event of future modifications. The list can be drawn at the top or bottom of the drawing sheet.

### **Plug cock assembly (Fig. 20.10)**

This example illustrates a typical industrial valve. The plug turns through  $90^\circ$  between the on and off positions. Spanner flats are provided and indicated by the diagonal lines. Gland packing (Part 10) is supplied in rings. These rings are contained by the body cover and on assembly are fed over the plug spindle. The gland is tightened and the compressive force squeezes the packing to provide a seal, sufficient to prevent leaks, but enabling the spindle to be turned. The joint ring (Part 9) is too thin to be cross-hatched and is shown filled in.

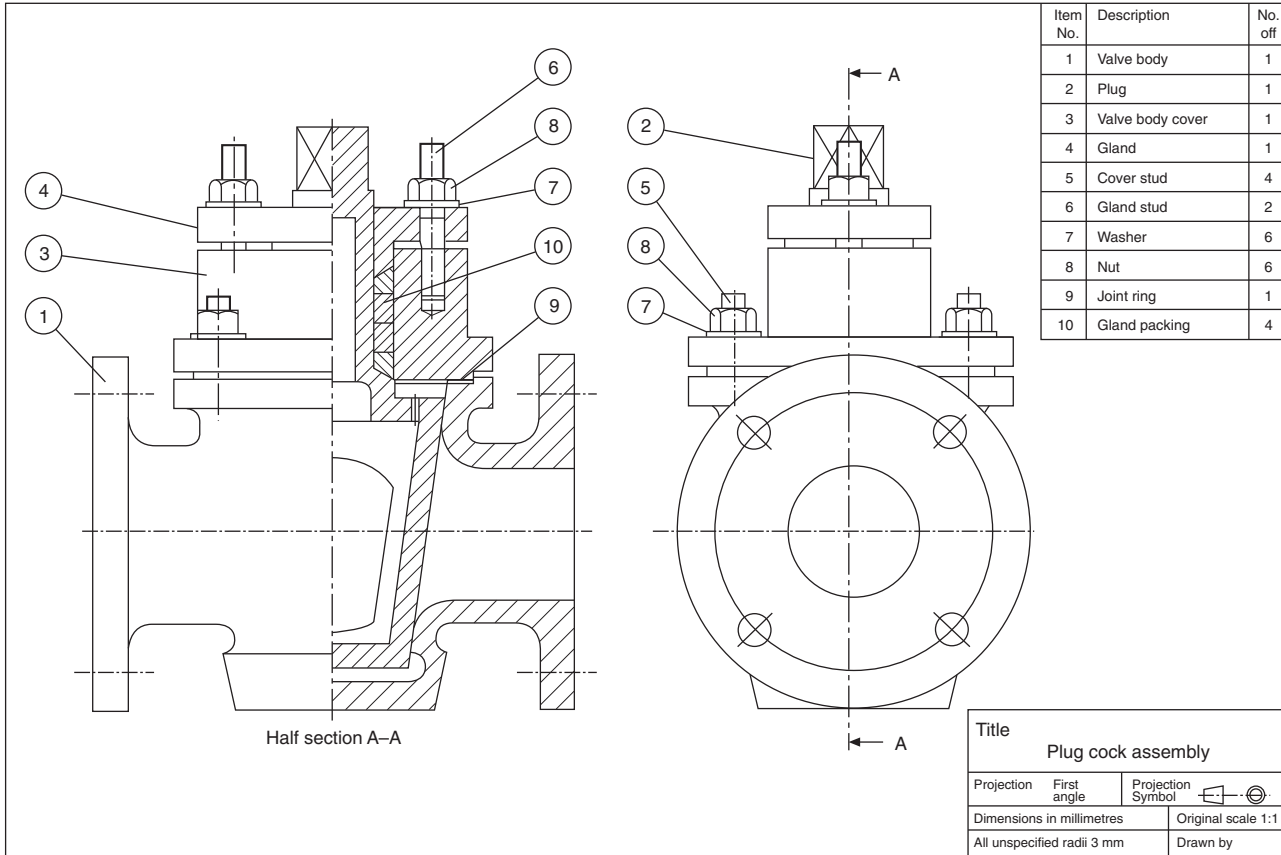
This is also an example of a symmetrical part where the half section gives an outside view and a sectional view to indicate the internal details.

### **Air engine assembly (Fig. 20.11)**

The engine operates through compressed air entering the cylinder via one of the connecting pipes shown as item 15. The other pipe serves to exhaust the cylinder after the power stroke. The cylinder oscillates in an arc and a hole through the cylinder wall lines up with the inlet and exhaust pipes at each  $180^\circ$  of rotation of the flywheel.

The spindles (Parts 4 and 18), grub screw (Part 5) and the pin (Part 11) would not normally be sectioned. A part section is illustrated at the bottom of the connecting rod in order to show its assembly with the crank pin (Part 11). The BS convention is shown for the spring (Part 16). The BS convention is also shown for cross knurling on the nut (Part 17) (Fig. 20.12).

*Note:* If the solutions to examples 3, 4, 5, and 6 had been required to be drawn in third angle projection, then the views would have been arranged as shown in Fig. 20.13.



**Fig. 20.10** Plug cock assembly solution.

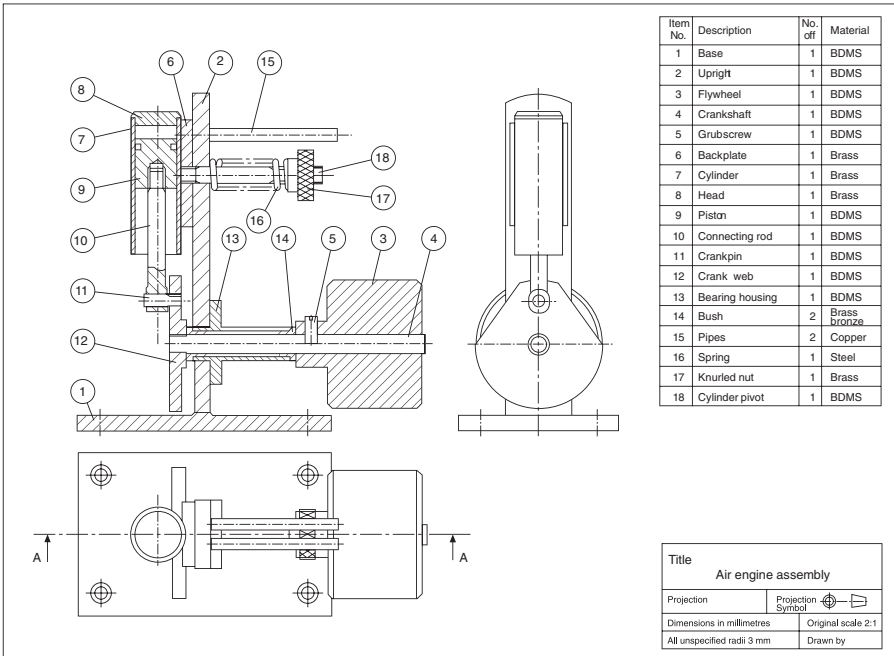
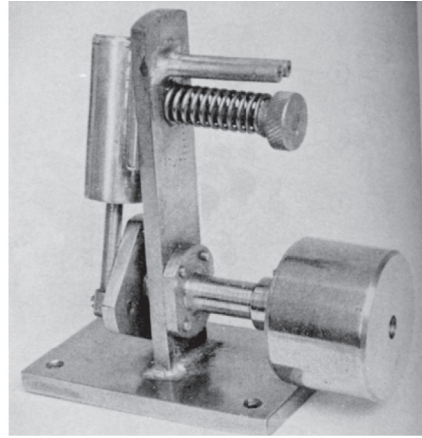
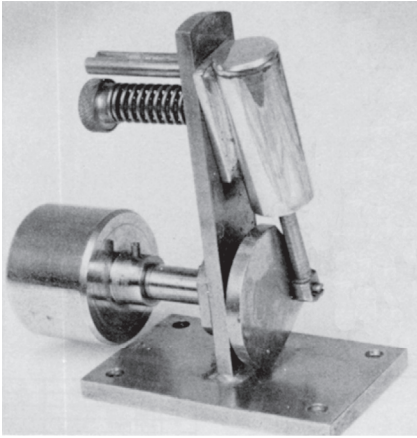


Fig. 20.11 Air engine solution.

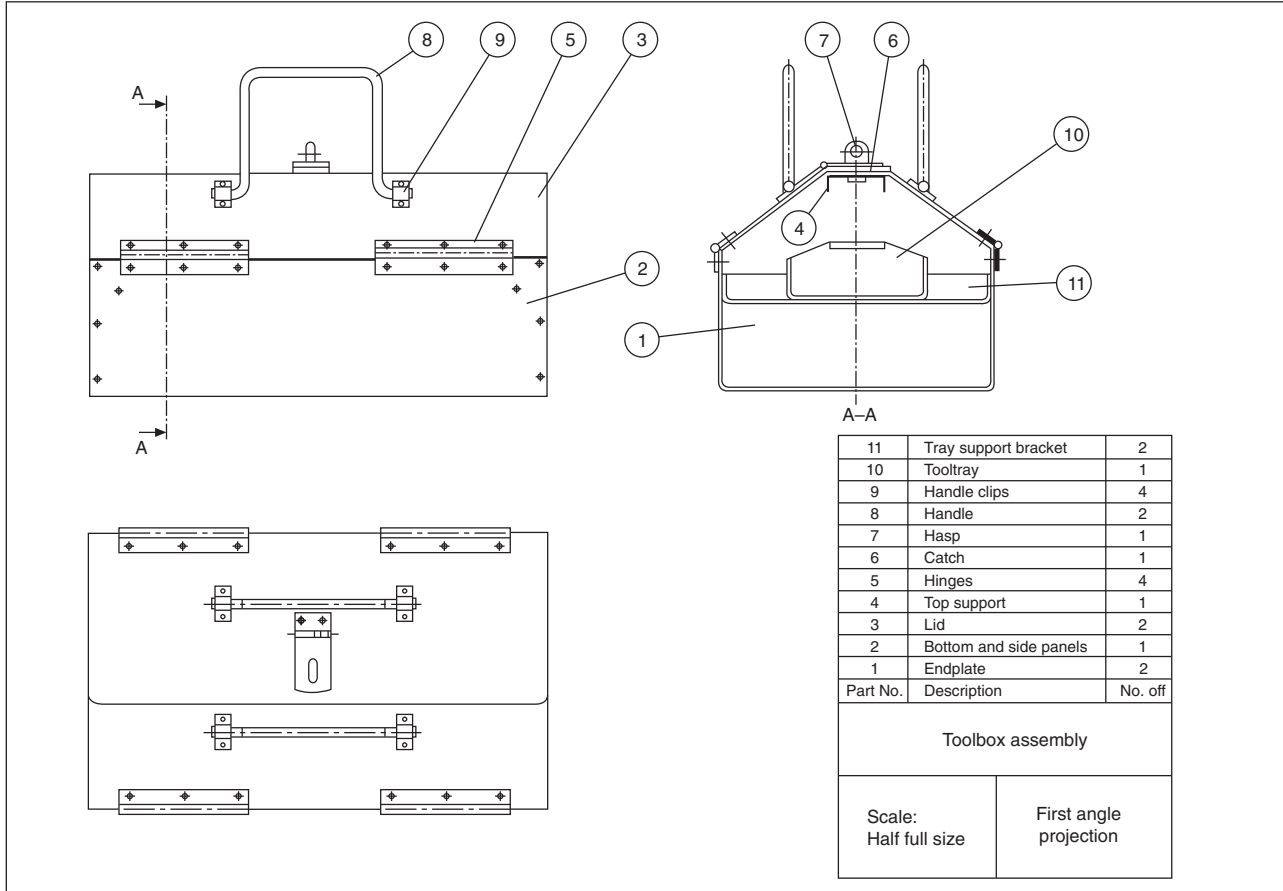


Fig. 20.12 Toolbox solution.

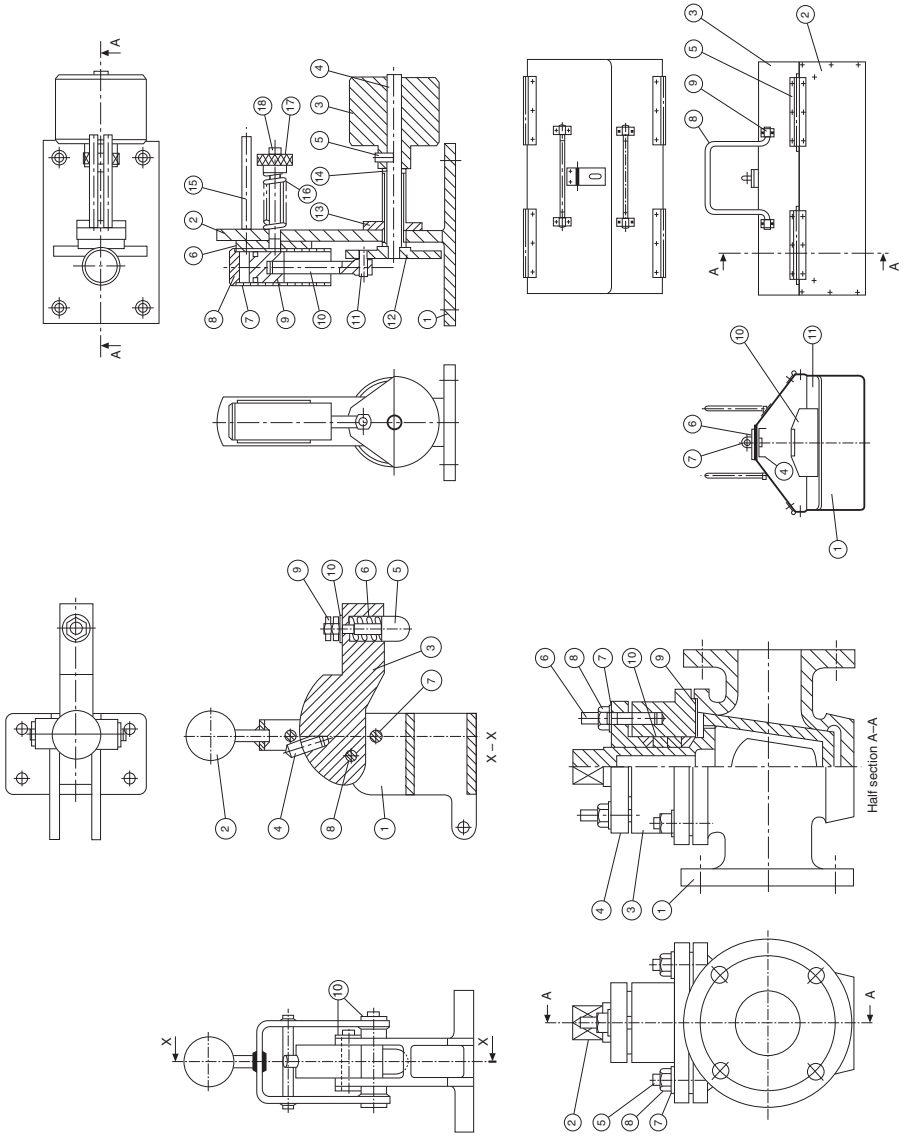


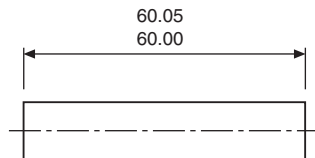
Fig. 20.13 Solutions in third angle peoction.

To ensure that an assembly will function correctly, its component parts must fit together in a predictable manner. Now, in practice, no component can be manufactured to an exact size, and one of the problems facing the designer is to decide the upper and lower limits of size which are acceptable for each of the dimensions used to define shape and form and which will ensure satisfactory operation in service. For example, a dimension of  $10 \pm 0.02$  means that a part will be acceptable if manufactured anywhere between the limits of size of 9.98 and 10.02 mm. The present system of manufacture of interchangeable parts was brought about by the advent of and the needs of mass production, and has the following advantages.

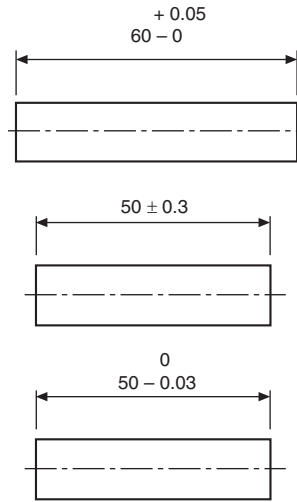
1. Instead of 'fitting' components together, which requires some adjustment of size and a high degree of skill, they can be 'assembled'.
2. An assembly can be serviced by replacing defective parts with components manufactured to within the same range of dimensions.
3. Parts can be produced in large quantities, in some cases with less demand on the skill of the operator. Invariably this requires the use of special-purpose machines, tools, jigs, fixtures, and gauges: but the final cost of each component will be far less than if made separately by a skilled craftsman.

It should be noted, however, that full interchangeability is not always necessary in practice; neither is it always feasible, especially when the dimensions are required to be controlled very closely in size. Many units used in the construction of motor vehicles are assembled after an elaborate inspection process has sorted the components into different groups according to size. Suppose, for example, that it was required to maintain the clearance between a piston and a cylinder to within 0.012 mm. To maintain full interchangeability would require both the piston and the cylinder bores to be finished to a tolerance of 0.006 mm, which would be difficult to maintain and also uneconomical to produce. In practice it is possible to manufacture both bores and pistons to within a tolerance of 0.06 mm and then divide them into groups for assembly; this involves the gauging of each component.

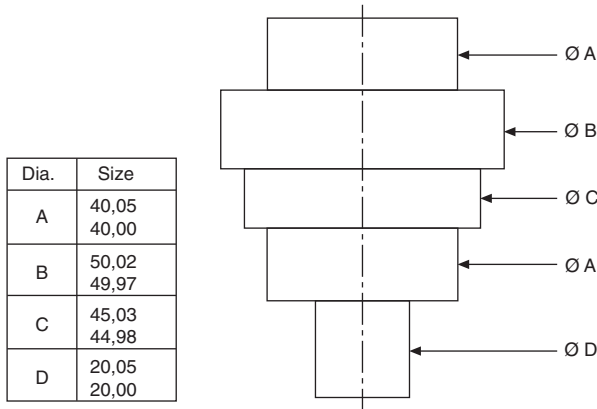
A designer should ensure that the drawing conveys clear instructions regarding the upper and lower limits of size for each dimension, and Figs. 21.1–21.4 show typical methods in common use. The method in figure 21.1 is recommended for all engineering drawings.



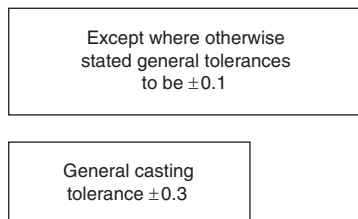
**Fig. 21.1** Upper and lower limits of tolerance fully defined.



**Fig. 21.2** Examples of plus/minus tolerances.



**Fig. 21.3** Tabular tolerances.



**Fig. 21.4** General tolerance specified as a note on a drawing or within a drawing frame.

The method shown in Fig. 21.1 is perhaps the clearest way of expressing limits of size on a drawing, since the upper and lower limits are quoted, and the machine operator is not involved in mental arithmetic. The dimensions are quoted in logical form, with the upper limit above the lower limit and both to the same number of decimal places.

As an alternative to the method above, the basic size may be quoted and the tolerance limits added as in Fig. 21.2. It is not necessary to express the nominal dimension to the same number of decimal places as the limits.

Fits can be taken directly from those tabulated in BS 4500, 'ISO limits and fits', and, in order to indicate the grade of fit, the following alternative methods of dimensioning a hole may be used:

Similarly, a shaft may be dimensioned as follows:

In cases where a large amount of repetition is involved, information can be given in tabulated form, and a typical component drawing is shown in Fig. 21.3.

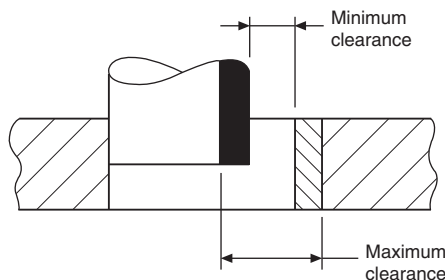
In many cases, tolerances need be only of a general nature, and cover a wide range of dimensions. A box with a standard note is added to the drawing, and the typical examples in Fig. 21.4 are self-explanatory.

Engineering fits between two mating parts can be divided into three types:

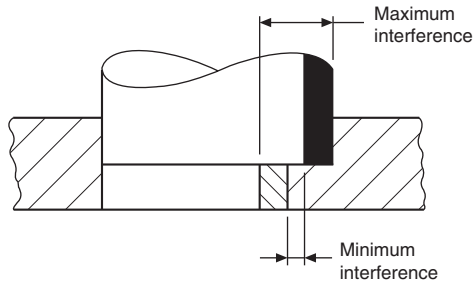
1. A *clearance fit* (Fig. 21.5), in which the shaft is always smaller than the hole into which it fits.
2. An *interference fit* (Fig. 21.6), in which the shaft is always bigger than the hole into which it fits.
3. A *transition fit* (Fig. 21.7), in which the shaft may be either bigger or smaller than the hole into which it fits – it will therefore be possible to get interference or clearance fits in one group of assemblies.

It will be appreciated that, as the degree of accuracy required for each dimension increases, the cost of production to maintain this accuracy increases at a sharper rate.

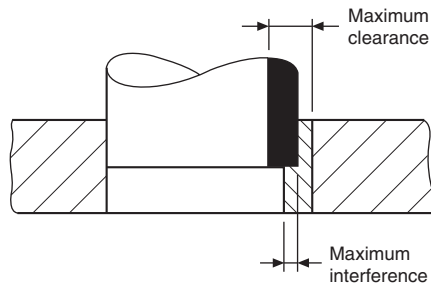
Fig. 21.8 shows the approximate relationship between cost and tolerance. For all applications, the manufacturing tolerance should be the largest possible which permits satisfactory operation.



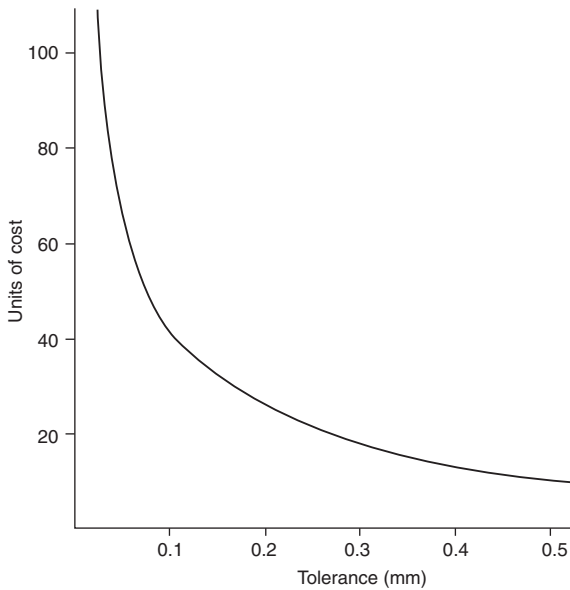
**Fig. 21.5** Clearance fits – allowance always positive.



**Fig. 21.6** Interference fits – allowance always negative.



**Fig. 21.7** Transition fit – allowance may be positive or negative.



**Fig. 21.8** Approximate relationship between production cost and manufacturing tolerance.

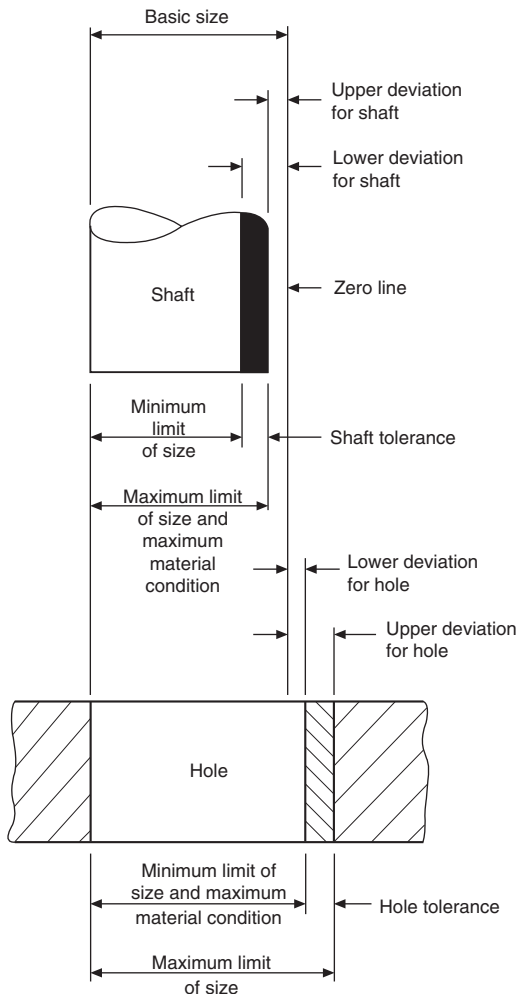
## Elements of interchangeable systems (Fig. 21.9)

*Nominal size* – This is the size by which a component is referred to as a matter of convenience, i.e. 25, 50, and 60 mm thread.

*Actual size* – This is the measured size.

*Basic size* – This is the size in relation to which all limits of size are fixed, and will be the same for both the male and female parts of the fit.

*Limits of size* – These are the maximum and minimum permissible sizes acceptable for a specific dimension.



**Fig. 21.9** Elements of interchangeable systems.

*Tolerance* — This is the total permissible variation in the size of a dimension, and is the difference between the upper and lower acceptable dimensions.

*Allowance* — This concerns mating parts, and is the difference between the high limit of size of the shaft and the low limit of size of its mating hole. An allowance may be positive or negative.

*Grade* — This is an indication of the tolerance magnitude: the lower the grade, the finer will be the tolerance.

*Deviation* — This is the difference between the maximum, minimum, or actual size of a shaft or hole and the basic size.

*Maximum Material Condition (MMC)* — This is the maximum limit of an external feature; for example, a shaft manufactured to its high limits would contain the maximum amount of material. It is also the minimum limit on an internal feature; for example, a component which has a hole produced to its lower limit of size would have the minimum of material removed and remain in its maximum metal condition.

*Minimum or Least Material Condition (LMC)* — This is the minimum limit of an external feature; for example a shaft manufactured to its low limits would contain the minimum amount of material. It is also the maximum limit on an internal feature; for example a hole produced to its maximum limit would have the maximum amount of material removed and remain in its minimum material condition.

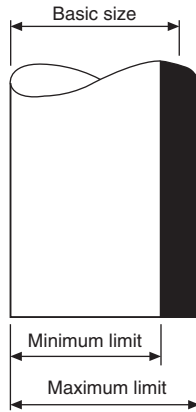
## Unilateral and bilateral limits

Fig. 21.10 shows an example of unilateral limits, where the maximum and minimum limits of size are disposed on the same side of the basic size. This system is preferred since the basic size is used for the GO limit gauge; changes in the magnitude of the tolerance affect only the size of the other gauge dimension, the NOT GO gauge size.

Fig. 21.11 shows an example of bilateral limits, where the limits are disposed above and below the basic size.



Fig. 21.10 Unilateral limits.



**Fig. 21.11** Bilateral limits.

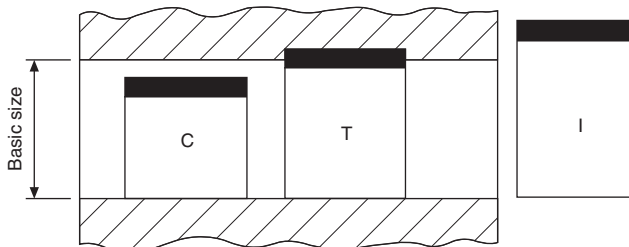
## Bases of fits

The two bases of a system of limits and fits are:

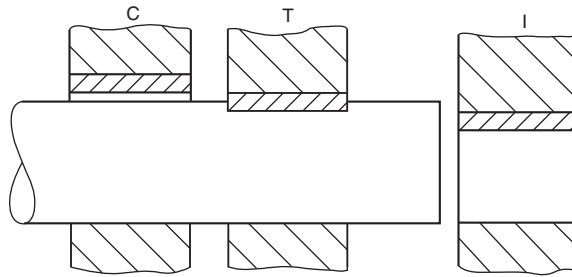
- (a) the hole basis
- (b) the shaft basis.

*Hole basis* (Fig. 21.12) – In this system, the basic diameter of the hole is constant while the shaft size varies according to the type of fit. This system leads to greater economy of production, as a single drill or reamer size can be used to produce a variety of fits by merely altering the shaft limits. The shaft can be accurately produced to size by turning and grinding. Generally it is usual to recommend hole-base fits, except where temperature may have a detrimental effect on large sizes.

*Shaft basis* (Fig. 21.13) – Here the hole size is varied to produce the required class of fit with a basic-size shaft. A series of drills and reamers is required for this system; therefore it tends to be costly. It may, however, be necessary to use it where different fits are required along a long shaft. This BSI data sheet 4500A gives a selection of ISO fits on the hole basis, and data sheet 4500B gives a selection of shaft-basis fits extracted from BS 4500, the current Standard on limits and fits.



**Fig. 21.12** Hole-basis fits: C – clearance, T – transition, I – interference.



**Fig. 21.13** Shaft-basis fits: C – clearance, T – transition, I – interference.

The ISO system contained in BS 4500 gives an extensive selection of hole and shaft tolerances to cover a wide range of applications. It has been found, however, that in the manufacture of many standard engineering components a limited selection of tolerances is adequate. These are provided on the data sheets referred to above. Obviously, by using only a selected range of fits, economic advantages are obtained from the reduced tooling and gauging facilities involved.

## Selected ISO fits – hole basis (extracted from BS 4500)

BS EN 20286 Part 1 describes the ISO system of limits and fits, providing the basis of tolerances, deviations and fits. BS EN 20286 Part 2 provides tables of standard tolerance grades and limit deviations for holes and shafts. Both of these Standards have replaced BS 4500 (which has been withdrawn by BSI). However, the information contained in BS 4500 is identical to that in the BS EN 20286 series and many engineers still use the BS 4500A (hole basis) and BS 4500B (shaft basis) data sheets because they are easier to read and include diagrams of the relationships between a hole and a shaft for commonly applied fits in the clearance, transition and interference classes. For this publication, reference is still made to BS 4500 as are the data sheets reproduced on the following pages.

The ISO system provides a great many hole and shaft tolerances so as to cater for a very wide range of conditions. However, experience shows that the majority of fit conditions required for normal engineering products can be provided by a quite limited selection of tolerances. The following selected hole and shaft tolerances have been found to be commonly applied:

- selected hole tolerances: H7 H8 H9 H11;
- selected shaft tolerances: c11 d10 e9 f7 g6 h6 k6 n6 p6 s6.

Table 21.1 shows a range of fits derived from these selected hole and shaft tolerances. As will be seen, it covers fits from loose clearance to heavy interference, and it may therefore be found to be suitable for most normal requirements. Many users may in fact find that their needs are met by a further selection within this selected range.

**Table 21.1** ISO fits - hole and shaft basis.

Extracted from BS 4500 : 1969		BRITISH STANDARD																Data Sheet 4500A					
		SELECTED ISO FITS—HOLE BASIS																Issue 1, February 1970 confirmed August 1985					
Diagram to scale for 25 mm diameter		Clearance fits										Transition fits				Interference fits				Holes  Shafts			
		H11	H9	H9	H8	H7	H7	H7	k6	H7	n6	H7	p6	H7	s6								
Nominal sizes		Tolerance		Tolerance		Tolerance		Tolerance		Tolerance		Tolerance		Tolerance		Tolerance		Nominal sizes					
Over	To	H11	c11	H9	d10	H9	e9	H8	f7	H7	g6	H7	h6	H7	k6	H7	n6	H7	p6	H7	s6	Over	To
mm	mm	0.001 mm		0.001 mm		0.001 mm		0.001 mm		0.001 mm		0.001 mm		0.001 mm		0.001 mm		0.001 mm		0.001 mm		mm	mm
—	3	+60 0	-60 -120	+25 0	-20 -60	+25 0	-14 -39	+14 0	-6 -16	+10 0	-2 -8	+10 0	-6 -10	+10 0	+6 +10	+10 0	+10 +4	+10 0	+12 +6	+10 0	+20 +14	—	3
3	6	+75 0	-70 -145	+30 0	-30 -78	+30 0	-20 -50	+18 0	-10 -28	+12 0	-4 -12	+12 0	-8 -12	+12 0	+9 +1	+12 0	+16 +8	+12 0	+20 +12	+12 0	+27 +19	3	6
6	10	+90 0	-80 -170	+36 0	-40 -98	+36 0	-25 -61	+22 0	-13 -31	+15 0	-5 -14	+15 0	-9 -14	+15 0	+10 +1	+15 +10	+19 +10	+15 +10	+24 +15	+15 +10	+32 +23	6	10
10	18	+110 0	-95 -205	+43 0	-30 -120	+43 0	-32 -75	+27 0	-16 -34	+18 0	-6 -17	+18 0	-11 -17	+18 +1	+12 +1	+18 +12	+23 +12	+18 +18	+29 +18	+18 +18	+30 +28	10	18
18	30	+130 0	-110 -240	+52 0	-45 -149	+52 0	-40 -92	+33 0	-20 -41	+21 0	-7 -20	+21 0	-13 -20	+21 +2	+15 +2	+21 +15	+28 +13	+21 +22	+35 +22	+21 +22	+48 +35	18	30
30	40	+160 0	-120 -280	+62 0	-80 -180	+62 0	-50 -112	+39 0	-25 -50	+25 0	-9 -25	+25 0	-16 -25	+25 0	+18 +2	+25 +17	+33 +26	+25 +26	+42 +26	+25 +26	+59 +43	30	40
40	50	+160 0	-130 -290	+62 0	-80 -180	+62 0	-50 -112	+39 0	-25 -50	+25 0	-9 -25	+25 0	-16 -25	+25 0	+18 +2	+25 +17	+33 +26	+25 +26	+42 +26	+25 +26	+59 +43	40	50
50	65	+190 0	-140 -300	+74 0	-100 -220	+74 0	-60 -134	+46 0	-30 -60	+30 0	-10 -29	+30 0	-19 -29	+30 +2	+30 +2	+30 +20	+30 +20	+30 +32	+30 +32	+30 +32	+72 +59	50	65
65	80	+190 0	-150 -340	+74 0	-100 -220	+74 0	-60 -134	+46 0	-30 -60	+30 0	-10 -29	+30 0	-19 -29	+30 +2	+30 +2	+30 +20	+30 +20	+30 +32	+30 +32	+30 +32	+72 +59	65	80
80	100	+220 0	-170 -390	+87 0	-120 -260	+87 0	-87 -159	+72 +4	-36 -71	+35 0	-12 -34	+35 0	-22 -34	+35 +3	+35 +3	+35 +23	+35 +23	+35 +37	+35 +37	+35 +37	+80 +71	80	100
100	120	+220 0	-180 -420	+87 0	-120 -260	+87 0	-87 -159	+72 +4	-36 -71	+35 0	-12 -34	+35 0	-22 -34	+35 +3	+35 +3	+35 +23	+35 +23	+35 +37	+35 +37	+35 +37	+80 +71	100	120
120	140	+250 0	-200 -450	+100 0	-145 -305	+100 0	-84 -185	+63 +3	-43 -83	+40 0	-14 -39	+40 0	-25 -39	+40 +3	+40 +3	+40 +27	+40 +27	+40 +27	+40 +27	+40 +27	+117 +92	120	140
140	160	+250 0	-210 -460	+100 0	-145 -305	+100 0	-84 -185	+63 +3	-43 -83	+40 0	-14 -39	+40 0	-25 -39	+40 +3	+40 +3	+40 +27	+40 +27	+40 +27	+40 +27	+40 +27	+117 +92	140	160
160	180	+250 0	-230 -480	+100 0	-145 -305	+100 0	-84 -185	+63 +3	-43 -83	+40 0	-14 -39	+40 0	-25 -39	+40 +3	+40 +3	+40 +27	+40 +27	+40 +27	+40 +27	+40 +27	+117 +92	160	180
180	200	+290 0	-240 -530	+115 0	-170 -355	+115 0	-100 -215	+72 +4	-50 -96	+46 0	-15 -44	+46 0	-29 -44	+46 +4	+46 +4	+46 +31	+46 +31	+46 +31	+46 +31	+46 +31	+151 +122	180	200
200	225	+290 0	-260 -550	+115 0	-170 -355	+115 0	-100 -215	+72 +4	-50 -96	+46 0	-15 -44	+46 0	-29 -44	+46 +4	+46 +4	+46 +31	+46 +31	+46 +31	+46 +31	+46 +31	+151 +122	200	225
225	250	+290 0	-280 -570	+115 0	-170 -355	+115 0	-100 -215	+72 +4	-50 -96	+46 0	-15 -44	+46 0	-29 -44	+46 +4	+46 +4	+46 +31	+46 +31	+46 +31	+46 +31	+46 +31	+151 +122	225	250
250	280	+320 0	-300 -620	+130 0	-190 -400	+130 0	-110 -240	+81 +4	-56 -108	+52 0	-17 -49	+52 0	+32 -49	+52 0	+32 +4	+52 0	+66 +34	+52 0	+88 +56	+52 +56	+190 +170	250	280
280	315	+320 0	-330 -650	+130 0	-190 -400	+130 0	-110 -240	+81 +4	-56 -108	+52 0	-17 -49	+52 0	+32 -49	+52 0	+32 +4	+52 0	+66 +34	+52 0	+88 +56	+52 +56	+190 +170	280	315
315	355	+360 0	-360 -720	+140 0	-210 -440	+140 0	-125 -265	+89 +4	-62 -119	+57 0	-18 -54	+57 0	-36 -54	+57 +4	+57 +4	+57 +37	+57 +37	+57 +37	+57 +37	+57 +37	+220 +190	315	355
355	400	+360 0	-400 -760	+140 0	-210 -440	+140 0	-125 -265	+89 +4	-62 -119	+57 0	-18 -54	+57 0	-36 -54	+57 +4	+57 +4	+57 +37	+57 +37	+57 +37	+57 +37	+57 +37	+220 +190	355	400
400	450	+400 0	-440 -840	+155 0	-230 -480	+155 0	-135 -290	+97 +4	-68 -131	+63 0	+63 -60	+63 0	-40 -60	+63 +5	+63 +5	+63 +80	+63 +40	+63 +40	+63 +40	+63 +40	+272 +252	400	450
450	500	+400 0	-480 -880	+155 0	-230 -480	+155 0	-135 -290	+97 +4	-68 -131	+63 0	+63 -60	+63 0	-40 -60	+63 +5	+63 +5	+63 +80	+63 +40	+63 +40	+63 +40	+63 +40	+272 +252	450	500

BRITISH STANDARDS INSTITUTION, 2 Park Street, London, W1A 2BS  
SBN: 380 05766 6

Continued

**Table 21.1 ISO fits - hole and shaft basis.—cont'd**

Extracted from BS 4500 : 1969		BRITISH STANDARD														Data Sheet 4500B Issue 1, February 1970							
Diagram to scale for 25 mm diameter		Clearance fits										Transition fits				Interference fits				Holes  Shafts			
		C 11		D 10		E 9		F 8		G 7		H 7		K 7		N 7		P 7				S 7	
Nominal sizes	Tolerance	Tolerance	Tolerance	Tolerance	Tolerance	Tolerance	Tolerance	Tolerance	Tolerance	Tolerance	Tolerance	Tolerance	Tolerance	Tolerance	Tolerance	Tolerance	Tolerance	Tolerance	Tolerance	Nominal sizes	Tolerance		
Over mm	To mm	h11 0.001 mm	C11 0.001 mm	h9 0.001 mm	D10 0.001 mm	h9 0.001 mm	E9 0.001 mm	h7 0.001 mm	F8 0.001 mm	h6 0.001 mm	G7 0.001 mm	h6 0.001 mm	H7 0.001 mm	h6 0.001 mm	K7 0.001 mm	h6 0.001 mm	N7 0.001 mm	h6 0.001 mm	P7 0.001 mm	h6 0.001 mm	S7 0.001 mm	Over mm	To mm
—	3	0 -60	+120 +60	0 -25	+60 +20	0 -25	+39 +14	0 -10	+20 +6	0 -6	+12 +2	0 -6	+10 0	0 -6	0 -10	0 -6	-4 -6	0 -6	-6 -6	0 -6	-14 -24	—	3
3	6	0 -25	+145 +70	0 -30	+78 +30	0 -30	+50 +20	0 -12	+28 +10	0 -8	+16 +4	0 -8	+12 0	0 -8	0 -10	0 -8	-4 -8	0 -8	-8 -20	0 -8	-15 -27	3	6
6	10	0 -90	+170 +80	0 -36	+98 +40	0 -36	+61 +25	0 -15	+35 +13	0 -9	+20 +5	0 -9	+15 0	0 -9	+5 0	0 -9	-4 -9	0 -9	-9 -24	0 -9	-17 -32	6	10
10	18	0 -110	+205 +95	0 -43	+120 +50	0 -43	+75 +32	0 -18	+43 +16	0 -11	+24 +6	0 -11	+18 0	0 -11	+6 -12	0 -11	-5 -23	0 -11	-11 -29	0 -11	-21 -39	10	18
18	30	0 -130	+240 +110	0 -52	+148 +65	0 -52	+92 +40	0 -21	+55 +20	0 -13	+28 +7	0 -13	+21 0	0 -13	0 -15	0 -13	-7 -28	0 -13	-14 -35	0 -13	-27 -48	18	30
30	40	0 -160	+280 +120	0 -62	+180 +80	0 -62	+112 +50	0 -25	+64 +25	0 -16	+34 +9	0 -16	+25 0	0 -16	+7 -18	0 -16	-8 -33	0 -16	-17 -42	0 -16	-34 -59	30	40
40	50	0 -160	+290 +130	0 -62	+180 +80	0 -62	+112 +50	0 -25	+64 +25	0 -16	+34 +9	0 -16	+25 0	0 -16	+7 -18	0 -16	-8 -33	0 -16	-17 -42	0 -16	-34 -59	40	50
50	65	0 -180	+330 +140	0 -74	+220 +100	0 -74	+134 +60	0 -30	+76 +30	0 -19	+40 +10	0 -19	+30 0	0 -19	+9 -21	0 -19	-9 -39	0 -19	-21 -51	0 -19	-42 -72	50	65
65	80	0 -190	+340 +150	0 -87	+240 +120	0 -87	+148 +72	0 -35	+80 +36	0 -22	+40 +12	0 -22	+30 0	0 -22	+9 -25	0 -22	-9 -45	0 -22	-21 -59	0 -22	-42 -72	65	80
80	100	0 -220	+390 +170	0 -87	+260 +120	0 -87	+159 +72	0 -35	+90 +36	0 -22	+47 +12	0 -22	+35 0	0 -22	+10 -25	0 -22	-10 -45	0 -22	-24 -59	0 -22	-42 -72	80	100
100	120	0 -220	+400 +180	0 -87	+260 +120	0 -87	+159 +72	0 -35	+90 +36	0 -22	+47 +12	0 -22	+35 0	0 -22	+10 -25	0 -22	-10 -45	0 -22	-24 -59	0 -22	-42 -72	100	120
120	140	0 -250	+450 +210	0 -100	+305 +145	0 -100	+185 +85	0 -40	+106 +43	0 -25	+54 +14	0 -25	+40 0	0 -25	+12 -28	0 -25	-12 -52	0 -25	-28 -68	0 -25	-42 -72	120	140
140	160	0 -250	+460 +230	0 -100	+305 +145	0 -100	+185 +85	0 -40	+106 +43	0 -25	+54 +14	0 -25	+40 0	0 -25	+12 -28	0 -25	-12 -52	0 -25	-28 -68	0 -25	-42 -72	140	160
160	180	0 -250	+480 +240	0 -115	+355 +170	0 -115	+215 +100	0 -46	+122 +50	0 -29	+61 +15	0 -29	+46 0	0 -29	+13 -33	0 -29	-14 -60	0 -29	-33 -79	0 -29	-42 -72	160	180
180	200	0 -290	+530 +250	0 -115	+355 +170	0 -115	+215 +100	0 -46	+122 +50	0 -29	+61 +15	0 -29	+46 0	0 -29	+13 -33	0 -29	-14 -60	0 -29	-33 -79	0 -29	-42 -72	180	200
200	225	0 -290	+550 +260	0 -115	+355 +170	0 -115	+215 +100	0 -46	+122 +50	0 -29	+61 +15	0 -29	+46 0	0 -29	+13 -33	0 -29	-14 -60	0 -29	-33 -79	0 -29	-42 -72	200	225
225	250	0 -290	+570 +280	0 -115	+355 +170	0 -115	+215 +100	0 -46	+122 +50	0 -29	+61 +15	0 -29	+46 0	0 -29	+13 -33	0 -29	-14 -60	0 -29	-33 -79	0 -29	-42 -72	225	250
250	280	0 -320	+620 +300	0 -130	+400 +190	0 -130	+240 +110	0 -52	+137 +56	0 -32	+62 +17	0 -32	+52 0	0 -32	+16 -36	0 -32	-14 -66	0 -32	-36 -88	0 -32	-42 -72	250	280
280	315	0 -320	+650 +330	0 -130	+400 +190	0 -130	+240 +110	0 -52	+137 +56	0 -32	+62 +17	0 -32	+52 0	0 -32	+16 -36	0 -32	-14 -66	0 -32	-36 -88	0 -32	-42 -72	280	315
315	355	0 -360	+720 +360	0 -140	+440 +210	0 -140	+265 +125	0 -57	+151 +62	0 -36	+75 +18	0 -36	+57 0	0 -36	+17 -40	0 -36	-16 -73	0 -36	-41 -98	0 -36	-42 -72	315	355
355	400	0 -360	+760 +400	0 -140	+440 +210	0 -140	+265 +125	0 -57	+151 +62	0 -36	+75 +18	0 -36	+57 0	0 -36	+17 -40	0 -36	-16 -73	0 -36	-41 -98	0 -36	-42 -72	355	400
400	450	0 -400	+840 +440	0 -155	+480 +230	0 -155	+290 +135	0 -63	+165 +68	0 -40	+83 +20	0 -40	+63 0	0 -40	+18 -45	0 -40	-17 -80	0 -40	-45 -108	0 -40	-42 -72	400	450
450	500	0 -400	+880 +480	0 -155	+480 +230	0 -155	+290 +135	0 -63	+165 +68	0 -40	+83 +20	0 -40	+63 0	0 -40	+18 -45	0 -40	-17 -80	0 -40	-45 -108	0 -40	-42 -72	450	500

It should be noted, however, that this table is offered only as an example of how a restricted selection of fits can be made. It is clearly impossible to recommend selections of fits which are appropriate to all sections of industry, but it must be emphasized that a user who decides upon a selected range will always enjoy the economic advantages this conveys. Once they have installed the necessary tooling and gauging facilities, they can combine his selected hole and shaft tolerances in different ways without any additional investment in tools and equipment.

For example, if it is assumed that the range of fits shown in the table has been adopted but that, for a particular application the fit H8-f7 is appropriate but provides rather too much variation, the hole tolerance H7 could equally well be associated with the shaft f7 and may provide exactly what is required without necessitating any additional tooling.

For most general applications, it is usual to recommend hole-basis fits, as, except in the realm of very large sizes where the effects of temperature play a large part, it is usually considered easier to manufacture and measure the male member of a fit, and it is thus desirable to be able to allocate the larger part of the tolerance available to the hole and adjust the shaft to suit.

In some circumstances, however, it may in fact be preferable to employ a shaft basis. For example, in the case of driving shafts where a single shaft may have to accommodate a variety of accessories such as couplings, bearings and collars, it is preferable to maintain a constant diameter for the permanent member, which is the shaft, and vary the bore of the accessories. For use in applications of this kind, a selection of shaft basis fits is provided in data sheet BS 4500B.

*Note:* Data sheet 4500A (Table 21.1) refers to hole basis fits.

Data sheet 4500B (Table 21.1) refers to shaft basis fits.

## Interpretations of limits of size in relation to form

There are two ways of interpreting the limits of size of an individual feature, which are known by:

1. the Principle of Independency, where the limits of size apply to local two point measurements of a feature regardless of form;
2. the Envelope Requirement, also known as the *Taylor Principle*, where the limits of size of an individual feature are intended to have a mutual dependency of size and form.

Fig. 21.14A–C illustrate the Principle of Independency.

Fig. 21.15A–E illustrate the Envelope Requirement.

The drawing indication in Fig. 21.15A shows a linear tolerance followed by the symbol  $\text{Ⓜ}$ . Two functional requirements are implied by the use of the symbol:

1. That the surface of the cylindrical feature is contained within an envelope of perfect form at maximum material size of  $\text{Ø}120$ .

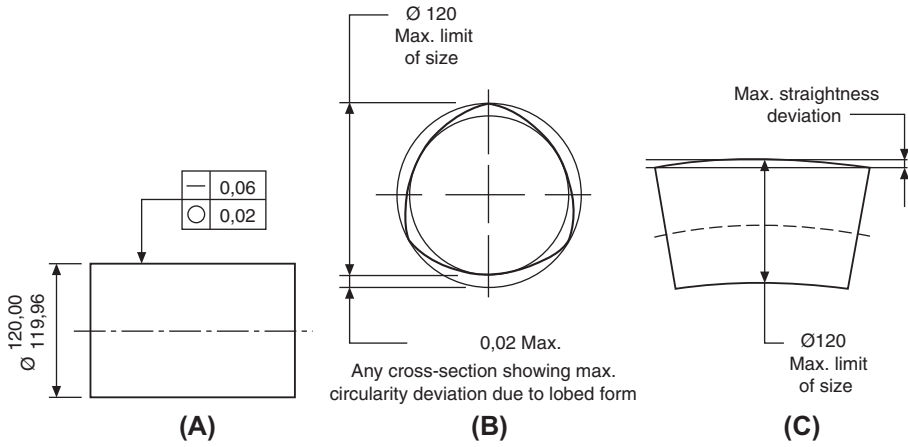


Fig. 21.14 Principle of independency.

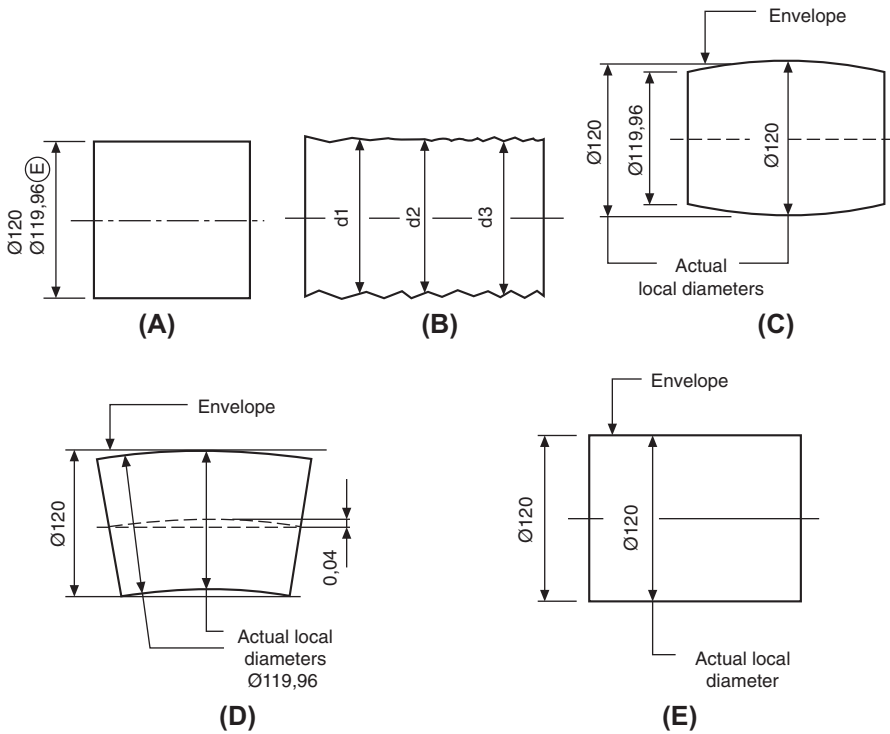


Fig. 21.15 The envelope requirement.

2. That no actual local size shall be less than  $\text{Ø}119,96$ . An exaggerated view of the feature in Fig. 21.15B, shows that each actual local diameter of the shaft must remain within the size tolerance of 0.04 and may vary between  $\text{Ø}120$  and  $\text{Ø}119,96$ .

In the examples which follow, the entire shaft must remain within the boundary of the  $\text{Ø}120$  envelope cylinder of perfect form.

It follows therefore that the shaft will be perfectly cylindrical when all actual local diameters are at the maximum material size of  $\text{Ø}120$ .

Maximum material condition. For further reading see ISO 2692 which states: If for functional and economic reasons there is a requirement for the mutual dependency of the size and orientation or location of the feature(s), then the maximum material principle  $\text{Ⓜ}$  may be applied.

# Geometrical tolerancing and datums

22

## Geometrical tolerances

The object of this section is to illustrate and interpret in simple terms the advantages of applying geometrical tolerances on engineering drawings, and also to show that, when correctly used, they ensure that communications between the design office and the workshop are complete and incapable of misinterpretation, regardless of any language barrier. In this chapter and Chapter 23, the basic rules are presented, readers are recommended to study ISO1101 and ISO5459 for a complete understanding.

## Applications

Geometrical tolerances are applied over and above normal dimensional tolerances when it is necessary to control more precisely the form or shape of some feature of a manufactured part, because of the particular duty that the part has to perform. In the past, the desired qualities would have been obtained by adding to drawings such expressions as ‘surfaces to be true with one another’, ‘surfaces to be square with one another’, ‘surfaces to be flat and parallel’, etc., and leaving it to workshop tradition to provide a satisfactory interpretation of the requirements.

## Advantages

Geometrical tolerances are used to convey in a brief and precise manner complete geometrical requirements on engineering drawings. They should always be considered for surfaces which come into contact with other parts, especially when close tolerances are applied to the features concerned.

No language barrier exists, as the symbols used are in agreement with published recommendations of the International Organization for Standardization (ISO) and have been internationally agreed. BS 8888 incorporates these symbols.

In The past, it was recommended that geometrical tolerances should be applied only when real advantages result, when normal methods of dimensioning are considered inadequate to ensure that the design function is kept, especially where repeatability must be guaranteed. It is still true that indiscriminate use of geometrical tolerances could increase costs in manufacture and inspection, and occasionally manufacturing areas do not fully appreciate the geometrical tolerancing principles and wrongly assume that the application of geometrical tolerances means a precision part with tight tolerances (probably as a result of misunderstanding the use of Theoretical Exact

Dimension (TED)) and its associated tolerance. However, if geometrical tolerances are applied appropriately i.e. as wide as the function of the design allows then in fact cost savings will be possible.

Readers are encouraged to consider the method described in Chapter 23 of replacing general tolerances (i.e.  $\pm$  applied either by a general note or by individual dimension) by the use of TED's and a few specific geometrical tolerances.

## General rules

The symbols relating to geometrical characteristics are shown in Fig. 22.1A with additional symbols used in tolerancing in Fig. 22.1B and Fig 22.1C. Examination of the various terms – flatness, straightness, concentricity, etc. – used to describe the geometrical characteristics shows that one type of geometrical tolerance can control another form of geometrical error.

For example, a positional tolerance can control perpendicularity and straightness; parallelism, perpendicularity, and angularity tolerances can control flatness.

The use of geometrical tolerances does not involve or imply any particular method of manufacture or inspection. Geometrical tolerances shown in this book, in keeping with international conventions, must be met regardless of feature size unless modified by one of the following conditions:

- (a) Maximum material condition, denoted by the symbol, describes a part, which contains the maximum amount of material, i.e. the minimum size hole or the maximum size shaft.
- (b) Least material condition, denoted by the symbol, describes a part, which contains the minimum amount of material, i.e. the maximum size hole or the minimum size shaft.

## Theoretically Exact Dimensions (TEDs)

These dimensions are identified by enclosure in rectangular boxes, e.g.  $\boxed{50}$   $\boxed{60^\circ}$   $\boxed{\text{Ø}30}$  and are commonly known as *boxed* dimensions or *true position* dimensions. They define the true position of a hole, slot, boss profile, etc.

TEDs are never individually toleranced but are always accompanied by a positional or zone tolerance specified within the tolerance frame referring to the feature (see Fig. 22.2).

*Note:* If two or more groups of features are shown on the same axis, they shall be considered to be a single pattern when not related to a datum.

## Definitions

*Limits:* The maximum and minimum dimensions for a given feature are known as the *limits*; for example,  $20 \pm 0.1$ . The upper and lower limits of size are 20.1 and 19.9 mm, respectively.

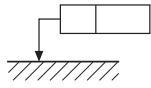
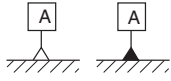








Type of tolerance	Characteristics to be toleranced	Symbol	Datum needed	Applications
Form	Straightness		No	A straight line. The edge or axis of a feature.
	Flatness		No	A plane surface.
	Roundness		No	The periphery of a circle. Cross-section of a bore, cylinder, cone or sphere.
	Cylindricity		No	The combination of circularity, straightness and parallelism of cylindrical surfaces. Mating bores and plungers.
	Profile of a line		No	The profile of a straight or irregular line.
	Profile of a surface		No	The profile of a straight or irregular surface.
Orientation	Parallelism		Yes	Parallelism of a feature related to a datum. Can control flatness when related to a datum.
	Perpendicularity		Yes	Surfaces, axes, or lines positioned at right angles to each other.
	Angularity		Yes	The angular displacement of surfaces, axes, or lines from a datum.
	Profile of a line		Yes	The profile of a straight or irregular line positioned by theoretical exact dimensions with respect to datum plane(s).
	Profile of a surface		Yes	The profile of a straight or irregular surface positioned by theoretical exact dimensions with respect to datum plane(s).
Location	Position		See note below	The deviation of a feature from a true position.
	Concentricity and coaxiality		Yes	The relationship between two circles having a common centre or two cylinders having a common axis.
	Symmetry		Yes	The symmetrical position of a feature related to a datum.
	Profile of a line		Yes	The profile of a straight or irregular line positioned by theoretical exact dimensions with respect to datum plane(s).
	Profile of a surface		Yes	The profile of a straight or irregular surface positioned by theoretical exact dimensions with respect to datum plane(s).
Runout	Circular runout		Yes	The position of a point fixed on a surface of a part which is rotated 360° about its datum axis.
	Total runout		Yes	The relative position of a point when traversed along a surface rotating about its datum axis.

**Fig. 22.1A** Symbols relating to geometrical characteristics.

*Tolerance:* The algebraic difference between the upper and lower limit of size is known as the *tolerance*. In the example above, the tolerance is 0.2 mm. The tolerance is the amount of variation permitted.

*Nominal dimension:* Limits and tolerances are based on ‘nominal dimensions’, which are target dimensions. In practice there is no such thing as a nominal dimension, since no part can be manufactured to a theoretical exact size.

**Additional symbols**

Description	Symbols
Toleranced feature indication	
Datum feature indication	
Datum target indication	
Theoretically exact dimension	
Projected tolerance zone	
Maximum material requirement	
Least material requirement	
Free state condition (non-rigid parts)	
All around profile	
Envelope requirement	
Common zone	CZ
Minor diameter	LD
Major diameter	MD
Pitch diameter	PD
Line element	LE
Not convex	NC
Any cross-section	ACS

**Fig. 22.1B** Additional symbols used with geometrical tolerances.

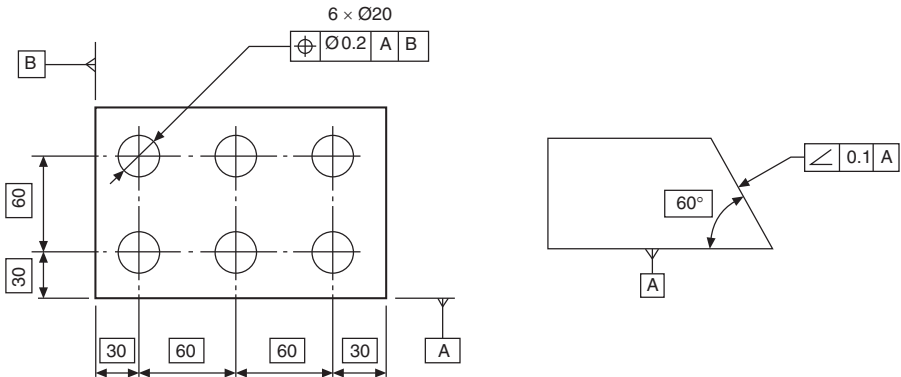
Minor diameter	LD
Major diameter	MD
Pitch diameter	PD
Line element	LE
Not convex	NC
Any cross section	ACS
Unilateral or unequally disposed tolerance	UZ
Median feature	Ⓐ
All around (profile)	
Between (two points)	
From ... to (two points)	
Counterbore or Spotface	
Countersink	
Deep / Depth	
Intersection plane	
Orientation plane	
Direction feature	
Collection plane	
Orientation Condition only Note: complimentary indication added to a datum indicator within a tolerance frame to identify that the datum is used to control orientation only and not location. The symbol can be omitted where the geometrical tolerance controls only orientation i.e. perpendicular (see figure 23.2)	

**Fig. 22.1C** Additional symbols used with geometrical tolerances.

The limits referred to above can be set in two ways:

- (a) *unilateral* limits – limits set wholly above or below the nominal size;
- (b) *bilateral* limits – limits set partly above and partly below the nominal size.

*Geometrical tolerance:* These tolerances specify the maximum error of a component’s geometrical characteristic, over its whole dimensioned length or surface. Defining a zone in which the feature may lie does this.



**Fig. 22.2** Application of TED's and associated geometrical tolerances.

*Tolerance zone:* A tolerance zone is the space in which any deviation of the feature must be contained, for example:

- the space within a circle;
- the space between two concentric circles;
- the space between two equidistant lines or two parallel straight lines;
- the space within a cylinder;
- the space between two coaxial cylinders;
- the space between two equidistant surfaces or two parallel planes;
- the space within a sphere.

The tolerance applies to the whole extent of the considered feature unless otherwise specified.

## Method of indicating geometrical tolerances on drawings

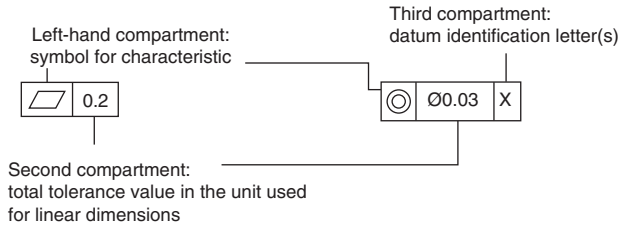
Geometrical tolerances are indicated by stating the following details in compartments in a rectangular frame:

- (a) the characteristic symbol, for single or related features;
- (b) the tolerance value;
  - (i) preceded by  $\varnothing$  if the zone is circular or cylindrical,
  - (ii) preceded by  $S\varnothing$  if the zone is spherical;
- (c) letter or letters identifying the datum or datum systems.

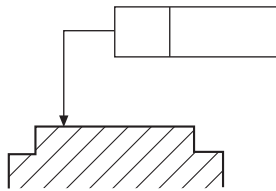
Fig. 22.3 shows examples.

## Methods of applying the tolerance frame to the toleranced feature

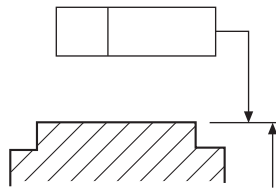
Figs. 22.4 and 22.5 illustrate alternative methods of referring the tolerance to the surface or the plane itself. Note that in Fig. 22.5 the dimension line and frame leader line are offset.



**Fig. 22.3** Tolerance frame compartments.

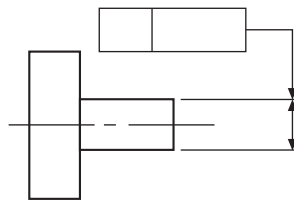


**Fig. 22.4** Attachment of a tolerance applying to a surface.



**Fig. 22.5** Alternative attachment of a tolerance applying to a surface.

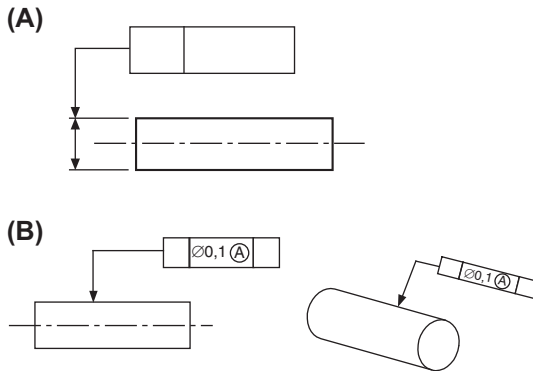
The tolerance frame as shown in Fig. 22.6 refers to the axis or median plane only of the dimensioned feature.



**Fig. 22.6** Attachment of a tolerance applying to an axis or median plane.

Fig. 22.7A illustrates the method of referring the tolerance to the axis or median plane. Note that the dimension line and frame leader line are drawn in line.

Fig. 22.7B illustrates an alternative way of referring to an axis or median feature; this has been introduced to aid the annotation of 3D models (see Chapter 28). In this method the tolerance frame is connected to the feature by a leader line terminating with an arrowhead pointing directly at the surface, but with the addition of the modifier

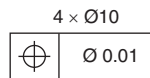


**Fig. 22.7** Alternative attachment of a tolerance applying to an axis or median plane.

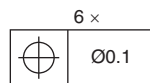
symbol (median feature) placed at the right-hand end of the second compartment of the tolerance frame.

## Procedure for positioning remarks which are related to tolerance

Remarks related to the tolerance, for example '6 x', should be written above the frame (see [Figs. 22.8 and 22.9](#)).



**Fig. 22.8** Positioning additional information relating to a tolerance.



**Fig. 22.9** Positioning additional information relating to a tolerance.

Indications qualifying the feature within the tolerance zone should be written under the tolerance frame (see [Fig. 22.10](#)).



**Fig. 22.10** Positioning qualifying information relating to a feature.

If it is necessary to specify more than one tolerance characteristic for a feature, the tolerance specification should be given in tolerance frames positioned one under the other as shown in [Fig. 22.11](#).

○	0.01	
∥	0.06	B

Fig. 22.11 Example of more than one tolerance characteristic.

## The application of tolerances to a restricted length of a feature

Fig. 22.12 shows the method of applying a tolerance to only a particular part of a feature.

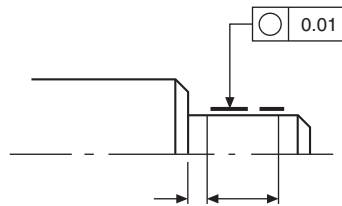


Fig. 22.12 Restricted length.

The tolerance frame in Fig. 22.13 shows the method of applying another tolerance, similar in type but smaller in magnitude, on a shorter length. In this case, the whole flat surface must lie between parallel planes 0.2 apart, but over any length of 180 mm, in any direction, the surface must be within 0.05.

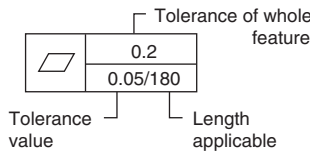


Fig. 22.13 Dual tolerance.

Fig. 22.14 shows the method used to apply a tolerance over a given length; it allows the tolerance to accumulate over a longer length. In this case, straightness tolerance of 0.02 is applicable over a length of 100 mm. If the total length of the feature was 800 mm, then the total permitted tolerance would accumulate to 0.16.

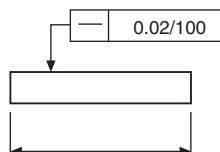


Fig. 22.14 Tolerance per unit length.

## Tolerance zones

The width of the tolerance zone is in the direction of the leader line arrow joining the symbol frame to the tolerated feature unless the tolerance zone is preceded by the symbol  $\emptyset$ . An example is given in Fig. 22.15A.

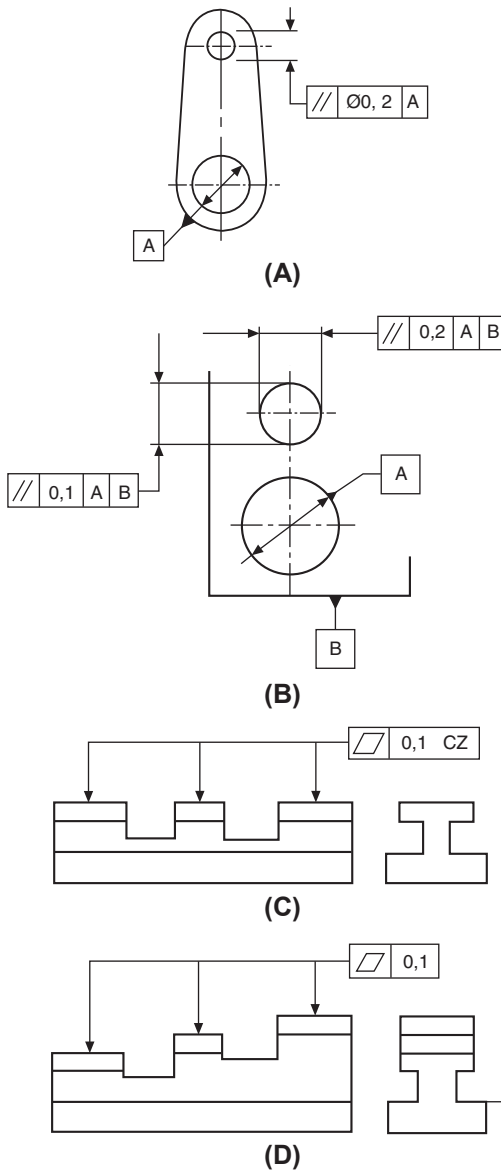


Fig. 22.15 Tolerance zones.

If two tolerances are given, then they are considered to be perpendicular to each other, unless otherwise stated. Fig. 22.15B shows an example.

Fig. 22.15C gives an example where a single tolerance zone is applied to several separate features. In the tolerance frame the symbol 'CZ' is added. CZ is the standard abbreviation for 'Common Zone'.

Fig. 22.15D gives an example where individual tolerance zones of the same valve are applied to several separate features.

## Projected toleranced zone

Fig. 22.16A shows a part section through a flange where it is required to limit the variation in perpendicularity of each hole axis. The method used is to apply a tolerance to a projected zone. The enlargement shows a possible position for the axis through one hole. Each hole axis must lie somewhere within a projected cylinder of  $\varnothing 0.02$  and 30 deep.

As an alternative to indicating the projected tolerance zone using supplemental geometry, the length of projection can also be specified indirectly by adding the value, after the symbol  $\textcircled{P}$ , in the tolerance frame (Fig. 22.16B). This method of indication is only applicable to blind holes.

*Note:* Projected tolerance zones are indicated by the symbol. Note that the zone is projected from the specified datum.

## Datums and Datum Systems

Datums and Datum Systems are used as the basis for establishing the geometric relationship of related features of a workpiece.

### Definitions

*Single datum:* A theoretical exact point, axis, line, plane or a combination of the same (see Figs. 22.17–22.24 for examples of identifying datum features).

*Common datum:* A datum established from two or more datum features considered simultaneously (see Fig. 22.25 B and 22.32).

*Datum system:* Datum established from two or more datum features considered in a specific order (see Fig. 22.26).

*Datum target:* A portion of a datum feature which can be a line, point or an area (see Fig. 22.38).

## Datums

A datum surface on a component should be accurately finished, since other locations or surfaces are established by measuring from the datum. Fig. 22.17 shows a datum surface indicated by the letter A.

In this example, the datum edge is subject to a straightness tolerance of 0.05, shown in the tolerance frame.

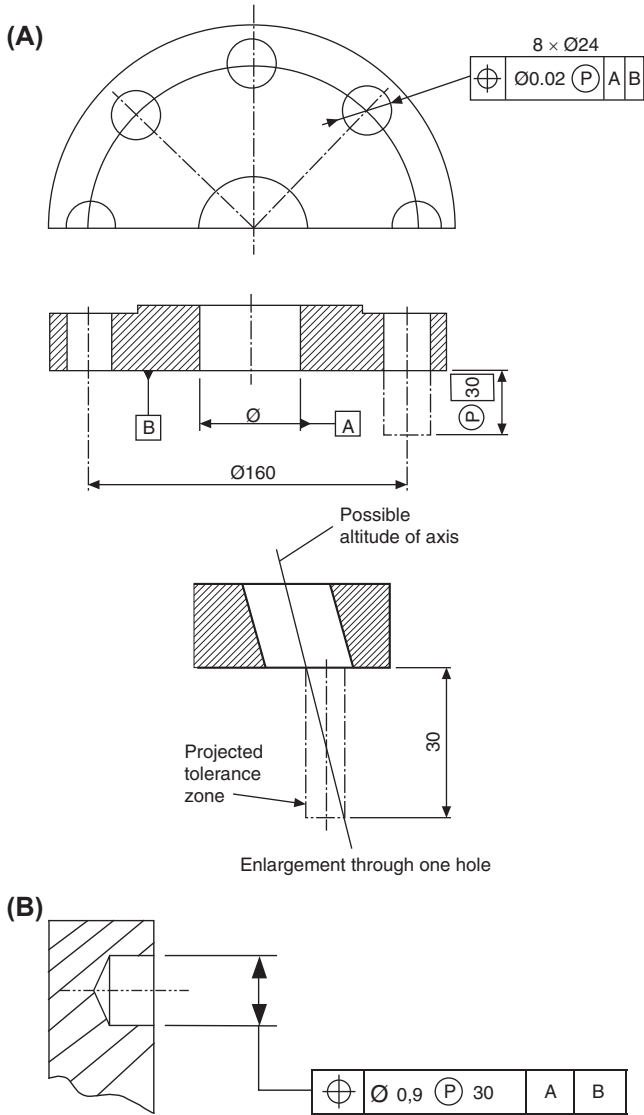


Fig. 22.16 Projected tolerance zone.

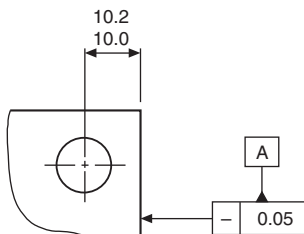
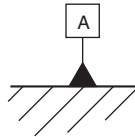


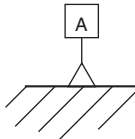
Fig. 22.17 Datum surface, identifier applied to a tolerance frame.

## Methods of specifying datum features

A datum is designated by a capital letter enclosed by a datum box. The box is connected to a solid or a blank datum triangle. There is no difference in understanding between solid or blank datum triangles. Fig. 22.18 and 22.19 show alternative methods of designating a flat surface as Datum A.

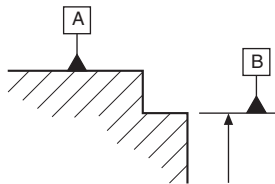


**Fig. 22.18** Direct attachment to surface - filled identifier.



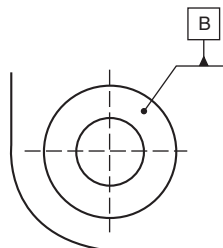
**Fig. 22.19** Direct attachment to surface - open identifier.

Fig. 22.20 illustrates alternative positioning of datum boxes. Datum A is designating the main outline of the feature. The shorter stepped portion Datum B is positioned on an extension line, which is clearly separated from the dimension line.



**Fig. 22.20** Datum surface identifiers direct attachment and extension line attachment.

Fig. 22.21 shows the datum triangle placed on a leader line pointing to a flat surface.



**Fig. 22.21** Datum surface - leader line attachment.

Figs. 22.22–22.24 illustrate the positioning of a datum box on an extension of the dimension line, when the datum is the axis or median plane or a point defined by the dimensioned feature.

Note: If there is insufficient space for two arrowheads, one of them may be replaced by the datum triangle, as shown in Fig. 22.24.

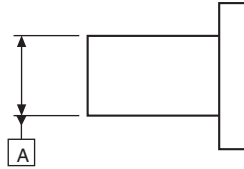


Fig. 22.22 Datum axis or median plane.

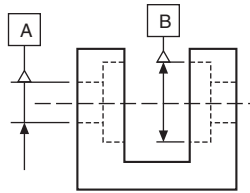


Fig. 22.23 Datum axis or median plane.

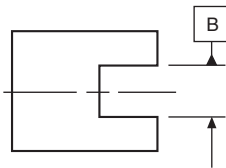


Fig. 22.24 Datum axis or median plane.

Examples of indicating datums in the tolerance frame are shown in Fig. 22.25.

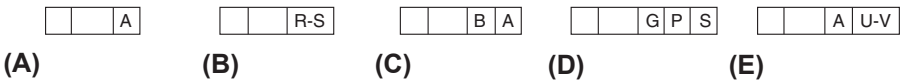
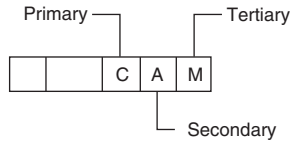


Fig. 22.25 (A) Single datum used alone. (B) Common datum used alone. (C) Two single datums used in a system. (D) Three single datums used in a system. (E) A single datum and a common datum used in a system.

## Datum systems

In a datum system the primary datum is indicated in the third compartment of the tolerance frame; the secondary datum is indicated in the fourth compartment and the tertiary datum is indicated in the fifth compartment (Fig. 22.26).

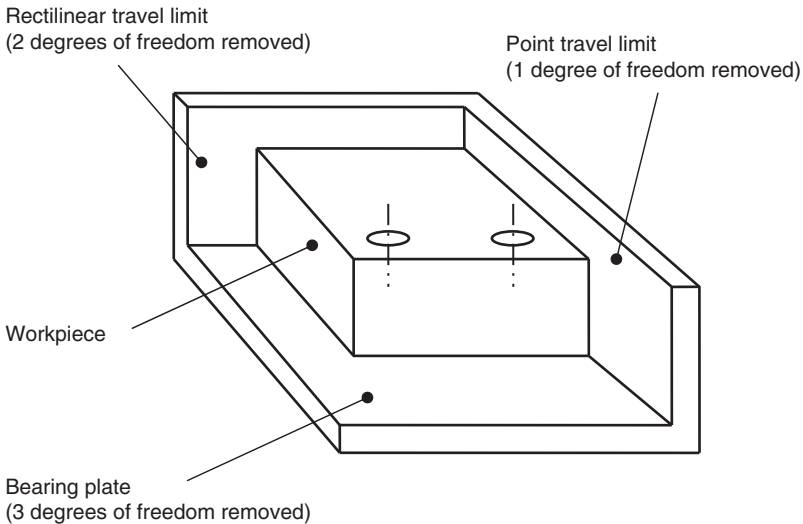


**Fig. 22.26** Indication of a datum system.

Figs. 22.27–22.31 explain the concept, specification and interpretation of a datum system.

### Concept

The positioning of the part is provided by the bearing plate, the rectilinear travel limit and the point travel limit. The position of the two holes is constrained by these limiting surfaces.



**Fig. 22.27** Concept of a datum system.

## Common datums

Fig. 22.32 illustrates two datum features of equal status used to establish a single datum axis. The reference letters, separated by a hyphen, are placed in the third compartment of the tolerance frame.

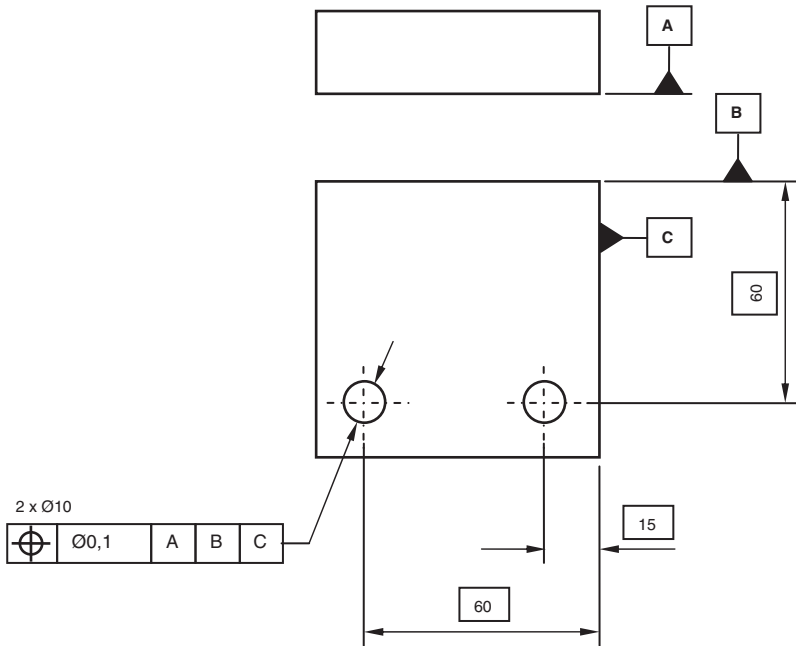
Fig. 22.33 shows an application where a geometrical tolerance is related to two separate datum surfaces indicated in order of priority.

If a positional tolerance is required as shown in Fig. 22.34 and no particular datum is specified, then the individual feature to which the geometrical-tolerance frame is connected is chosen as the datum.

Fig. 22.35 illustrates a further positional-tolerance application where the geometrical requirement is related to another feature indicated as the datum. In the given

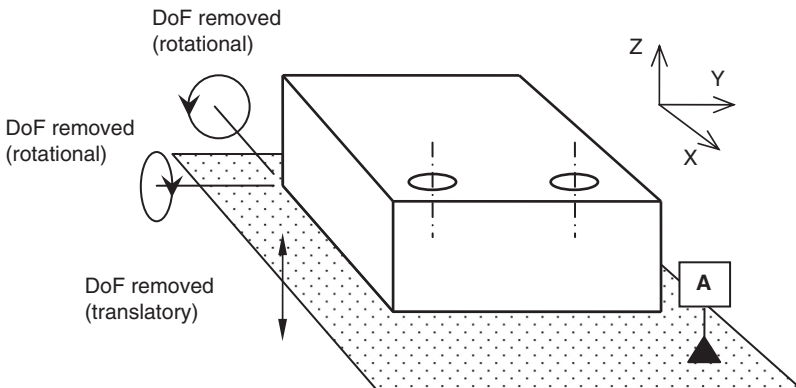
**Specification**

The two holes are positioned in relation to the datum system.



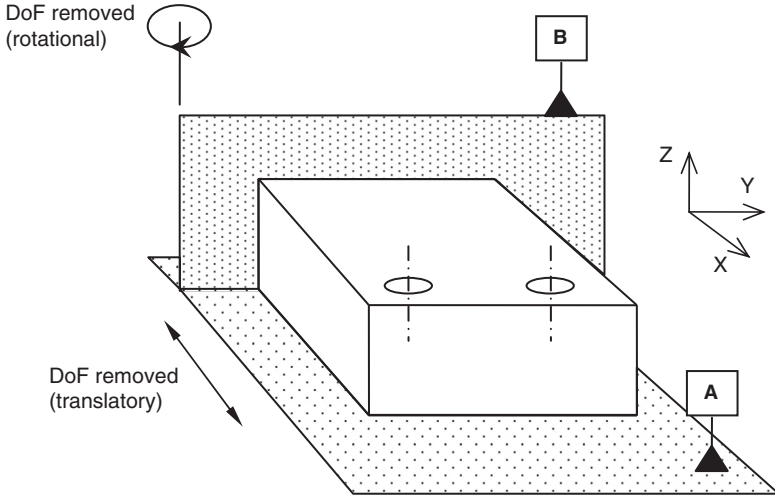
**Fig. 22.28** Specification of a datum system.

**Interpretation – Primary datum ‘A’**  
Tangent plane on the physical surface  
(3 degrees of freedom removed)



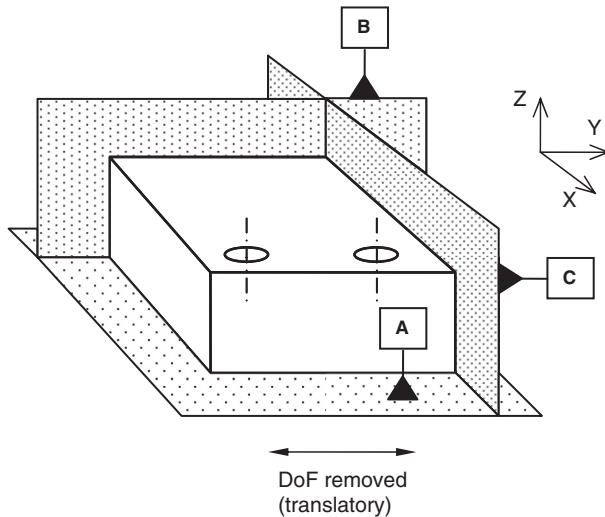
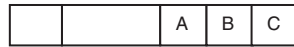
**Fig. 22.29** Interpretation of the primary datum A.

**Interpretation – Secondary datum ‘B’**  
 Plane tangent to the physical surface and perpendicular to ‘A’  
 (2 degrees of freedom removed)



**Fig. 22.30** Interpretation of secondary datum B.

**Interpretation – Tertiary datum ‘C’**  
 Plane tangent to the physical surface and perpendicular to ‘A’ and ‘B’  
 (1 degree of freedom removed)



**Fig. 22.31** Interpretation of tertiary datum C.

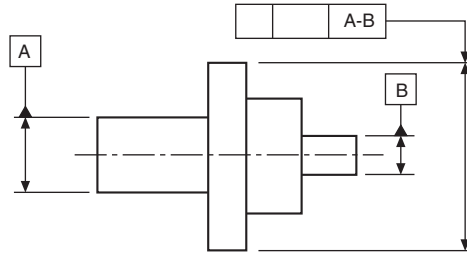


Fig. 22.32 Common datum A-B.

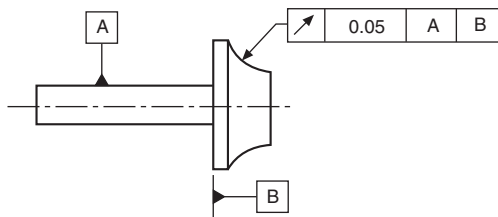


Fig. 22.33 Tolerance applied to two datum surfaces.

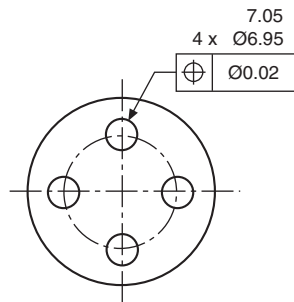


Fig. 22.34 Tolerance with no datum specified.

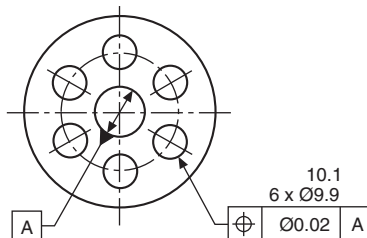


Fig. 22.35 Tolerance applied to features with a different feature indicated as a datum.

example, this implies that the pitch circle and the datum circle must be coaxial, i.e. they have common axes.

## Datum targets

Surfaces produced by forging casting or sheet metal may be subject to bowing, warping or twisting, and not necessarily be flat. It is therefore impractical to designate an entire surface as a functional datum because accurate and repeatable measurements cannot be made from the entire surface.

In order to define a practical datum plane, selected points or areas are indicated on the drawing. Manufacturing processes and inspection utilizes these combined points or areas as datums.

### Datum target symbols

The symbol for a datum target is a circle divided by a horizontal line (see Fig. 22.36). The lower part identifies the datum target. The upper area may be used only for information relating to datum target.



Fig. 22.36 Datum target symbols.

### Indication of datum targets

If the datum target is:

- (a) a point, it is indicated by a cross ..... X.
- (b) a line, it is indicated by two crosses connected by a thin line ..... X  
— — — — X.
- (c) an area, it is indicated by a hatched area surrounded by a thin double dashed chain.

All symbols appear on the drawing view which most clearly shows the relevant surface (see Fig. 22.37).

### Practical application of datum targets

Interpretation — in Fig. 22.38, it is understood that:

- (a) Datum targets A1, A2, and A3 establish Datum A.
- (b) Datum targets B1 and B2 establish Datum B.
- (c) Datum target C1 establishes Datum C.

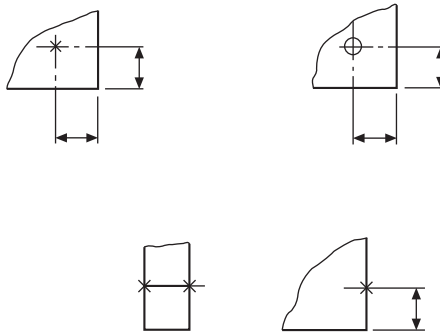


Fig. 22.37 Indicating datum targets.

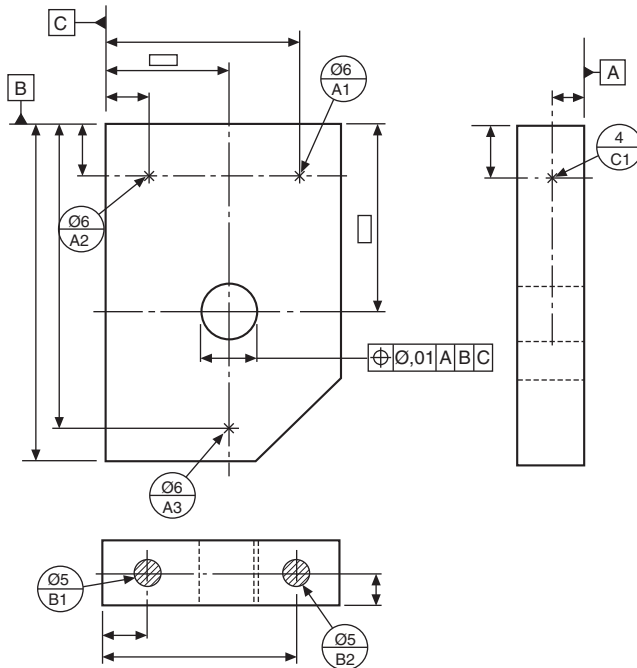


Fig. 22.38 Application of datum targets.

## Dimensioning and tolerancing non-rigid parts

The basic consideration is that distortion of a non-rigid part must not exceed that which permits the part to be brought within the specified tolerances for positioning, at assembly and verification. (For example, by applying pressure or forces not exceeding those which may be expected under normal assembly conditions.)

## Definitions

- (a) A non-rigid part relates to the condition of that part which deforms in its free state to an extent beyond the dimensional and geometrical tolerances on the drawing.
- (b) Free-state relates to the condition of a part when subjected only to the force of gravity.
- (c) The symbol used is  $\textcircled{F}$ .

Fig. 22.39 shows a typical application of a buffer detail drawing. In its restrained condition, Datums A and B position the buffer.

Interpretation — the geometrical tolerance followed by symbol is maintained in its free state. Other geometrical tolerances apply in its assembled situation.

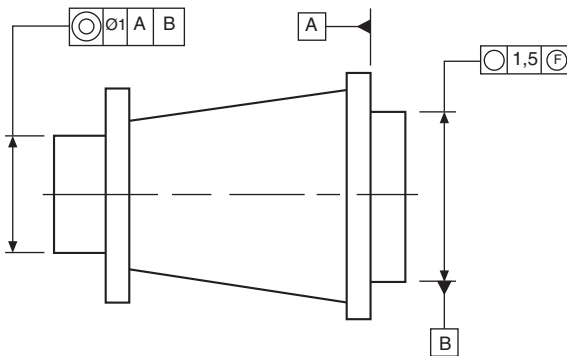


Fig. 22.39 Detail of a part in a restrained condition.

# Application of geometrical tolerances

In this chapter, examples are given of the application of tolerances to each of the characteristics on engineering drawings by providing a typical specification for the product and the appropriate note which must be added to the drawing. In every example, the tolerance values given are only typical figures: the product designer would normally be responsible for the selection of tolerance values for individual cases.

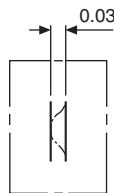
## Straightness

A straight line is the shortest distance between two points. A straightness tolerance controls:

1. the straightness of a line on a surface;
2. the straightness of a line in a single plane;
3. the straightness of an axis.

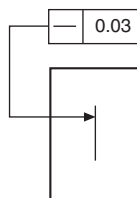
### Case 1

#### *Product requirement*

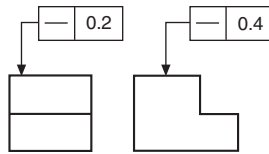


The specified line shown on the surface must lie between two parallel straight lines 0.03 apart.

#### *Drawing instruction*



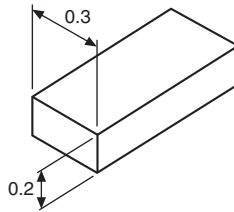
A typical application for this type of tolerance could be a graduation line on an engraved scale.



In the application shown in the above diagram, tolerances are given controlling the straightness of two lines at right angles to one another. In the left-hand view the straightness control is 0.2, and in the right-hand view 0.4. As in the previous example, the position of the graduation marks would be required to be detailed on a plan view.

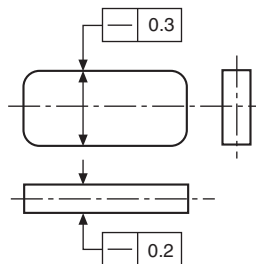
## Case 2

### *Product requirement*



The axis of the whole part must lie in a boxed zone of  $0.3 \times 0.2$  over its length.

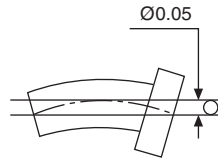
### *Drawing instruction*



As indicated, the straightness of the axis is controlled by the dimensions of the box, and could be applied to a long rectangular key.

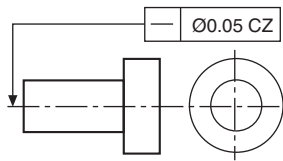
### Case 3

#### Product requirement



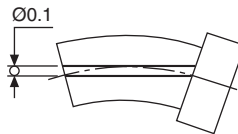
The axis of the whole part must lie within the cylindrical-tolerance zone of 0.05.

#### Drawing instruction



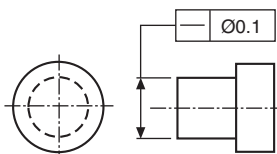
### Case 4

#### Product requirement



The geometrical tolerance may be required to control only part of the component. In this example the axis of the dimensioned portion of the feature must lie within the cylindrical-tolerance zone of 0.1 diameter.

#### Drawing instruction



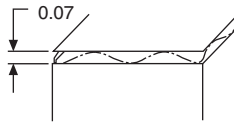
## Flatness

Flatness tolerances control the divergence or departure of a surface from a true plane.

The tolerance of flatness is the specified zone between two parallel planes. It does not control the squareness or parallelism of the surface in relation to other features, and it can be called for independently of any size tolerance.

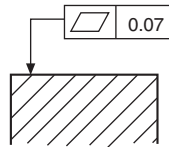
### Case 1

#### *Product requirement*



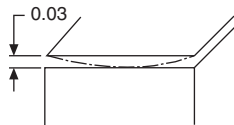
The surface must be contained between two parallel planes 0.07 apart.

#### *Drawing instruction*



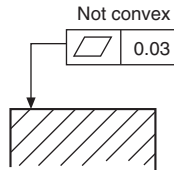
### Case 2

#### *Product requirement*



The surface must be contained between two parallel planes 0.03 apart, but must not be convex.

## Drawing instruction



Note that these instructions could be arranged to avoid a concave condition.

## Circularity (roundness)

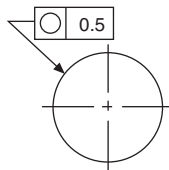
Circularity is a condition where any point of a feature's continuous curved surface is equidistant from its center, which lies in the same plane.

The tolerance of circularity controls the divergence of the feature, and the annular space between the two co-planar concentric circles defines the tolerance zone, the magnitude being the algebraic difference of the radii of the circles.

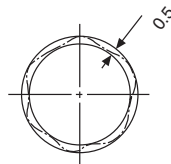
### Case 1

#### Product requirement

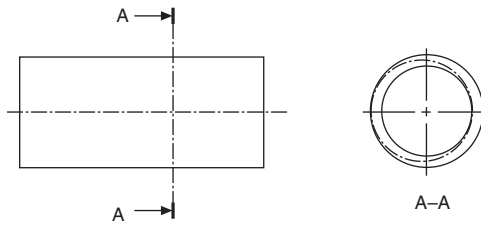
The circumference of the bar must lie between two co-planar concentric circles 0.5 apart.



#### Drawing instruction



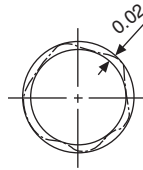
Note that, at any particular section, a circle may not be concentric with its axis but may still satisfy a circularity tolerance. The following diagram shows a typical condition.



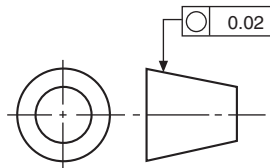
### Case 2

#### *Product requirement*

The circumference at any cross-section must lie between two co-planar concentric circles 0.02 apart.



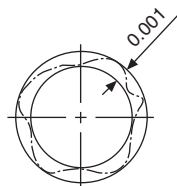
#### *Drawing instruction*



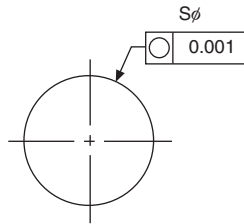
### Case 3

#### *Product requirement*

The periphery of any section of maximum diameter of the sphere must lie between concentric circles a radial distance 0.001 apart in the plane of the section.



## Drawing instruction



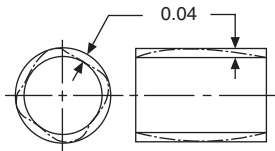
## Cylindricity

The combination of parallelism, circularity and straightness defines cylindricity when applied to the surface of a cylinder, and is controlled by a tolerance of cylindricity. The tolerance zone is the annular space between two coaxial cylinders, the radial difference being the tolerance value to be specified.

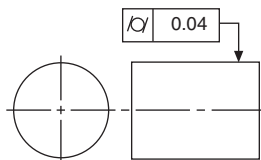
It should be mentioned that, due to difficulties in checking the combined effects of parallelism, circularity and straightness, it is recommended that each of these characteristics is toleranced and inspected separately.

## Product requirement

The whole curved surface of the feature must lie between an annular tolerance zone 0.04 wide formed by two cylindrical surfaces coaxial with each other.



## Drawing instruction



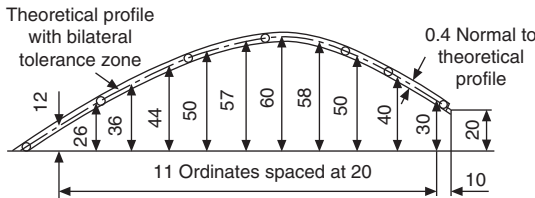
## Profile tolerance of a line

Profile tolerance of a line is used to control the ideal contour of a feature. The contour is defined by theoretically exact boxed dimensions and must be accompanied by a relative tolerance. This tolerance zone, unless otherwise stated, is taken to be equally disposed about the true form, and the tolerance value is equal to the diameter of circles whose centers lie on the true form. If it is required to call for the tolerance zone to be positioned on one side of the true form (i.e. unilaterally), the circumferences of the tolerance-zone circles must touch the theoretical contour of the profile.

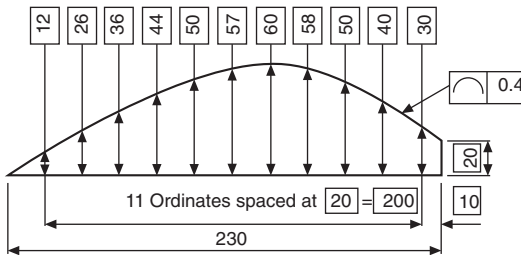
### Case 1

#### Product requirement

The profile is required to be contained within the bilateral tolerance zone.



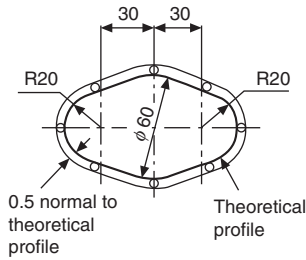
#### Drawing instruction



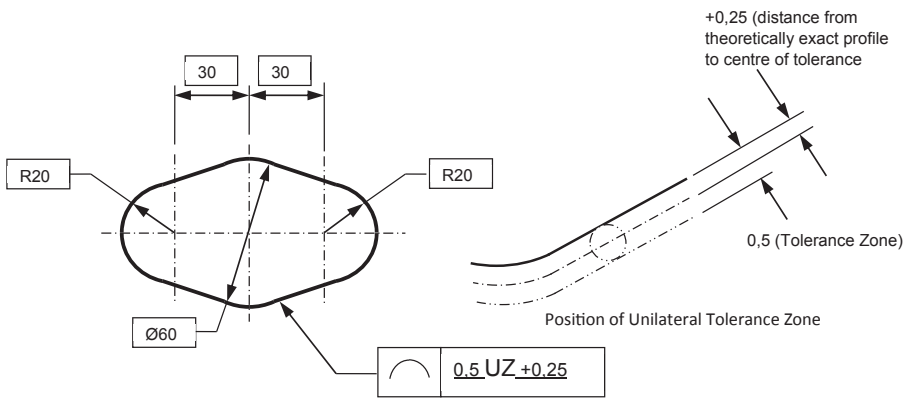
### Case 2

#### Product requirement

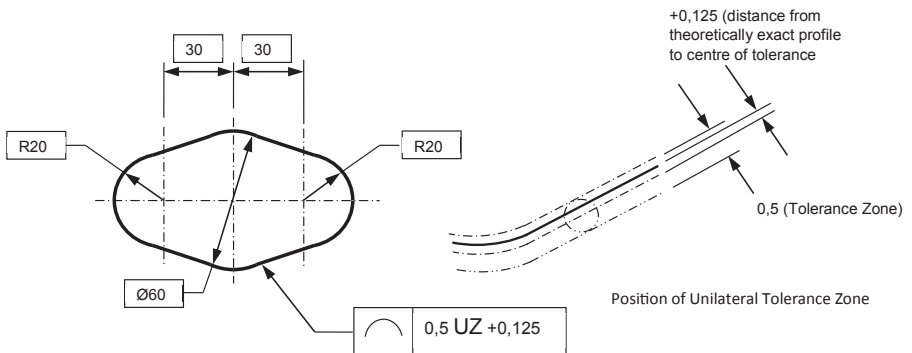
The profile is required to be contained within a unilateral tolerance zone of 0.5 mm outside of the theoretical profile (see below for graphical description) or unequal tolerance zone of 0.5 mm positioned 0.125 mm outside of the theoretical profile.



*Drawing instruction*



Unilateral Tolerance Zone Drawing Indication



Unequal Tolerance Zone Drawing Indication

Prompted by the increase in 3D specification and the publication of 'BS ISO 16792 – Digital product definition data practices', the new method as illustrated above has been

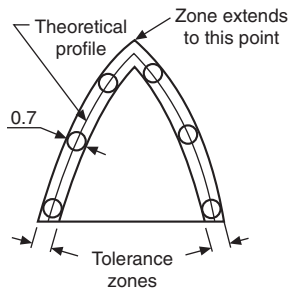
introduced to eliminate the need to define the position of the tolerance zone by using supplemental geometry. No graphical method of specifying unilateral or unequal tolerance zones existed prior to this new method. In this case a modifier UZ is placed in the tolerance frame after the tolerance value to signify a unilateral or unequal condition. A value as to the location of the center of the tolerance zone in relation to the theoretical profile is then placed after the UZ modifier. A plus (+) value indicates the tolerance zone is positioned outwards from the theoretical profile and a minus (−) value indicates the tolerance zone is positioned inwards from the theoretical profile. As the case illustrated is a unilateral tolerance, the modifying value is half of the total tolerance.

This method can be used both for the profile of a line and the profile of a surface.

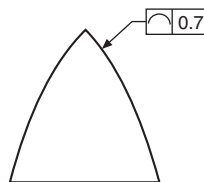
The figure below shows an example where the tolerated profile of a feature has a sharp corner. The inner tolerance zone is considered to end at the intersection of the inner boundary lines, and the outer tolerance zone is considered to extend to the outer boundary-line intersections. Sharp corners such as these could allow considerable rounding; if this is desirable, then the design requirement must be clearly defined on the drawing by specifying a radius or adding a general note such as 'ALL CORNERS 0.5 MAX'. It should be noted that such radii apply regardless of the profile tolerance.

In the example given, the product is required to have a sharp corner.

### Product requirement



### Drawing instruction

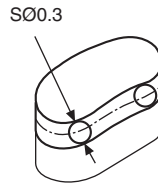


## Profile tolerance of a surface

Profile tolerance of a surface is used to control the ideal form of a surface, which is defined by theoretically exact boxed dimensions and must be accompanied by a relative-tolerance zone. The profile-tolerance zone, unless otherwise stated, is taken to be bilateral and equally disposed about its true-form surface. The tolerance value is equal to the diameter of spheres whose center lines lie on the true form of the surface. The zone is formed by surfaces which touch the circumferences of the spheres on either side of the ideal form.

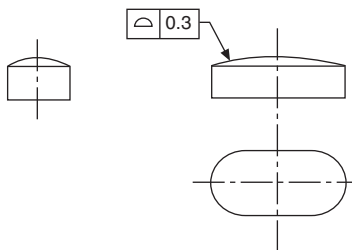
If it is required to call for a unilateral tolerance zone, then the circumferences of the tolerance zone spheres must touch the theoretical contour of the surface.

### Product requirement



The tolerance zone is to be contained by upper and lower surfaces which touch the circumference of spheres of 0.3 diameter whose centers lie on the theoretical form of the surface.

### Drawing instruction



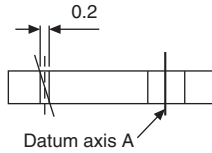
## Parallelism

Two parallel lines or surfaces are always separated by a uniform distance. Lines or surfaces may be required to be parallel with datum planes or axes. Tolerance zones may be the space between two parallel lines or surfaces, or the space contained within a cylinder positioned parallel to its datum. The magnitude of the tolerance value is the distance between the parallel lines or surfaces, or the cylinder diameter.

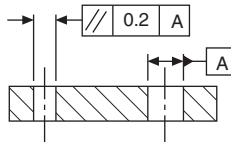
## Case 1

### Product requirement

The axis of the hole on the left-hand side must be contained between two straight lines 0.2 apart, parallel to the datum axis A and lying in the same vertical plane.



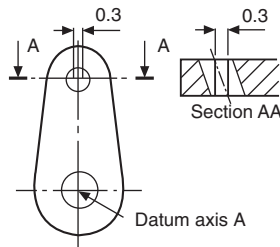
### Drawing instruction



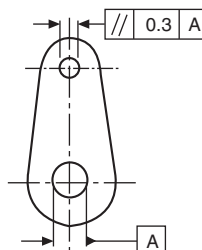
## Case 2

### Product requirement

The axis of the upper hole must be contained between two straight lines 0.3 apart which are parallel to and symmetrically disposed about the datum axis A and lie in the same horizontal plane.



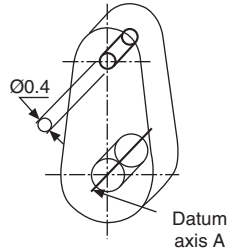
### Drawing instruction



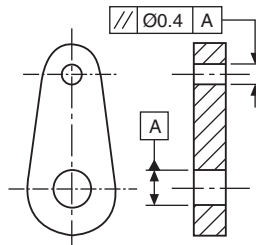
### Case 3

#### Product requirement

The upper hole axis must be contained in a cylindrical zone 0.4 diameter, with its axis parallel to the datum axis A.



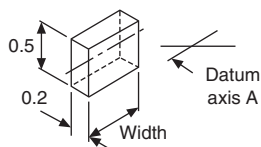
#### Drawing instruction



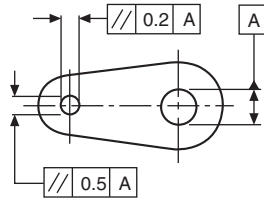
### Case 4

#### Product requirement

The axis of the hole on the left-hand side must be contained in a tolerance box  $0.5 \times 0.2 \times \text{width}$ , as shown, with its sides parallel to the datum axis A and in the same horizontal plane.



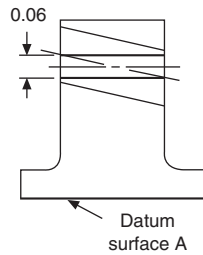
### Drawing instruction



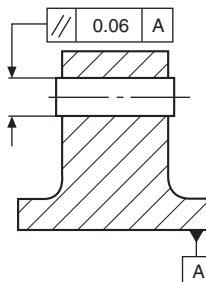
### Case 5

#### Product requirement

The axis of the hole must be contained between two planes 0.06 apart parallel to the datum surface A.



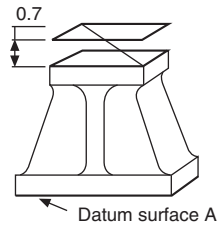
### Drawing instruction



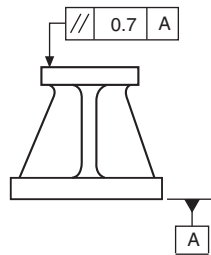
### Case 6

#### Product requirement

The top surface of the component must be contained between two planes 0.7 apart and parallel to the datum surface A.



### Drawing instruction



## Perpendicularity (squareness)

Perpendicularity is the condition when a line, plane or surface is at right angles to a datum feature.

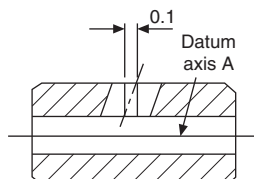
The tolerance zone is the space between two parallel lines or surfaces; it can also be the space contained within a cylinder. All tolerance zones are perpendicular to the datum feature.

The magnitude of the tolerance value is the specified distance between these parallel lines or surfaces, or the diameter of the cylinder.

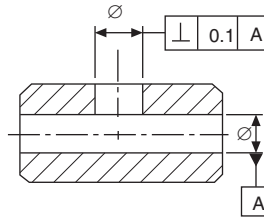
### Case 1

#### Product requirement

The axis of the vertical hole must be contained between two planes 0.1 apart which are perpendicular to the datum axis.



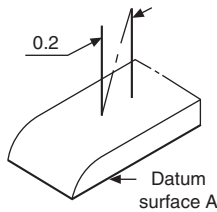
## Drawing instruction



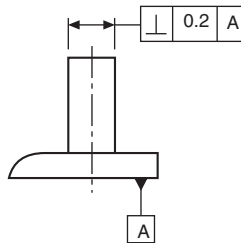
## Case 2

### Product requirement

The axis of the upright must be contained between two straight lines 0.2 apart which are perpendicular to the datum. Squareness is controlled here in one plane only.



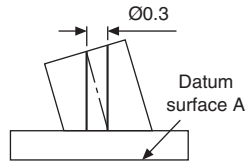
## Drawing instruction



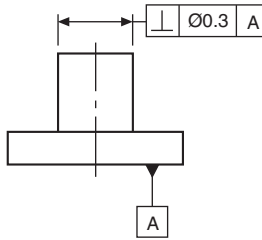
## Case 3

### Product requirement

The axis of the column must be contained in a cylindrical tolerance zone 0.3 diameter, the axis of which is perpendicular to the datum surface A. Squareness is controlled in more than one plane by this method.



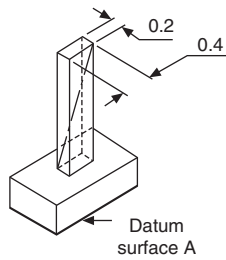
*Drawing instruction*



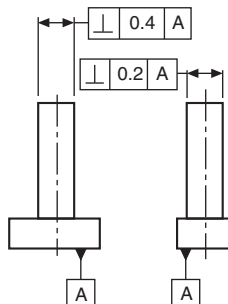
**Case 4**

*Product requirement*

The axis of the column must be contained in a tolerance zone box  $0.2 \times 0.4$  which is perpendicular to the datum surface A.

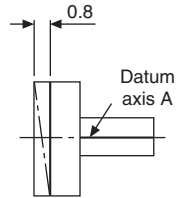


*Drawing instruction*



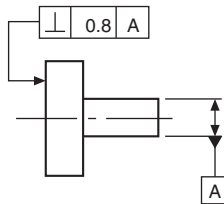
## Case 5

### *Product requirement*



The left-hand end face of the part must be contained between two parallel planes 0.8 apart and perpendicular to the datum axis A.

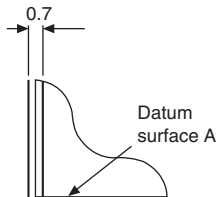
### *Drawing instruction*



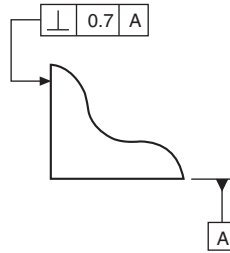
## Case 6

### *Product requirement*

The left-hand surface must be contained between two parallel planes 0.7 apart and perpendicular to the datum surface A.



## Drawing instruction



## Angularity

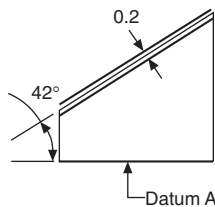
Angularity defines a condition between two related planes, surfaces or lines which are not perpendicular or parallel to one another. Angularity tolerances control this relationship.

The specified angle is a basic dimension, and is defined by a theoretically exact boxed dimension and must be accompanied by a tolerance zone. This zone is the area between two parallel lines inclined at the specified angle to the datum line, plane or axis. The tolerance zone may also be the space within a cylinder, the tolerance value being equal to the cylinder diameter. In this case, symbol  $\varnothing$  precedes the tolerance value in the tolerance frame.

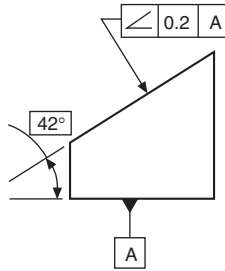
### Case 1

#### Product requirement

The inclined surface must be contained within two parallel planes 0.2 apart which are at an angle of  $42^\circ$  to the datum surface.

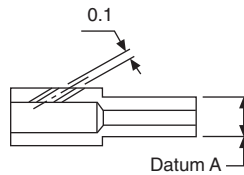


### Drawing instruction



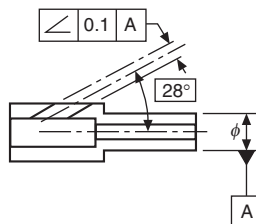
### Case 2

#### Product requirement



The axis of the hole must be contained within two parallel straight lines 0.1 apart inclined at  $28^\circ$  to the datum axis.

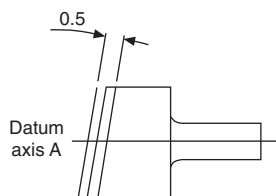
#### Drawing instruction



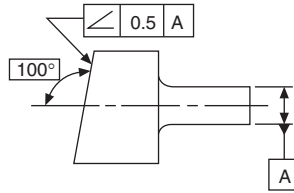
### Case 3

#### Product requirement

The inclined surface must be contained within two parallel planes 0.5 apart which are inclined at  $100^\circ$  to the datum axis.



## Drawing instruction



## Circular run-out

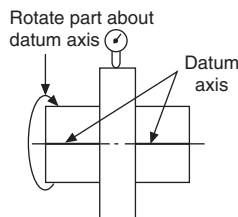
Circular run-out is a unique geometrical tolerance. It can be a composite form control relating two or more characteristics, and it requires a practical test where the part is rotated through  $360^\circ$  about its own axis.

The results of this test may include errors of other characteristics such as circularity, concentricity, perpendicularity, or flatness, but the test cannot discriminate between them. It should therefore not be called for where the design function of the part necessitates that the other characteristics are to be controlled separately. The sum of any of these errors will be contained within the specified circular run-out tolerance value. The tolerance value is equal to the full indicator movement of a fixed point measured during one revolution of the component about its axis, without axial movement. Circular run-out is measured in the direction specified by the arrow at the end of the leader line which points to the toleranced feature. It must always be measured regardless of feature size, and it is convenient for practical purposes to establish the datum as the diameter(s) from which measurement is to be made, if true centers have not been utilized in manufacturing the part.

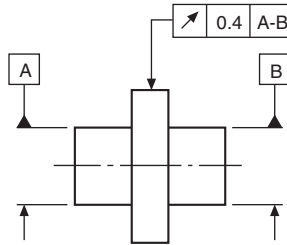
### Case 1

#### Product requirement

The circular radial run-out must not exceed 0.4 at any point along the cylinder, measured perpendicular to the datum axis without axial movement.



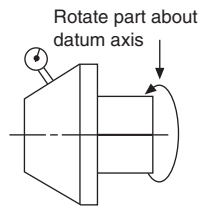
### Drawing instruction



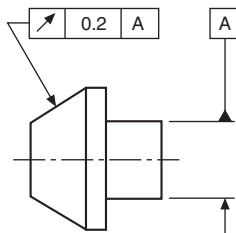
### Case 2

#### Product requirement

Circular run-out must not exceed 0.2 measured at any point normal to the surface, without axial movement.



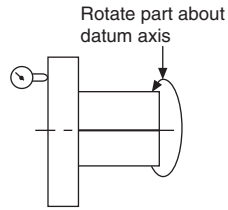
### Drawing instruction



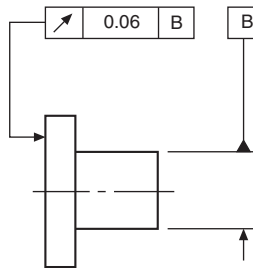
### Case 3

#### Product requirement

At any radius, the circular run-out must not exceed 0.06 measured parallel to the datum axis.



### Drawing instruction



## Case 4

### Product requirement

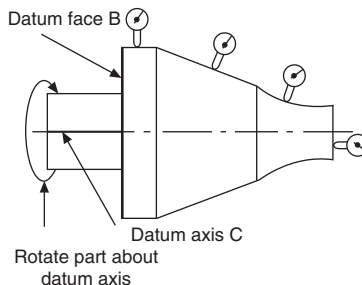
The component is required to be rotated about datum axis C, with datum face B set to ensure no axial movement.

The circular radial run-out on the cylindrical portion must not exceed 0.05 at any point measured perpendicular to the datum axis.

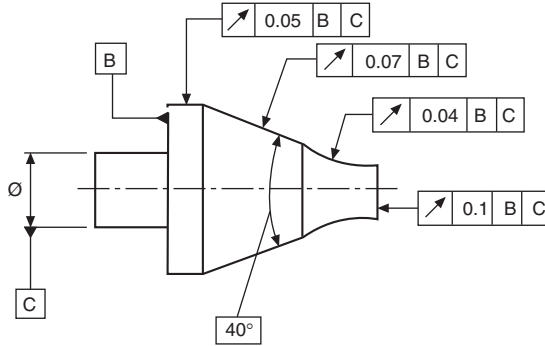
The circular run-out on the tapered portion must not exceed 0.07 at any point measured normal to its surface.

The circular run-out on the curved portion must not exceed 0.04 at any point measured normal to its surface.

The axial run-out of the end face must not exceed 0.1 at any point measured parallel to the datum axis of rotation.



**Drawing instruction**



*Circular run-out* provides composite control of circular elements of a surface.

*Total run-out* provides composite control of all surface elements. The complete surface is measured, not single points, as in circular run-out.

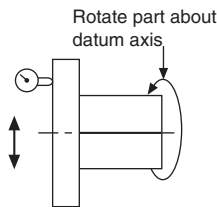
Total run-out controls cumulative variations of perpendicularity which can detect wobble, and also flatness, which can detect concavity and convexity.

**Total run-out**

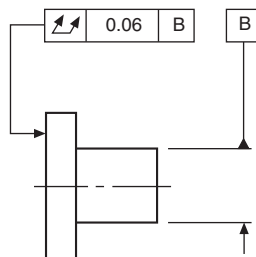
**Case 1**

*Product requirement*

The total run-out must not exceed 0.06 at any point measured across the entire surface parallel to the datum axis.



**Drawing instruction**



*Note:* The symbol means that the measuring instrument is guided across a theoretically exact surface true to the datum axis.

## Position

A positional tolerance controls the location of one feature from another feature or datum.

The tolerance zone can be the space between two parallel lines or planes, a circle, or a cylinder. The zone defines the permissible deviation of a specified feature from a theoretically exact position.

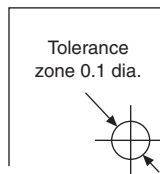
The tolerance value is the distance between the parallel lines or planes, or the diameters of the circle or cylinder.

The theoretically exact position also incorporates squareness and parallelism of the tolerance zones with the plane of the drawing.

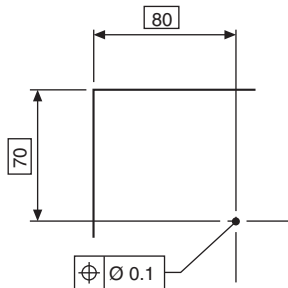
### Case 1

#### Product requirement

The point must be contained within a circle of 0.1 diameter in the plane of the surface. The circle has its center at the intersection of the two theoretically exact dimensions. If the point were to be located by three dimensions, the tolerance zone would be a sphere.



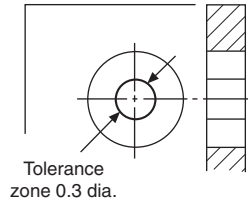
#### Drawing instruction



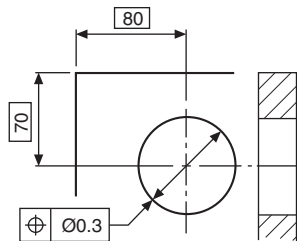
## Case 2

### Product requirement

The axis of the hole must be contained in a cylindrical-tolerance zone of 0.3 diameter with its axis coincident with the theoretically exact position of the hole axis.



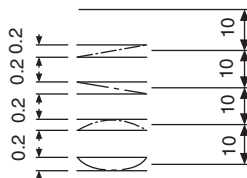
### Drawing instruction



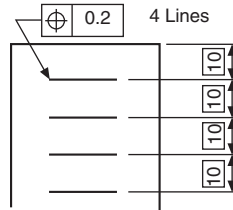
## Case 3

### Product requirement

Each line must be contained between two parallel straight lines on the surface, 0.2 apart, which are symmetrical with the theoretically exact positions of the required lines.



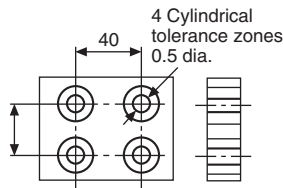
*Drawing instruction*



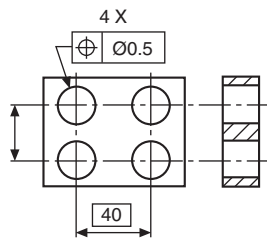
**Case 4**

*Product requirement*

The axes of each of the four holes must be contained in a cylindrical-tolerance zone of 0.5 diameter, with its own axis coincident with the theoretically exact position of each hole.



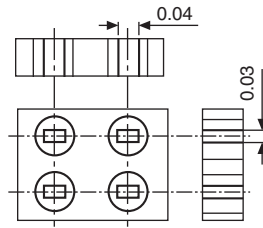
*Drawing instruction*



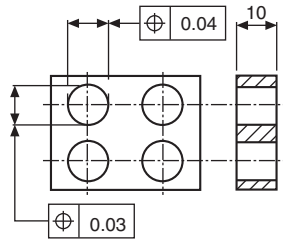
**Case 5**

*Product requirement*

The axes of each of the four holes must be contained in a boxed zone of  $0.04 \times 0.03 \times 10$ , symmetrically disposed about the theoretically exact position of each hole axis.



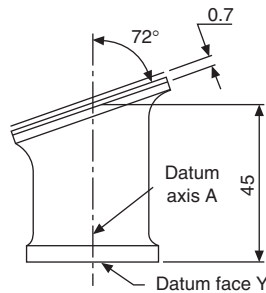
### Drawing instruction



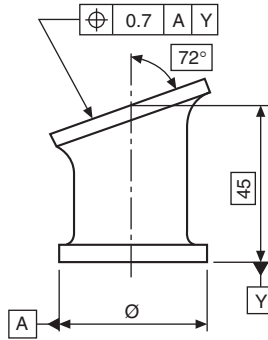
### Case 6

#### Product requirement

The angled surface must be contained between two parallel planes 0.7 apart, which are symmetrically disposed about the theoretically exact position of the surface relative to datum axis  $X$  and datum face  $Y$ .



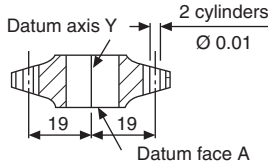
*Drawing instruction*



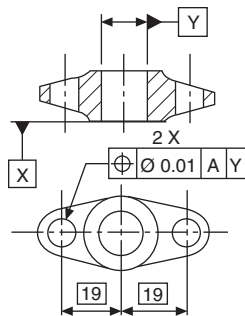
**Case 7**

*Product requirement*

The axes of the two holes must be contained in cylindrical tolerance zones of 0.01 diameter, with their own axes coincident with the theoretically exact hole positions related to datum face X and the datum centre-line axis Y.



*Drawing instruction*



## Concentricity and coaxiality

Two circles are said to be concentric when their centers are coincident.

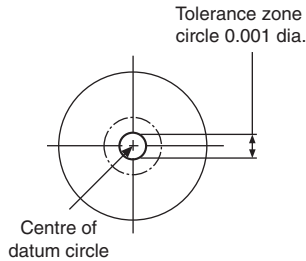
Two cylinders are said to be coaxial when their axes are coincident.

The deviation from the true center or datum axis is controlled by the magnitude of the tolerance zone.

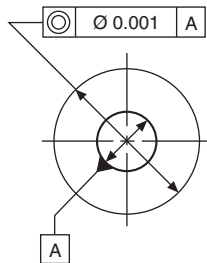
### Case 1 (concentricity)

#### Product requirement

To contain the center of the large circle within a circular-tolerance zone of 0.001 diameter which has its center coincident with the datum-circle center.



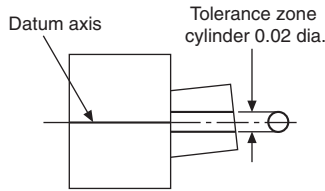
#### Drawing instruction



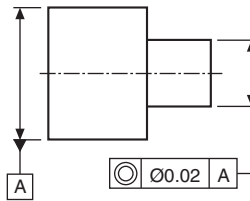
### Case 2 (coaxiality)

#### Product requirement

To contain the axis of the right-hand cylinder within a cylindrical-tolerance zone which is coaxial with the axis of the datum cylinder.



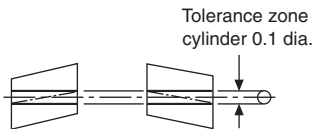
*Drawing instruction*



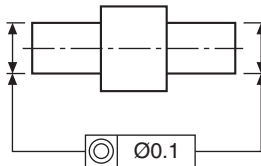
**Case 3 (coaxiality)**

*Product requirement*

To contain the axes of both the left- and right-hand cylinders within a cylindrical-tolerance zone.



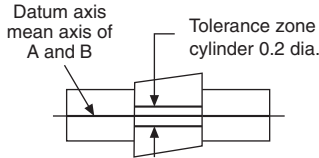
*Drawing instruction*



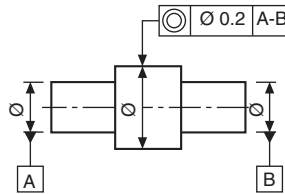
### Case 4 (coaxiality)

#### Product requirement

To contain the axis of the central cylinder within a cylindrical tolerance zone which is coaxial with the mean axes of the left- and right-hand cylinders.



#### Drawing instruction



## Symmetry

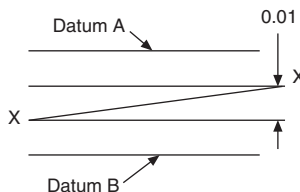
Symmetry involves the division of spacing of features so that they are positioned equally in relation to a datum, which may be a line or plane. The tolerance zone is the space between two parallel lines or planes, parallel to, and positioned symmetrically with the datum. The tolerance magnitude is the distance between these two parallel lines or planes.

Symmetry also implies perpendicularity with the plane of the drawing where depth is involved.

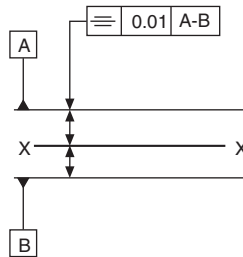
### Case 1

#### Product requirement

The specified line XX must lie in a tolerance zone formed by two parallel straight lines 0.01 apart and disposed symmetrically between datums A and B.



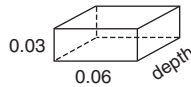
### Drawing instruction



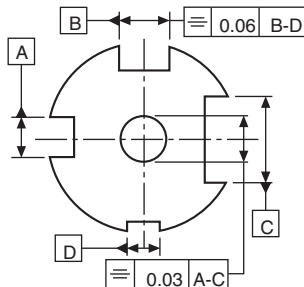
### Case 2

#### Product requirement

The axis of a hole in a plate must lie in a rectangular-box tolerance zone  $0.03 \times 0.06 \times$  depth of the plate, parallel with and symmetrically disposed about the common median planes formed by slots AC and BD.



### Drawing instruction



## Alternative tolerancing method using geometrical tolerancing in place of general tolerancing

Traditionally, non-functional features were often toleranced by general tolerances, either as an instruction in the tolerance box in the drawing frame or as a general

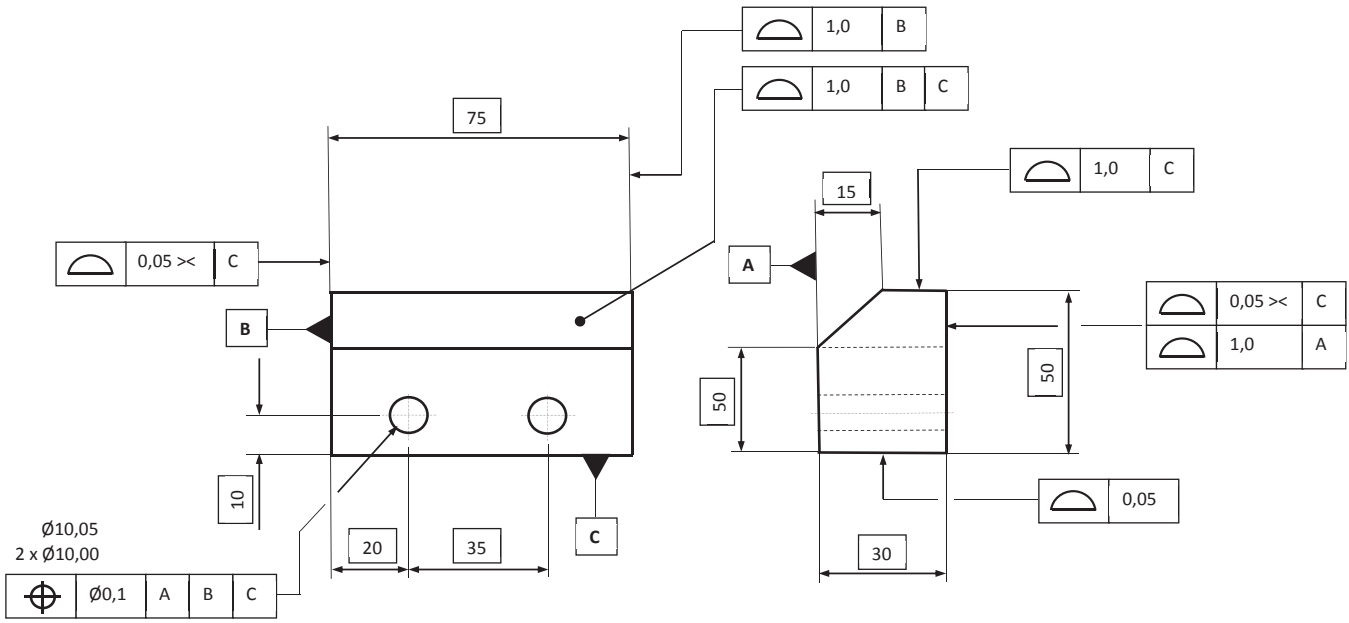
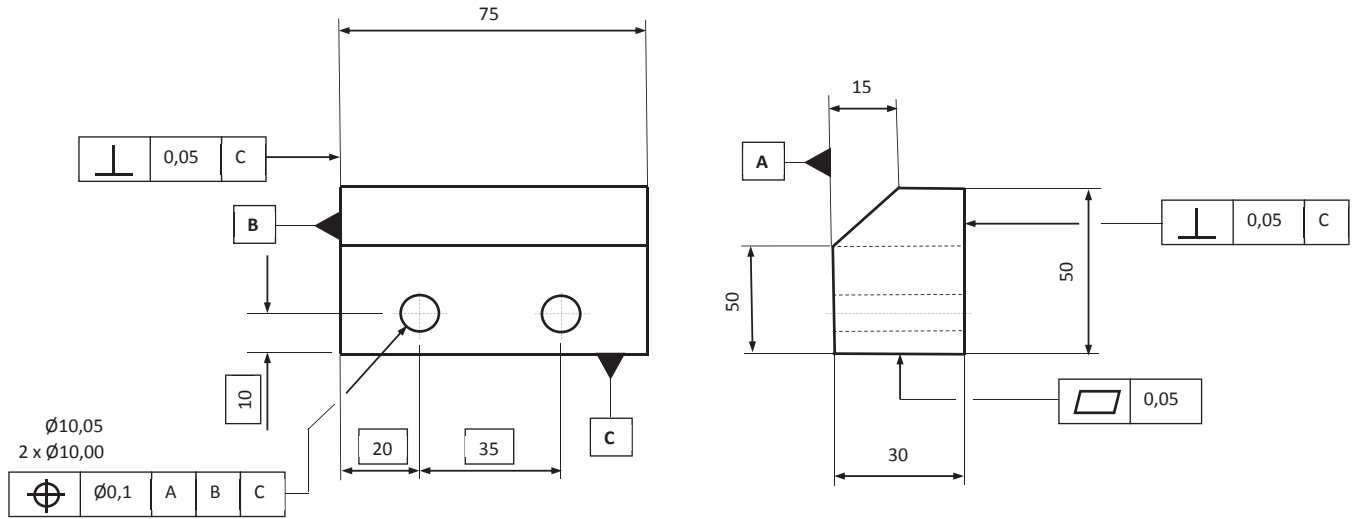


Fig. 23.1 Part using general tolerances and orientation geometrical tolerances.



TOLERANCES  $\pm 0,5$  UNLESS STATED

**Fig. 23.2** Part using TED's and mainly profile of a surface geometrical tolerances.

note on the drawing, Orientation geometrical tolerances are often used to add additional requirements. The use of TEDs and a couple of geometrical tolerances (positional tolerance and profile of a surface) can achieve the same results and cover most other tolerancing requirements. This way of tolerancing suits current computer aided manufacturing and inspection techniques but can also be verified by more traditional methods. See [Figs. 23.1 and 23.2](#) for a comparison between the two methods. Where only the orientation of a surface needs to be controlled the use of the orientation constraint only symbol  $\text{><}$  should be applied (see [Figs. 22.1C and 23.2](#)).

Developing this concept further, assuming there is a master model (at mid material condition/virtual condition) from which the drawing is derived, the indication of TED's can be reduced or removed by making reference on the drawing to the model and specifying that all dimensions are taken directly from the model.

# Maximum material and least material requirements

## Maximum material condition (MMC)

MMC is that condition of a part or feature which contains the maximum amount of material everywhere, e.g. minimum-size hole, or a maximum-size shaft. In certain cases its use allows an increase in the specified tolerance (often termed a bonus tolerance) if it is indicated that the tolerance applies to the feature at its maximum material condition.

The *maximum material requirement* takes into account the mutual dependence of tolerances of size, form, orientation and/or location and permits additional tolerance as the considered feature departs from its maximum material condition.

The free assembly of components depends on the combined effect of the actual finished sizes and the errors of form or position of the parts.

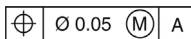
Any errors of form or position between two mating parts have the effect of virtually altering their respective sizes. The tightest condition of assembly between two mating parts occurs when each feature is at the MMC, plus the maximum errors permitted by any required geometrical tolerance.

Assembly clearance is increased if the actual sizes of the mating features are finished away from their MMC, and if any errors of form or position are less than that called for by any geometrical control. Also, if either part is finished away from its MMC, the clearance gained could allow for an increased error of form or position to be accepted. Any increase of tolerance gained this way, provided it is functionally acceptable for the design, is advantageous during the process of manufacture (Fig. 24.1).

The symbol for maximum material requirement is the letter M enclosed by a circle (M).

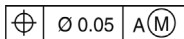
The symbol is positioned in the tolerance frame as follows:

(a)



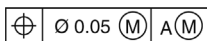
Refers to the tolerance only.

(b)



Refers to the datum only.

(c)



Refers to both tolerance and datum.

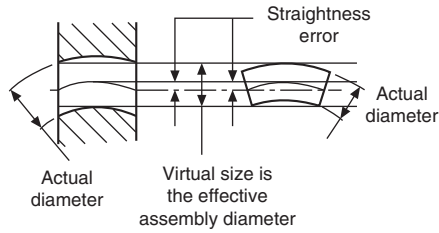


Fig. 24.1 Increased assembly clearance.

## Least material condition (LMC)

LMC is that condition of a part or feature which contains the minimum amount of material, e.g. maximum-size hole or a minimum-size shaft.

Circumstances do arise where, for example, a designer would require to limit the minimum wall thickness between a hole and the side of a component. In such a case, we need to control the least material condition where a part contains the minimum amount of material.

The appropriate tolerance would then be quoted, followed by the letter L inside a circle (L).

Generally such examples are very few. The applications which follow cover the more widely found requirements of MMC.

## Maximum material requirement related to geometrical form

The limit of size, together with geometrical form or position of a feature, are factors of the maximum material principle, and its application is restricted to those features whose size is specified by toleranced dimensions incorporating an axis or median plane. It can never be applied to a plane, surface, or line on a surface.

The characteristics to which it can be applied are as follows:

- straightness
- parallelism
- squareness
- angularity
- position
- concentricity
- symmetry.

The characteristics to which the maximum material requirement concept cannot be applied are as follows:

- flatness
- roundness

- cylindricity
- profile of a line
- profile of a surface
- run-out.

## Maximum material requirement applied to straightness

Fig. 24.2 shows a typical drawing instruction where limits of size are applied to a pin, and in addition a straightness tolerance of 0.2 is applicable at the maximum material condition.

Fig. 24.3 shows the requirement where the pin is finished at the maximum material condition with the maximum straightness error. The effective assembly diameter will be equal to the sum of the upper limit of size and the straightness tolerance.

The straightness error is contained within a cylindrical tolerance zone of  $\varnothing 0.2$ .

To provide the same assembly diameter of 20.7 as shown in Fig. 24.4 when the pin is finished at its low limit of size of 20.0, it follows that a straightness error of 0.7 could be acceptable. This increase may in some cases have no serious effect on the function of the component, and can be permitted.

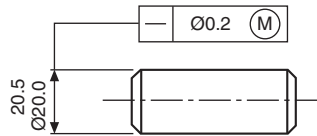


Fig. 24.2 Pin with maximum material condition applied to straightness.

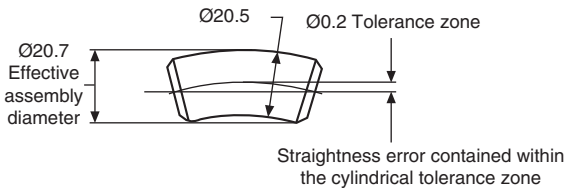


Fig. 24.3 Pin at maximum material condition with maximum straightness error.

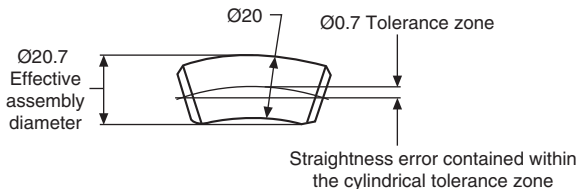


Fig. 24.4 Pin at minimum size.

## Maximum material requirement applied to squareness

Fig. 24.5 shows a typical drawing instruction where limits of size are applied to a pin, and in addition a squareness tolerance of 0.3 is applicable at the maximum material condition.

Fig. 24.6 shows the requirement where the pin is finished at the maximum material condition with the maximum squareness error of 0.3. The effective assembly diameter will be the sum of the upper limit of size and the squareness error. The squareness error will be contained within a cylindrical tolerance zone of  $\varnothing 0.3$ .

To provide the same assembly diameter of 30.9, as shown in Fig. 24.7, when the pin is finished at its low limit of size of 30.0, it follows that the squareness error could increase from 0.3 to 0.9. This permitted increase should be checked for acceptability.

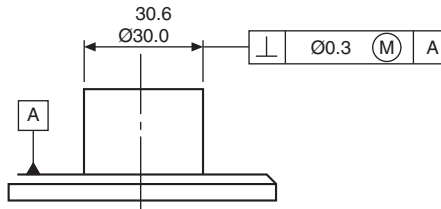


Fig. 24.5 Maximum material requirement applied to squareness.

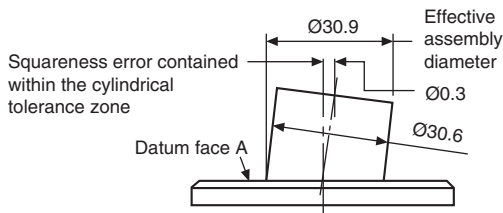


Fig. 24.6 Pin at maximum material condition with maximum squareness tolerance.

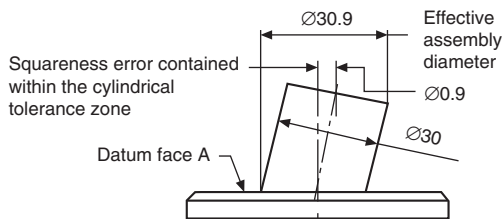


Fig. 24.7 Pin at lowest limit of size permitting an increase in squareness allowance from 0.3 to 0.9 mm.

## Maximum material requirement applied to position

A typical drawing instruction is given in Fig. 24.8, and the following illustrations show the various extreme dimensions which can possibly arise.

Condition A (Fig. 24.9).

Condition B (Fig. 24.10).

Condition C (Fig. 24.11).

Condition D (Fig. 24.12).

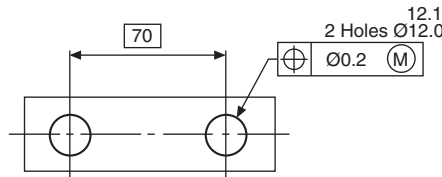


Fig. 24.8 Maximum material requirement applied to position.

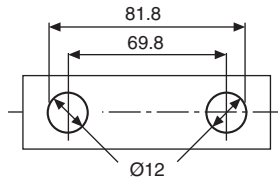


Fig. 24.9 Minimum distance between hole centers and the maximum material condition of holes.

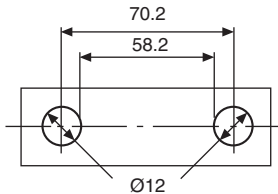


Fig. 24.10 Maximum distance between hole centers and the maximum material condition of holes.

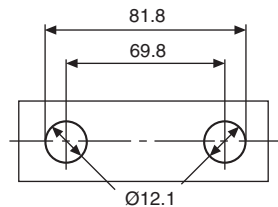
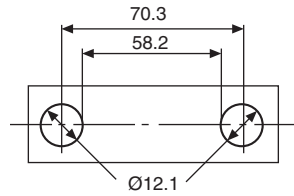


Fig. 24.11 To give the same assembly condition as in A, the minimum distance between hole centers is reduced when the holes are finished away from the maximum material condition.

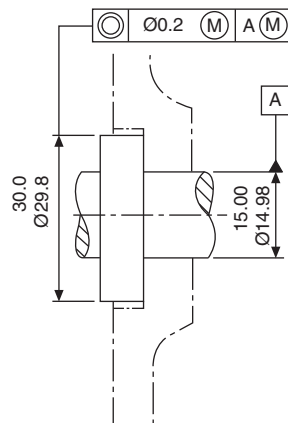


**Fig. 24.12** To give the same assembly condition as in B, the maximum distance between hole centers is increased when the holes are finished away from the maximum material condition.

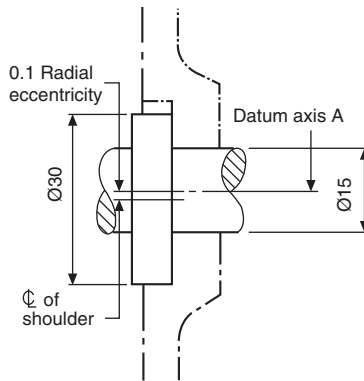
Note that the total tolerance zone is  $0.2 + 0.1 = 0.3$ , and therefore the positional tolerance can be increased where the two holes have a finished size away from the maximum material condition (the difference between the actual size and the maximum material condition can be added to the positional tolerance).

## Maximum material requirement applied to coaxiality

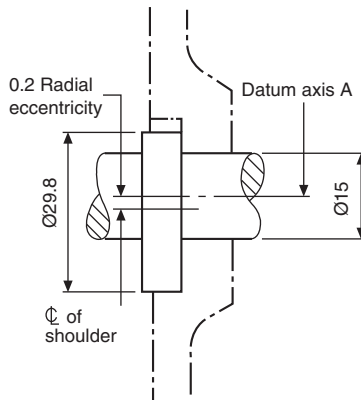
In the previous examples, the geometrical tolerance has been related to a feature at its maximum material condition, and, provided the design function permits, the tolerance has increased when the feature has been finished away from the maximum material condition. Now the geometrical tolerance can also be specified in relation to a datum feature, and Fig. 24.13 shows a typical application and drawing instruction of a shoulder on a shaft. The shoulder is required to be coaxial with the shaft, which acts as the datum. Again, provided the design function permits, further relaxation of the quoted geometrical control can be achieved by applying the maximum material requirement to the datum itself.



**Fig. 24.13** Maximum material requirement applied to coaxiality.



**Fig. 24.14** Shoulder and shaft at maximum material requirement; shoulder at maximum permissible eccentricity to the shaft datum axis X.



**Fig. 24.15** Shoulder at minimum material condition and shaft at maximum material condition. Total coaxiality tolerance = specified coaxiality tolerance + limit of size tolerance of shoulder =  $0.2 + 0.2 = 0.4$  diameter. This gives a maximum eccentricity of 0.2.

Various extreme combinations of size for the shoulder and shaft can arise, and these are given in the drawings below. Note that the increase in coaxiality error which could be permitted in these circumstances is equal to the total amount that the part is finished away from its maximum material condition, i.e. the shoulder tolerance plus the shaft tolerance.

Condition A (Fig. 24.14).

Condition B (Fig. 24.15).

Condition C (Fig. 24.16).

## Maximum material requirement and perfect form

When any errors of geometrical form are required to be contained within the maximum material limits of size, it is assumed that the part will be perfect in form at the upper limit of size.

In applying this principle, two conditions are possible.

Case 1: The value of the geometrical tolerance can progressively increase provided that the assembly diameter does not increase above the maximum material limit of size. Fig. 24.17 shows a shaft and the boxed dimension, and indicates that at maximum material limit of size the shaft is required to be perfectly straight.

Fig. 24.18 shows the shaft manufactured to its lower limit of size, where the permitted error in straightness can be 0.05, since the assembly diameter will be maintained at 16.00. Similarly, a shaft manufactured to, say, 15.97 can have a permitted straightness error of 0.03.

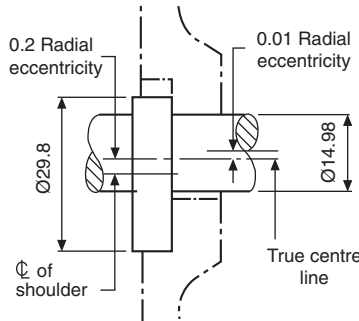


Fig. 24.16 Shows the situation where the smallest size shoulder is associated with the datum shaft at its low limit of size. Here, the total coaxiality tolerance which may be permitted is the sum of the specified coaxiality tolerance + limit of size tolerance for the shoulder + tolerance on the shaft =  $0.2 + 0.2 + 0.02 = 0.42$  diameter.

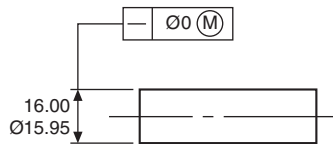


Fig. 24.17 Maximum material requirement and perfect form.

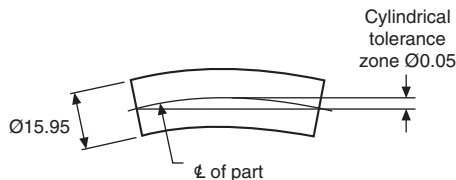


Fig. 24.18 Shaft at minimum size.

Case 2: The geometrical tolerance can also be limited to a certain amount where it would be undesirable for the part to be used in service too much out of line.

Fig. 24.19 shows a shaft, with a tolerance frame indication that at the maximum material limit of size the shaft is required to be perfectly straight. Also, the upper part of the box indicates that a maximum geometrical tolerance error of 0.02 can exist, provided that for assembly purposes the assembly diameter does not exceed 14.00.

Fig. 24.20 shows the largest diameter shaft acceptable, assuming that it has the full geometrical error of 0.02. Note that a shaft finished at 13.99 would be permitted a maximum straightness error of only 0.01 to conform with the drawing specification.

Fig. 24.21 shows the smallest diameter shaft acceptable, and the effect of the full geometrical error of straightness.

## The Application of Maximum Material Requirement and its relationship with perfect form and squareness

A typical drawing instruction is shown in Fig. 24.22.

Condition A (Fig. 24.23).

Condition B (Fig. 24.24).

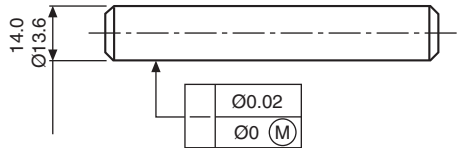


Fig. 24.19 Dual straightness requirements.

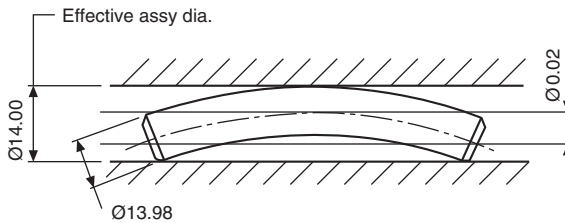


Fig. 24.20 Maximum shaft diameter.

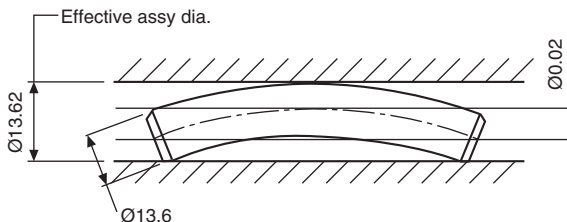
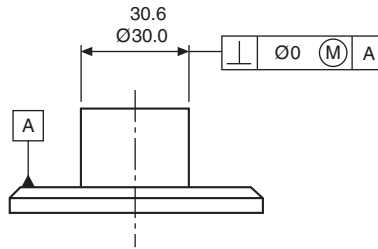
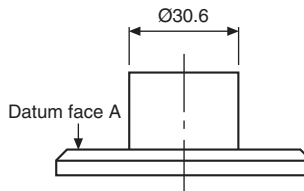


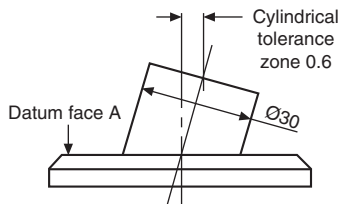
Fig. 24.21 Minimum shaft diameter.



**Fig. 24.22** Maximum material requirement with perfect form applied to squareness.



**Fig. 24.23** Maximum size of feature: zero geometrical tolerance.



**Fig. 24.24** Minimum size of feature; permitted geometrical error = 0.6.

Note that between these extremes the geometrical tolerance will progressively increase; i.e. when the shaft diameter is 30.3, then the cylindrical tolerance error permitted will be 0.3.

## The Application of Maximum Material Requirement and its relationship with perfect form and coaxiality

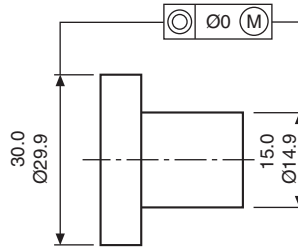
A typical drawing instruction is shown in [Fig. 24.25](#).

Condition A ([Fig. 24.26](#)).

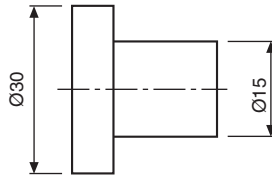
Condition B ([Fig. 24.27](#)).

Condition C ([Fig. 24.28](#)).

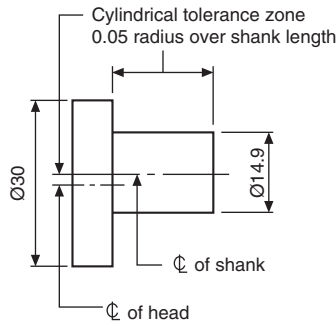
Condition D ([Fig. 24.29](#)).



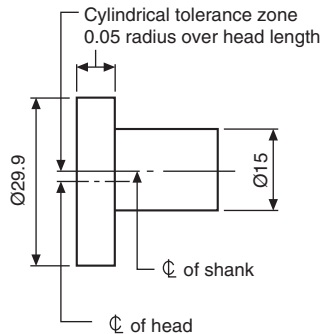
**Fig. 24.25** Maximum material requirement with perfect form applied to coaxiality.



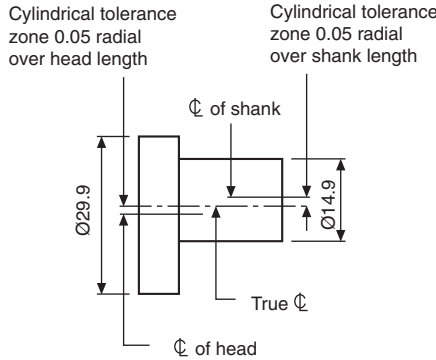
**Fig. 24.26** Head and shank at maximum material requirement. No geometrical error is permitted, and the two parts of the component are coaxial.



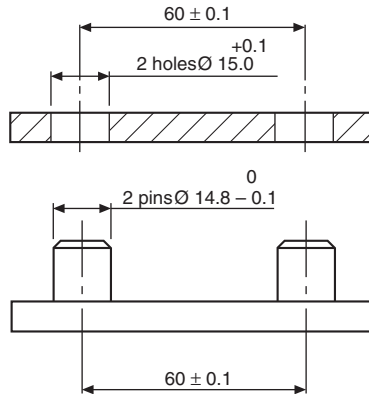
**Fig. 24.27** Head at maximum material requirement; shank at minimum material condition. The permitted geometrical error is equal to the tolerance on the shank size. This gives a tolerance zone of 0.1 diameter.



**Fig. 24.28** Shank at maximum material requirement; head at minimum material condition. The permitted geometrical error is equal to the tolerance on the head size. This gives a tolerance zone of 0.1 diameter.



**Fig. 24.29** Both shank and shaft are finished at their low limits of size; hence the permitted geometrical error will be the sum of the two manufacturing tolerances, namely 0.2 diameter.



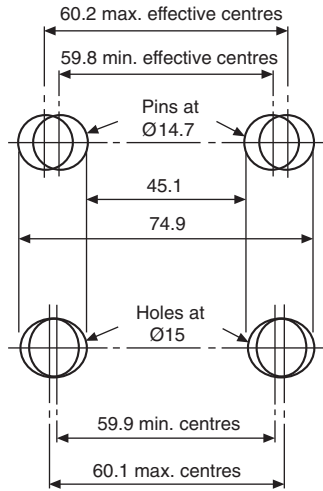
**Fig. 24.30** Male and female components.

## The Application of Maximum Material Requirement to Two Mating Components

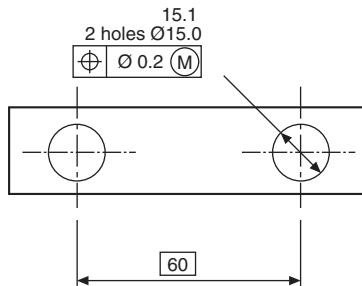
Fig. 24.30 shows a male and a female component dimensioned with a linear tolerance between centers, and which will assemble together under the most adverse conditions allowed by the specified tolerances. The male component has center distance and diameters of pins at maximum condition. The female component has center distance and diameter of holes at minimum condition.

The tolerance diagram in Fig. 24.31, shows that, when the pin diameters are at the least material condition, their center distance may vary between  $74.9$  and  $14.7 = 60.2$ , or  $45.1 + 14.7 = 59.8$ . Now this increase in tolerance can be used to advantage, and can be obtained by applying the maximum material concept to the drawing detail.

Similarly, by applying the same principle to the female component, a corresponding advantage is obtainable. The lower part of Fig. 24.31 shows the female component in



**Fig. 24.31** Pins at least material condition and holes at maximum material condition.



**Fig. 24.32** Holes controlled by positional tolerance.

its maximum material condition. Assembly with the male component will be possible if the dimension over the pins does not exceed 74.9 and the dimension between the pins is no less than 45.1.

Fig. 24.32 shows the method of dimensioning the female component with holes controlled by a positional tolerance, and modified by maximum material requirement. This ensures assembly with the male component, whose pins are manufactured regardless of feature size.

When the maximum requirement is applied to these features, any errors of form or position can be checked by using suitable gauges.

For further details regarding maximum and minimum material requirement refer to BS EN ISO 2692.

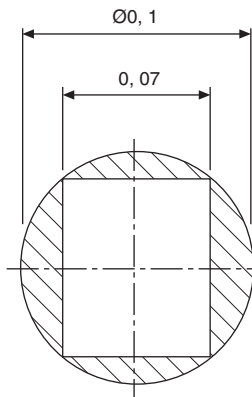
The essential requirement is to be able to define the limits for location of actual features, e.g., axes, points, median surfaces and nominally plane surfaces, relative to each other or in relation to one or more datums.

To accurately achieve this aim, it is essential that the primary constituents, theoretically exact dimensions, tolerance zones, and datums are utilized. The tolerance zone is symmetrically disposed about its theoretically exact location.

Utilizing these primary constituents ensures positional tolerances do not accumulate when dimensions are arranged in a chain, as would be the case if the feature pattern location were to be specified by coordinate tolerances.

*Note:* The practice of locating groups of features by positional tolerancing and their pattern location by coordinate tolerances is no longer recommended by BS 8888 and BS EN ISO 5458.

Fig. 25.1 illustrates the advantage of specifying a circular tolerance zone to a feature located by positional tolerancing. Note that the shaded tolerance area represents an increase of more than 57%.



**Fig. 25.1** Indication of increase in tolerance area when specifying a circular zone.

## Theoretically exact dimensioning (TED) (true-position)

True-position dimensioning defines the exact location on a component of features such as holes, slots, keyways, etc., and also differentiates between ‘ideal’ and other toleranced dimensions. True-position dimensions are always shown ‘boxed’ on engineering drawings; they are never individually toleranced, and must always be accompanied by a positional or zone tolerance for the feature to which they are applied.

The positional tolerance is the permitted deviation of a feature from a true position.

The positional-tolerance zone defines the region which contains the extreme limits of position and can be rectangular, circular, cylindrical, etc.

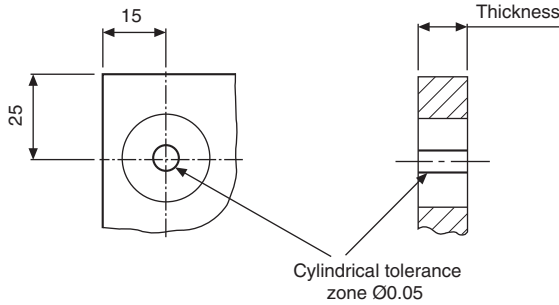


Fig. 25.2 Product requirement.

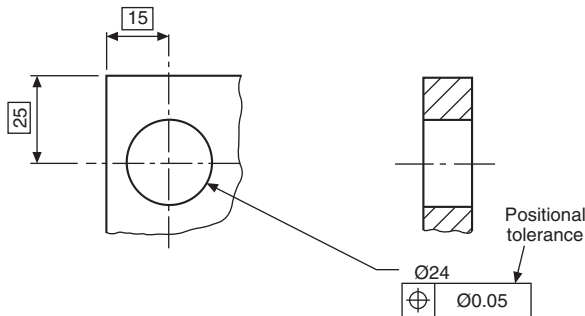


Fig. 25.3 Drawing instruction.

## Typical product requirement

In the examples shown in Figs. 25.2 and 25.3 the hole axis must lie within the cylindrical tolerance zone fixed by the true-position dimensions.

Some advantages of using this method are that:

1. interpretation is easier, since true boxed dimensions fix the exact positions of details;
2. there are no cumulative tolerances;
3. it permits the use of functional gauges to match the mating part;
4. it can ensure interchangeability without resorting to small position tolerances, required by the coordinate tolerancing system;
5. the tolerancing of complicated components is simplified;
6. positional-tolerance zones can control squareness and parallelism.

The following examples show some typical cases where positional tolerances are applied to engineering drawings.

### Case 1 (Figs. 25.4 and 25.5)

The axes of the four fixing holes must be contained within cylindrical tolerance zones of 0.03 diameter.

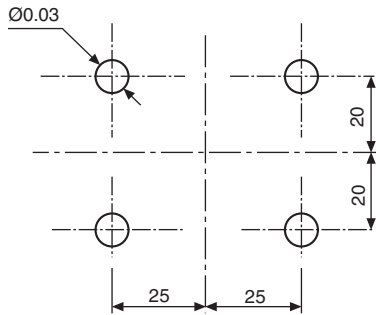


Fig. 25.4 Case 1: product requirement.

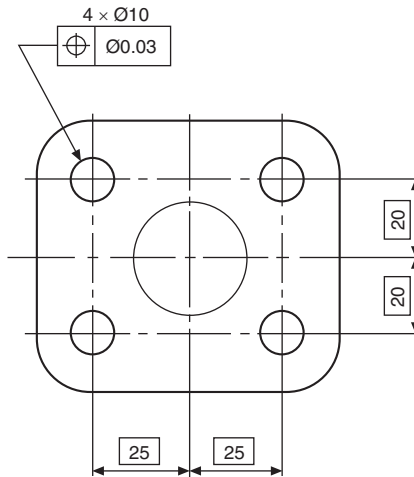
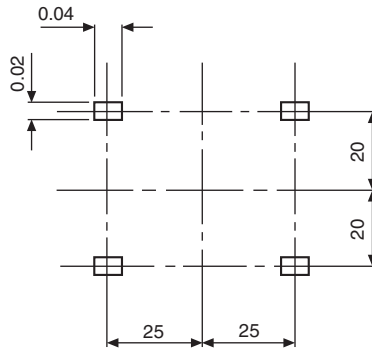


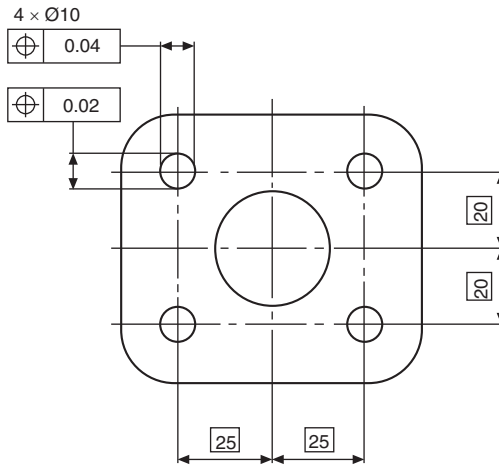
Fig. 25.5 Case 1: drawing instruction.

### Case 2 (Figs. 25.6 and 25.7)

The axes of the four fixing holes must be contained within rectangular tolerance zones  $0.04 \times 0.02$ .



**Fig. 25.6** Case 2: product requirement.



**Fig. 25.7** Case 2: drawing instruction.

In cases 3 and 4, the perpendicularity and coaxial symbols shown are constituents of the position characteristic, and could have been indicated by the position symbol equally as well.

### Case 3

[Fig. 25.8](#) shows a component where the outside diameter at the upper end is required to be square and coaxial within a combined tolerance zone with face A and diameter B as the primary and secondary datums.

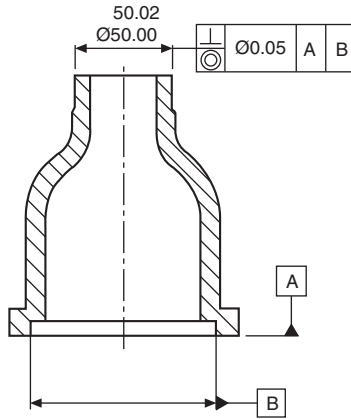


Fig. 25.8 Case 3.

### Case 4

In the component illustrated in Fig. 25.9, the three-dimensional features are required to be perfectly square to the datum face A, and also truly coaxial with each other in the maximum material condition.

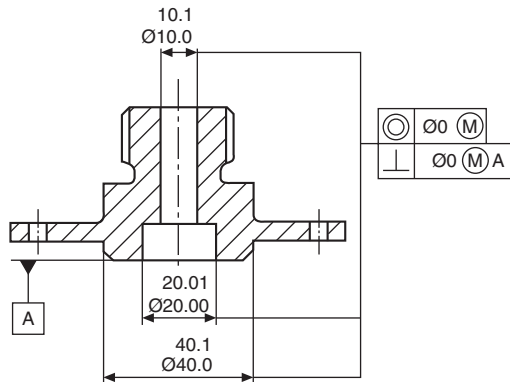


Fig. 25.9 Case 4.

### Case 5 (Figs. 25.10 and 25.11)

The six boltholes on the flange in Fig. 25.10 must have their centers positioned within six tolerance zones of  $\varnothing = 0.25$  when the boltholes are at their maximum material condition (i.e. minimum limit of size).

Note in Fig. 25.11 that all the features in the group have the same positional tolerance in relation to each other. This method also limits in all directions the relative displacement of each of the features to each other.

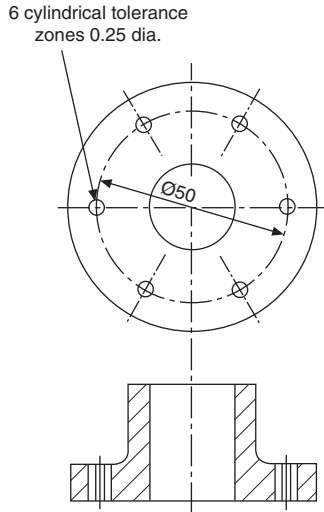


Fig. 25.10 Case 5: product requirement.

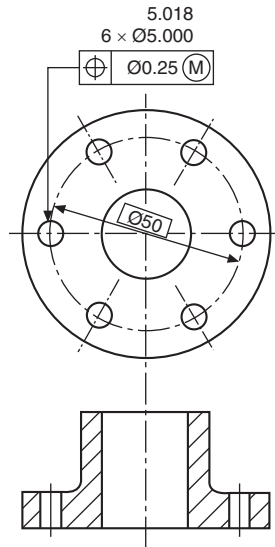
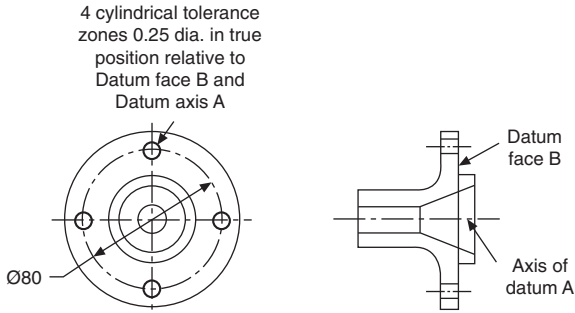


Fig. 25.11 Case 5: drawing instruction.

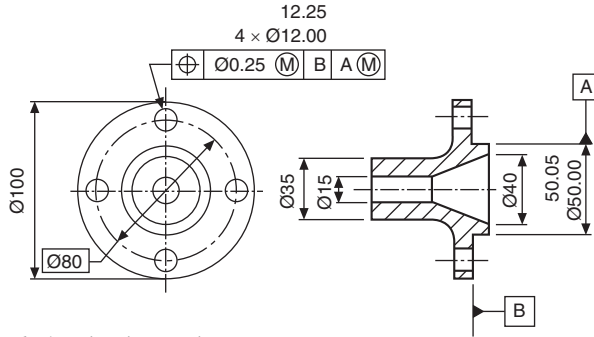
**Case 6 (Figs. 25.12 and 25.13)**

The group of holes in Fig. 25.12, dimensioned with a positional tolerance, is also required to be positioned with respect to the datum spigot and the face of the flange.

Note in Fig. 25.13 that the four holes and the spigot are dimensioned at the maximum material condition. It follows that, if any hole is larger than 12.00, it will



**Fig. 25.12** Case 6: product requirement.



**Fig. 25.13** Case 6: drawing instruction.

have the effect of increasing the positional tolerance for that hole. If the spigot is machined to less than 50.05, then the positional tolerance for the four holes as a group will also increase.

### Case 7

Fig. 25.14 shows a drawing instruction where the group of equally spaced holes is required to be positioned relative to a coaxial datum bore.

### Case 8

Fig. 25.15 shows a drawing instruction where a pattern of features is located by positional tolerancing. Each specific requirement is met independently. The product

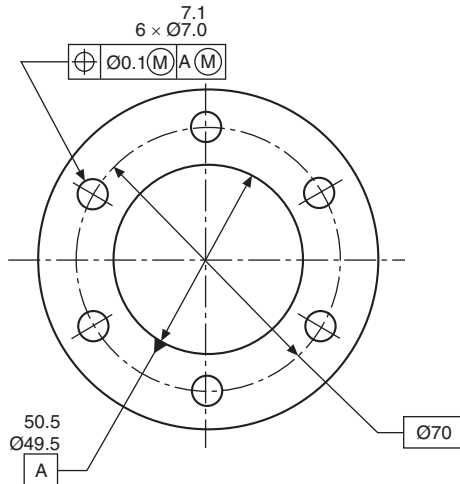


Fig. 25.14 Case 7: drawing instruction.

requirement in Fig. 25.16 shows that the axis of each of the four holes is required to lie within a cylindrical tolerance of  $\text{Ø} = 0.01$ . The positional tolerance zones are located in their theoretically exact positions to each other and perpendicular to datum A.

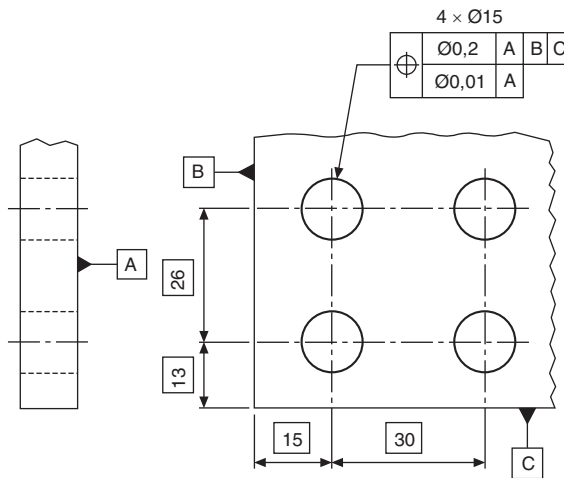
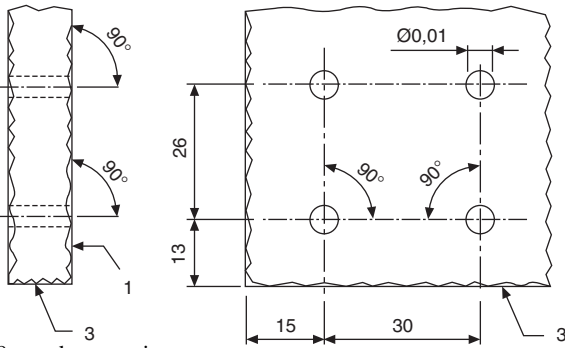
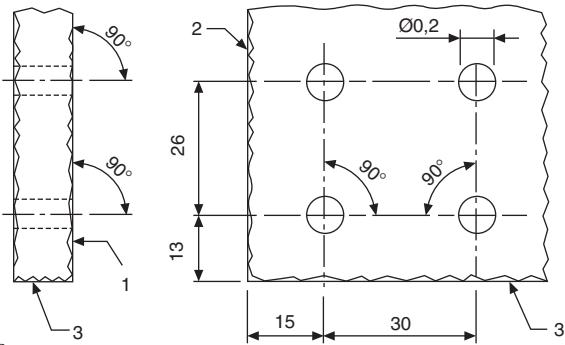


Fig. 25.15 Case 8: drawing instruction.



**Fig. 25.16** Case 8: product requirement.



**Fig. 25.17** Case 8.

In [Fig. 25.17](#), the axis of each of the four holes must lie within the cylindrical tolerance zone of  $\varnothing = 0.2$  and the cylindrical tolerance must lie perpendicular to datum A and also be located in their theoretical exact positions to each other and to datums B and C.

Note that in product requirement drawings, [Figs. 25.16 and 25.17](#), simulated datums A, B, and C are numbered 1, 2, and 3.

Further information may be obtained with reference to BS EN ISO 5458.

## Graphical symbols to indicate surface texture

The quality and type of surface texture has a direct connection with the manufacturing cost, function and wear of a component. Each of the symbols shown below has their own special interpretation. Individual surface texture values and text may be added to the symbols. The basic graphical symbol is shown in Fig. 26.1. The center line between the lines of unequal length is positioned square to the considered surface.

The symbol should not be indicated alone, without complementary information. It may, however be used for collective indication.

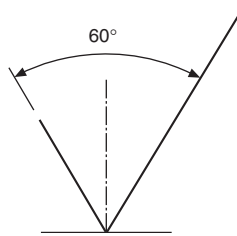


Fig. 26.1 Basic graphical symbol.

## Expanded graphical symbols

Fig. 26.2 shows the symbol indicating that removal of material is required. Fig. 26.3 shows the symbol indicating that removal of material is not permitted.

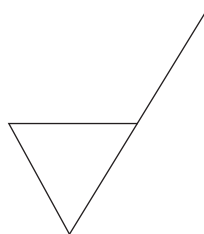
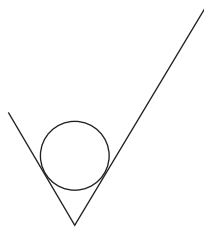


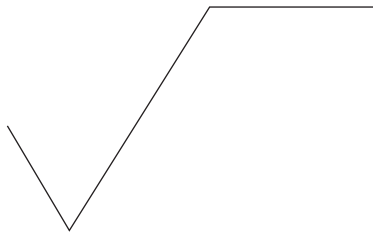
Fig. 26.2 Symbol indicating removal of material.



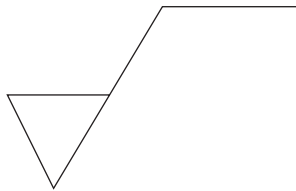
**Fig. 26.3** Symbol indicating removal of material is not permitted.

## Complete graphical symbols

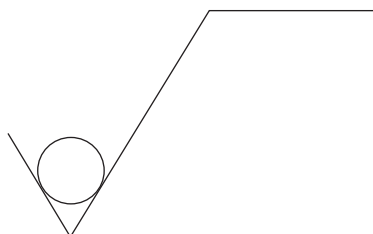
*Note:* If complementary requirements for surface texture characteristics are required, then a line is added to the longer arm of the symbols, as shown below. Any manufacturing process permitted, see [Fig. 26.4](#). Removal of material required, see [Fig. 26.5](#). Removal of material not permitted, see [Fig. 26.6](#).



**Fig. 26.4** Complimentary requirements - any manufacturing process permitted.



**Fig. 26.5** Complimentary requirements - removal of material required.



**Fig. 26.6** Complimentary requirements - removal of material not permitted.

## 'All surfaces around a workpiece' graphical symbol

When the same surface texture is required on every surface around a workpiece, then a small circle is added to the symbol as shown in Fig. 26.7. The texture applies to all eight sides. If ambiguity is considered likely, then each surface may have its own independent symbol.

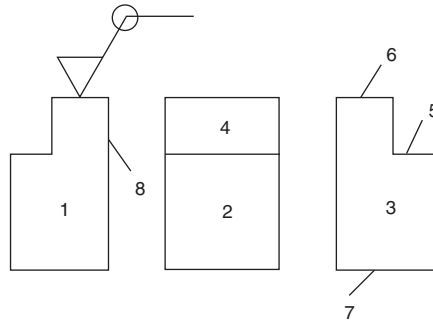


Fig. 26.7 Symbol indicating all surfaces.

## Composition of complete graphical symbols for surface texture

To avoid ambiguity, it may also be necessary to add additional requirements to the surface texture symbol and its numerical value, i.e. machining allowances, manufacturing process, sampling length and surface lay.

## Mandatory positions for complementary requirements

Fig. 26.8 shows mandatory positions of associated surface texture requirements. Note that in accordance with BS EN ISO 1302 the position 'X' is no longer used. Only positions a, b, c, d, and e should be used. Position 'a' indicates one single surface texture requirement. Positions 'a' and 'b' indicate two or more surface texture

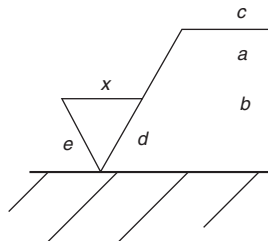


Fig. 26.8 Mandatory positions for requirements.

requirements. Position 'c' indicates manufacturing method, treatment, coating or other process. Position 'd' indicates surface lay. Position 'e' shows machining allowance.

Three principal groups of surface texture parameters have been standardized in connection with the complete symbol and are defined as R, W, and P profiles. The R profile series relates to roughness parameters. The W profile series relates to waviness parameters. The P profile series relates to structure parameters. The Ra value is the most commonly specified value throughout the world and examples follow in this chapter. Fig. 26.9 illustrates an application with a single Ra requirement. Fig. 26.10 shows an application with an upper and lower call out requirement. Fig. 26.11 shows examples of position and orientation on various surfaces. Note that the general rule when reading drawings is to read from the bottom or the right-hand side of the drawing. Fig. 26.12 is a typical application in connection with features of size of mating parts. Fig. 26.13 and 26.14 show examples of typical tolerance frames for geometrical tolerance applications.

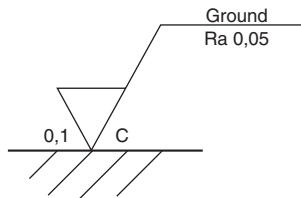


Fig. 26.9 Symbol with Ra requirements.

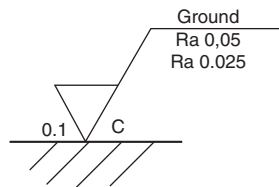


Fig. 26.10 Symbol with upper and lower Ra requirements.

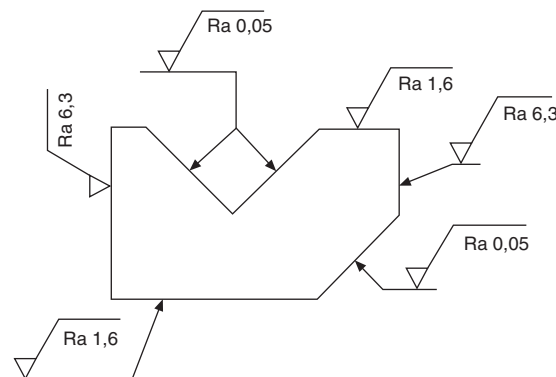
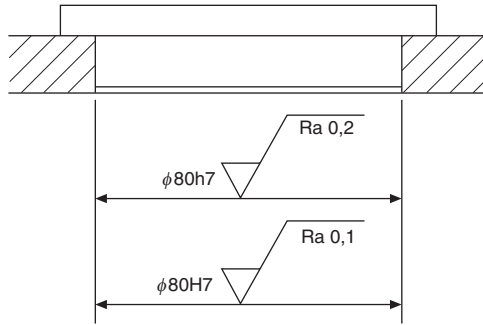
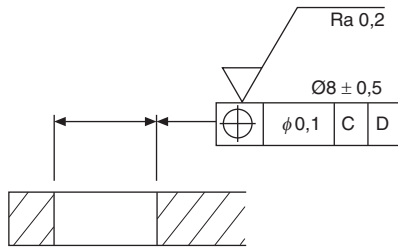


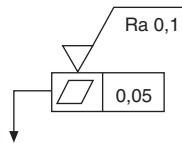
Fig. 26.11 Recommended position and orientation of symbols in relation to surfaces.



**Fig. 26.12** Symbols relating to mating parts.



**Fig. 26.13** Symbol attached to geometrical tolerance.

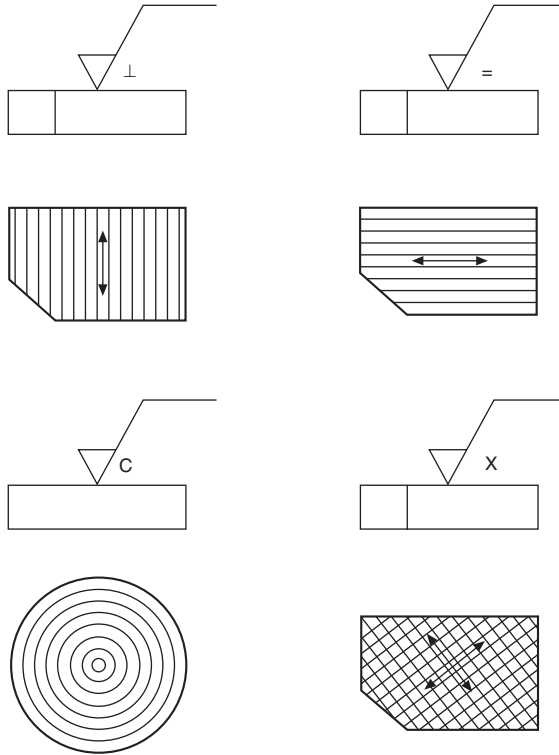


**Fig. 26.14** Symbol attached to geometrical tolerance.

Further information on this specialized area of Metrology is given in BS EN ISO 1302, Indication of Surface Texture in Product Documentation. The examples in Fig. 26.15 show methods of indicating four typical examples of surface lay.

- The lay is parallel to the plane of projection of the view where the symbol is drawn. The 'equals' symbol is added to the graphical symbol in the position shown. An arrow is indicated on the workpiece for clarification.
- The lay is perpendicular to the plane of projection and the symbol drawn is an inverted letter 'T'.
- The lay crosses the workpiece in two oblique directions indicated by the letter 'X'.
- The lay consists of concentric circles and the symbol used is the letter 'C'.

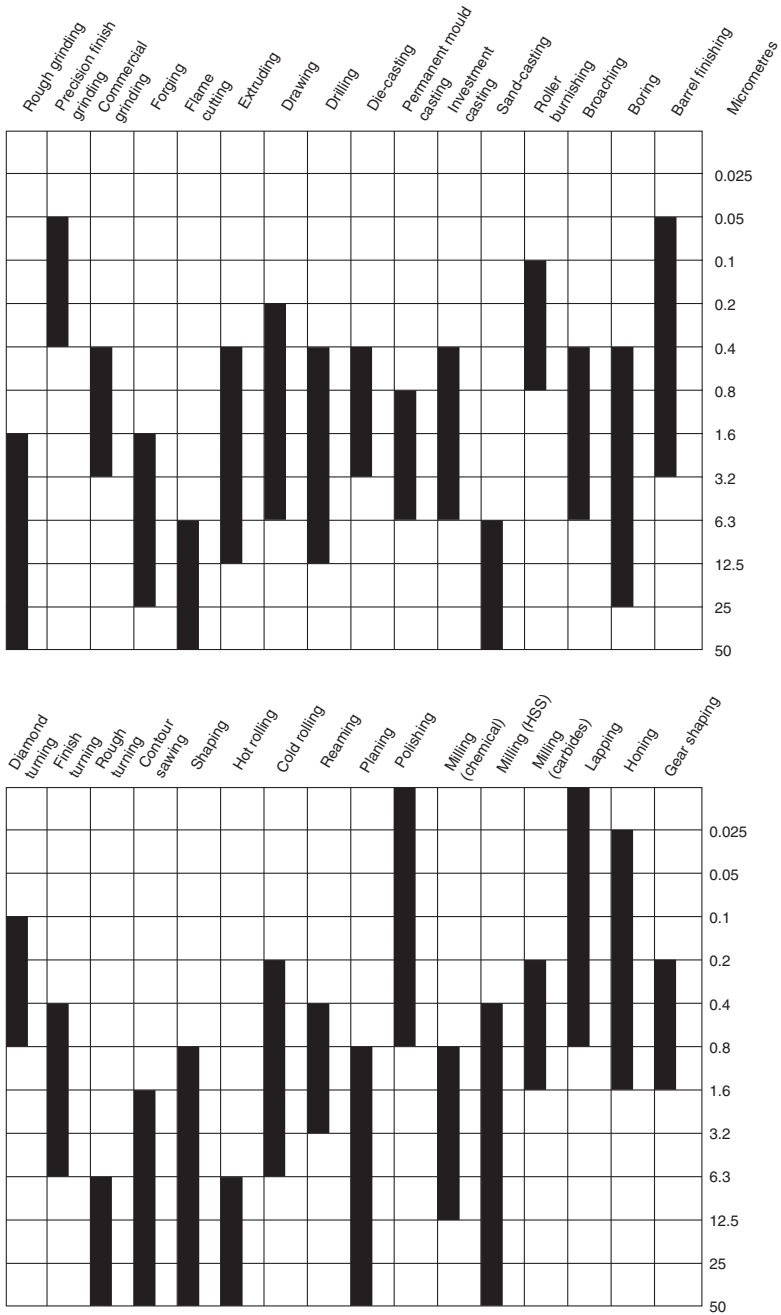
The Standard also states that where a surface pattern is required which is not covered by BS 8888, an explanatory note shall be added to the drawing.



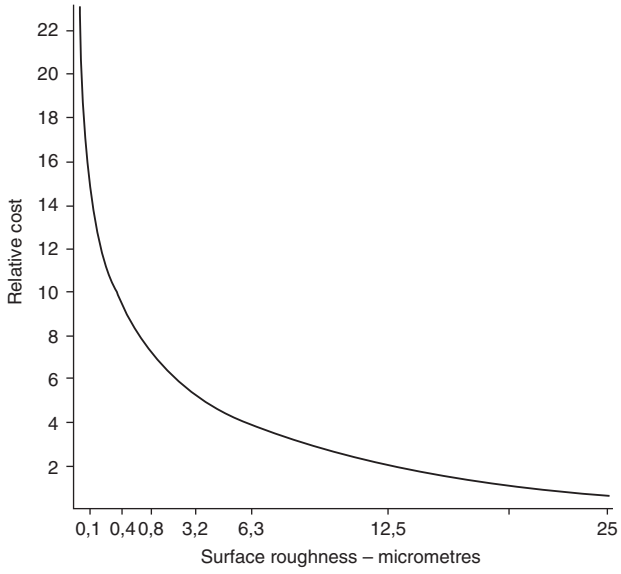
**Fig. 26.15** Symbols indicating surface lay.

**Fig. 26.16** shows approximate Ra surface roughness ranges for components manufactured by some common production methods. This information can only be approximate, since finish depends on many factors, such as the skill of the machinist, the accuracy and condition of the machine, the speeds and feeds selected for the operation, and the quality and condition of the cutting tools.

The approximate relationship between surface roughness and the cost of producing such a finish is shown in **Fig. 26.17**. The cost of rough machining can be considered as the zero datum on the y axis of the graph, and other processes can be compared with it. For example, a finish of  $6.3 \mu\text{m}$  produced by grinding may well cost four times as much as rough machining. Many factors contribute toward production costs, and this information again can be only approximate.



**Fig. 26.16** Approximate Ra surface roughness ranges obtainable by various common production processes.



**Fig. 26.17** Approximate relationship between surface roughness and cost.

# Surface finish and corrosion of metals

27

## Surface finish

The term *surface finish* is often confused with *surface texture*; however, these are two completely different aspects of engineering which relate to the condition of a surface of a part. *Surface finish* relates to a final coating applied to the surface of a part; this could range from being simply oiled, painted, varnished, lacquered, anodized, coated, galvanized or plated. *Surface texture* (see Chapter 26) is the physical surface roughness of the surface which can apply with or without any surface finish.

Surface finishes can be selected for corrosion protection, wear protection or decorative purposes. In addition to considering the mechanical performance of a design, designers should also consider the in-service environment the part will be subjected to as this will dictate parent material and surface finish selection. In some cases the natural state of the material, i.e. stainless steels or aluminum alloys, are often sufficient to meet these needs of corrosion protection.

Surface coatings provide a barrier to corrosive environments and some coatings can also inhibit corrosion such as priming paints containing zinc chromes or phosphates. Some metal coatings provide sacrificial protection in the event that the coating is damaged by acting as a consumable electrode (anode) in a galvanic cell. For sacrificial protection to work it is important to ensure that the coating metal is less noble than the parent metal within the corrosive environment.

Barrier coatings provide an impervious barrier between the parent metal and the corrosive environment. They must completely cover the part or the area to be protected and be of a sufficient quality to resist wear and damage which could expose the parent metal. Paints, varnish, lacquers, vitreous enamels, plastics and metal coatings are good examples of barrier coatings. Anodizing (the thickening of the natural oxide on aluminum alloys by an acid process) also provides an effective barrier. Oils and greases also act as a barrier but require constant maintenance to afford total protection.

Metallic coatings can be applied by the following methods: hot dipping, sprayed metal, electro deposition, electroless deposition, sheradizing, vacuum deposition, powder coating and painting.

### **Hot dipped coatings**

Hot dipped coatings are produced by dipping the part into a bath of molten metal, usually zinc (sometimes tin). The part is submerged until it reaches the same temperature as the molten metal; it is then withdrawn with the rate of withdrawal governing the thickness of the coating. The inside of the coating is an alloy of the parent material

and the coating material; the outside of the coating is pure coating material. A multi bath process can be used to ensure the purity of the top layer.

Hot dipped galvanized coatings are used extensively for corrosion protection where fine tolerances are not required and surface texture is not an issue. This process is not suitable for heat treated parts because of the temperatures required for the process.

Refer to the following Standards for guidance on hot dipped coatings:

Standard	Guidance
BS 4921	Hot dipped galvanized coatings on fabricated iron and steel articles, specifications and test methods
BS EN ISO 14713-1	Zinc coatings – guidelines and recommendations for the protection against corrosion of iron and steel – general principles of design and corrosion resistance
BS EN ISO 14713-2	Zinc coatings – guidelines and recommendations for the protection against corrosion of iron and steel – hot dipped galvanizing
BS 4479-1	Design of articles that are to be coated – general recommendations

### ***Sprayed metal coatings***

Sprayed metal coatings are produced by spraying molten or softened metal directly onto the surface of the part to be protected. The effectiveness of the coating depends greatly on its adhesion to the surface of the part and the thickness of the coating; thin coatings have a better adhesion than thick coatings.

The molten metal can be produced by passing metal powder, wire or rods through a gas (usually acetylene or propane) and oxygen flame or a metal arc or a plasma arc within a spray gun, with the molten or softened metal generally being transferred to the part by compressed air. In the case of the plasma arc method, ceramics and plastics powder can also be sprayed.

Sprayed coatings cool rapidly (especially plasma sprayed) and as such this technique can be used to coat plastic components with a metallic finish.

Refer to the following Standards for guidance on sprayed metal coating:

Standard	Guidance
BS EN ISO 2063	Thermal spraying metallic and other inorganic coatings zinc, aluminum and their alloys
BS 2569-2	Sprayed metal coatings, protection of iron and steel against corrosion and oxidation at elevated temperatures
BS 4479-1	Design of articles that are to be coated – general recommendations
BS 4479-9	Design of articles that are to be coated – recommendations for thermally sprayed coatings

## ***Electrodeposited coatings***

Electroplating is usually carried out in a bath of electrolyte; this electrolyte consists of a salt of the metal to be deposited. The part to be plated is connected to the negative pole of a low voltage DC current (becoming the cathode) and submerged in the electrolyte. An anode made of the metal to be plated is connected to the positive pole and is submerged in the electrolyte, and metal is drawn from the anode and deposited on the part. Sometimes the anode may be made from an inert material and in this case the deposited metal is drawn from the electrolyte.

Uniformity of the thickness of the coating is difficult to control; generally, the deposited metal has an affinity for external corners and protrusions and less of an affinity for internal corners and holes.

Commonly the following metals are suitable for electroplating; zinc, nickel, copper, chromium, tin, silver and gold. Parts which are regularly handled should not be nickel plated as in some cases a form of dermatitis can develop.

Refer to the following Standards for guidance on Electroplated materials:

<b>Standard</b>	<b>Guidance</b>
BS EN ISO 1456	Metallic and other inorganic coatings – electrodeposited coatings of nickel, nickel plus chromium, copper plus nickel and copper plus nickel and chromium
BS EN ISO 2081	Metallic and other inorganic coatings – electroplated coatings of zinc with supplementary treatments on iron and steel
BS 1872	Electrodeposited tin coatings
BS EN ISO 4521	Metallic and other inorganic coatings – electrodeposited silver and silver alloy coatings for engineering purposes – specification and test methods
BS 7371 (series)	Electroplated coatings on threaded components
BS EN ISO 27874	Metallic and other inorganic coatings – electrodeposited gold and gold alloy coatings for electrical and engineering purposes
BS EN ISO 4525	Metallic coatings – electroplated coatings of nickel plus chromium on plastics
BS EN ISO 6158	Metallic coatings – electrodeposited coatings of chromium for engineering purposes
BS EN ISO 4526	Metallic coatings – electrodeposited coatings of nickel for engineering purposes
BS 4479-1	Design of articles that are to be coated – general recommendations
BS 4479-2	Design of articles that are to be coated – recommendations for electroplated and autocatalytic coatings

### ***Electroless nickel***

As the term implies, the electroless nickel process does not require an electric current. The most common form of electroless nickel plating produces a nickel phosphorus alloy coating. It is commonly used when corrosion protection, hardness and wear resistance are required and unlike electroplated nickel, it produces a uniform coating which can be beneficial when more complex features are involved. Electroless nickel coating can also be used to repair worn parts: coating thicknesses of up to 100  $\mu\text{m}$  can be applied and re-worked. The process is also suitable for coating non-conducting parts such as some plastics.

Refer to the following Standards for guidance on electroless nickel coatings:

<b>Standard</b>	<b>Guidance</b>
BS 4479-1	Design of articles that are to be coated – general recommendations
BS 4479-2	Design of articles that are to be coated – recommendations for electroplated and autocatalytic coatings
BS EN ISO 4527	Metallic coatings – autocatalytic (electroless) nickel–phosphorus alloy coating, specifications and test methods

### ***Sheradized coating***

The sheradizing process is a method of applying a zinc coating to the surface of ferrous components. The process involves heating the part while it is in contact with zinc powder in a sealed drum. Sheradizing produces a more uniform and thinner coating than the hot dipped galvanizing process, making it suitable for threaded parts; however, the size of the part is limited to the size of the drum available to carry out the process.

Refer to the following Standards for guidance on sheradized coatings:

<b>Standard</b>	<b>Guidance</b>
BS 4479-1	Design of articles that are to be coated – general recommendations
BS 4479-3	Design of articles that are to be coated – recommendations for sheradizing coatings
BS 4921	Sheradizing, coatings on iron and steel

### ***Anodizing***

Anodizing of aluminum and aluminum alloys is an electrolytic passivation process used to increase the thickness of the natural oxide layer on the surface. The part to

be treated forms the anode electrode of an electrical circuit. Anodizing increases corrosion resistance and wear resistance, and provides better adhesion for paint primers and glues than bare metal. Anodic films can also be used for a number of cosmetic effects, providing thick porous coatings that can readily absorb dyes. The anodized coatings are soft and porous and to achieve corrosion resistance they require sealing by immersion in hot water or a chromate bath. There are two main processes used to produce anodic coatings: the chromic acid process and sulfuric acid process. The chromic acid process produces a surface film that provides good protection against corrosion, which is also suitable for bonding by adhesives. The sulfuric acid process produces a surface film which is better suited to dyeing and after-sealing, and is very hard-wearing.

Designers should note that anodizing will result in dimensional changes; typically an increase of about half the film thickness can be expected.

Although commonly associated with the treatment of aluminum alloys, anodic films can also be applied to titanium, zinc, magnesium and tantalum.

Refer to the following Standards for guidance on anodic coatings:

Standard	Guidance
BS EN ISO 7599	Anodizing of aluminum and its alloys, general specification for anodic oxidation coatings on aluminum
BS ISO 10074	Anodizing of aluminum and its alloys, general specification for hard anodic oxidation coatings on aluminum and its alloys
BS 4479-1	Design of articles that are to be coated – general recommendations
BS 4479-5	Design of articles that are to be coated – recommendations for anodic coatings

### ***Vacuum deposited coating***

Vacuum deposition coatings are produced by the condensation of metal vapor directly onto the component within a vacuum chamber. The metal vapor is produced by heating the coating material on a filament or in a crucible. The film produced can be very thin and multiple layers of differing metals can be achieved.

Refer to the following Standards for guidance on vacuum deposited coatings:

Standard	Guidance
BS 4479-1	Design of articles that are to be coated – general recommendations
BS 4479-9	Design of articles that are to be coated – recommendations for low pressure and vacuum deposited coatings

## ***Powder coating***

Powder coating is applied as a free-flowing, dry powder. The coating is generally produced by applying a positive electric charge to the powder, which is then sprayed on the earthed object by compressed air and then accelerated toward the workpiece by the powerful electrostatic charge. The powder is then cured under heat to allow it to flow and form the coating. The powder may be of a thermoplastic or thermosetting type. Powder coating produces a harder and tougher finish than conventional paint.

Refer to the following Standards for guidance on powder coatings:

<b>Standard</b>	<b>Guidance</b>
BS 4479-1	Design of articles that are to be coated – general recommendations

## ***Painting***

Painting is probably the most common form of surface finishing. It provides a good barrier to corrosive attack, can prevent galvanic corrosion by being an insulator between two contacting dissimilar materials, and is decorative by being available in a variety of colors. Unfortunately, painted surfaces are susceptible to impact and abrasion damage and regular inspection, repair of damaged areas or re-painting will be necessary for continued protection.

Most metal surfaces require some preparation prior to painting; priming paint is usually applied as an undercoat which inhibits corrosion and provides a good surface for the final coat or coats.

Refer to the following Standards for guidance on painted coatings:

<b>Standard</b>	<b>Guidance</b>
BS 4479-1	Design of articles that are to be coated – general recommendations
BS 4479-4	Design of articles that are to be coated – recommendations for paint coatings and varnish coatings

## **Corrosion of metals**

The surfaces of many common metals deteriorate with the effects of atmospheric corrosion if exposed to the elements. This can initially lead to deterioration of appearance such as rusting and could possibly impact the performance of the part in terms of strength or functionality such as seizure of a moving part or thread.

The cost to industry of the effects of corrosion is considerable and generally these costs occur later in the product life cycle as in nearly all cases the part affected is in its in-service period and repair and/or replacement has costly implications in terms of

warranty or company reputation. The by-products of corrosion can also contribute to part failure by being abrasive, blocking or restricting fluid paths or short circuiting electronic components. Corrosion can be reduced by good design practices such as the consideration of the effects of the in-service environment, material contact compatibility (bimetallic contact) and ensuring there are no traps which could collect moisture or chemicals.

To counteract corrosion numerous forms of surface finish are available to the designer; in the main surface treatments are either 'active' or 'passive'. Active treatments contain substances which chemically impact the corrosion progress. Passive treatments form a barrier to prevent corrosive media from attacking the surface of the part. It is possible to include both forms of protection.

In general there are two types of corrosion: chemical corrosion and electrochemical corrosion. Chemical corrosion is often beneficial to the product and usually involves the direct interaction of the parent metal, gases such as oxygen and sulfur dioxide and high temperatures. The nature of the passive surface film produced has an important effect on subsequent corrosion. If the film is hard and unbroken then further corrosion is unlikely as is the case with relatively high chromium content alloy steels such as stainless steels and similarly high nickel alloy steels which resist corrosion at elevated temperatures. Electrochemical corrosion takes place when moisture is present and is usually harmful to the product. Pure water has a very low corrosive effect but when the likes of acids, alkalis or salts are dissolved the corrosive effect is greatly increased.

The most common types of corrosion are usually caused by environmental/atmospheric conditions and are collectively referred to as atmospheric corrosion. For atmospheric corrosion to take place water, either as a liquid or vapor, and oxygen must be present. This type of corrosion affects equipment exposed to outside environments with parts being affected by rain, atmospheric pollution and extremes of temperature; in addition to external corrosion, corrosion inside assemblies and sealed spaces is also probable. Equipment under cover in a shed or workshop can also be affected by atmospheric corrosion even though it is protected from the harshest environments. Condensation causes problems in most environments and it is worth noting that within a sealed space the initial temperature and humidity are the same as those at the time of sealing but, as the temperature changes, so can the humidity to the point where a reduction in temperature could increase humidity to above the dew point.

Although the detailed process of corrosion is complicated, a basic understanding of the facts will greatly assist the designer in material selection and finishing processes. The following common forms of corrosion, although not exhaustive, should be considered.

### ***Even or uniform corrosion***

This type of corrosion is identified by a uniform tarnish of the surface which is usually attributed to simple atmospheric attack; it is best exemplified by 'rust', which is commonly found on unprotected iron and steels. It occurs relatively evenly distributed over the surface of the parent material.

## Galvanic or bimetallic corrosion

When two dissimilar metals are joined together or are in contact with each other in the presence of an electrolyte (usually a conducting fluid), they will produce a galvanic cell (similar to an electric battery) and a potential will be established between the two metals equal to the sum of their electrode potentials. A current will flow between the metals with the anodic metal corroding (see Figs. 27.1 and 27.2). The rate of the resulting corrosion will depend on the conductivity of the electrolyte, the potential voltage set up between the two metals and the density of the anodic material. The potential voltage which will exist can vary with the environment but can be estimated by reference to the Galvanic Series, which today is easily accessed via the Internet.

In Fig. 27.1, a mild steel pipe is joined to a copper pipe; because mild steel is anodic to copper the mild steel pipe will corrode in the presence of an electrolyte (water).

In Fig. 27.2 a mild steel sheet has been tin plated. Tin has excellent corrosion resistance but if the plating is damaged, revealing the mild steel, corrosion of the mild steel will occur in the presence of water as mild steel is anodic to tin.

If the mild steel sheet had been zinc plated and had been similarly damaged, the opposite would occur: the zinc would corrode, being anodic to mild steel. It is likely that the mild steel would not corrode as long as the zinc remains in the vicinity of the damage providing sacrificial protection.

In general when dissimilar metals are used in a galvanic environment, corrosion cannot be completely eliminated but it can be reduced by selecting materials with a similar electrode potential or close to each other in the Galvanic Series, or by minimizing the anodic material and maximizing the cathodic material.

Table 27.1 gives approximate electrode potentials against a saturated calomel electrode in seawater at 25 °C. Metals grouped together have little potential to produce galvanic corrosion when used together.

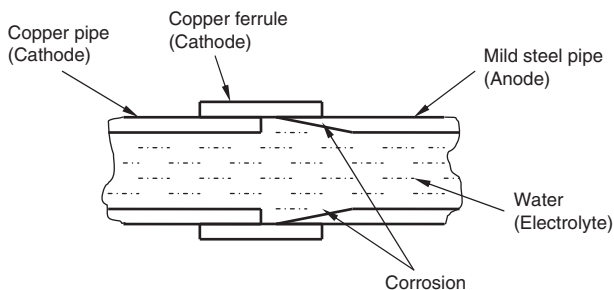
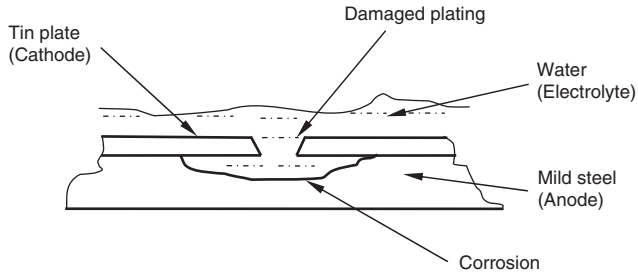


Fig. 27.1 Corrosion of a steel/copper pipe joint.



**Fig. 27.2** Corrosion on a steel sheet.

**Table 27.1** Electrode potentials of common materials.

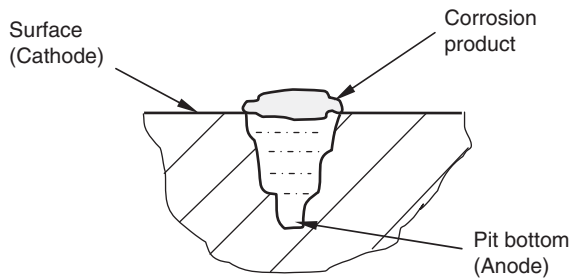
Metal	Electrode potential volts	Active (anodic)
Magnesium and its alloys	-1.60	
Zinc die casting alloy	-1.10	
Zinc plating on steel	-1.10	
Zinc coated galvanized steel	-1.05	
Aluminum cast and wrought	-0.75	
Aluminum alloy	-0.60	
Steel, carbon non-corrosion resisting	-0.7	
Steel, stainless	-0.35	
Lead	-0.55	
Tin/Lead solder	-0.50	
Tin plate	-0.50	
Copper, brass, bronze	-0.25	
Nickel – copper alloys	-0.25	
Nickel plating on steel	-0.15	
Silver solder	-0.20	
Silver	0	
Silver plating on copper	-0.5	
Titanium	0	
Gold	+0.1	
Platinum	+0.15	

*Note:* A saturated calomel electrode is a reference electrode which has a stable and well-known electrode potential.

## ***Pitting corrosion***

Pitting of metal is a form of galvanic corrosion where the cathode and the anode are both part of the same material. This may occur due to impurities in the material acting as one electrode in the galvanic cell. Pitting of stainless steel and aluminum alloys is often initiated by a break in the protective oxide film, for example on the surface of a component. Once a pit has formed corrosion occurs due to the surface of the material (cathode) having greater access to oxygen than the base of the pit (anode); corrosion is accelerated because the cathodic surface has a greater area than the anodic base of the pit. Corrosion by-products accumulate at the mouth of the pit assisting further corrosion by restricting the ingress of oxygen, see Fig. 27.3.

Crevice corrosion is similar to galvanic and pitting corrosion and can occur when different areas of the same metal are in contact with different concentrations of an electrolyte. The electrolyte accumulates in small volumes, for example in a crevice, under surface scale, under the head and around the shank of a fastener.



**Fig. 27.3** Pitting corrosion.

## ***Stress corrosion***

Stress corrosion is a combination of corrosion and fracture. Externally applied stresses and internal stresses caused by welding or forming can break any protective surface film and open up surface irregularities and capillary spaces; the corrosion attack occurs at these places. The rate of corrosion is dependent on the stress, its degree and environmental conditions; and failure of a component is likely in the continuing presence of stress. Designers can minimize stress corrosion by selecting appropriate materials, reducing externally applied stresses and stress-relieving the part if appropriate.

## ***Fretting corrosion***

Fretting corrosion can occur in most metals where there is vibration between mating surfaces and rotating parts. Stainless steel is particularly prone to attack and brass has resistance to attack. The corrosion product consists of oxidized particles which have been rubbed from the contacting surfaces. These particles are extremely abrasive and the corrosion results in pitting of the surface, unplanned wear between the

contacting surfaces, seizure of moving parts and a reduction in fatigue life. Good lubrication of moving parts is essential in reducing fretting corrosion.

### ***Weld decay***

Stainless steels with a carbon content above 0.03% are particularly susceptible to this form of corrosion and, as the term suggests, weld decay generally occurs near the weld in the area of the heat-affected zone which has been subjected to temperatures between 500 and 800 °C during the welding process. At these temperatures, chromium combines with carbon and precipitates as chromium carbide leaving the area with an insufficient chromium content to prevent corrosion. Weld decay can be prevented by heat treatment of the welded part or selection of material with a low carbon content, or selection of material which has been stabilized with titanium or niobium.

### ***Dezincification***

Dezincification can occur in brass with a zinc content above 15%. If the brass comes in contact with an electrolyte such as sea water, the zinc can go into solution, being replaced by deposited porous copper. There is little evidence of corrosion externally but the part will be considerably weakened and often fails as a result.

## **Design considerations to minimize the effects of corrosion**

- Select materials that are resistant to the corrosive environment to be encountered by the part.
- Design to eliminate galvanic corrosion by avoiding direct contact between dissimilar metals.
- Design to ensure the ratio of anodic to cathodic surface area is small.
- Design to avoid any traps where electrolyte can accumulate; alternatively provide a provision for drainage.
- Design to avoid stress concentrations.
- Design to prevent high frequency movements between mating parts.
- Select a protective finish that is resistant to the corrosive environment to be encountered by the part.
- Use active protective finishes, such as the less noble anodic materials, and if possible include additional material to protect by sacrificial corrosion.

# 3D annotation and product data management

28

Three-dimensional (3D) or ‘solid’ modeling is now used worldwide by industry, as the tool of choice for engineering design. Driven by the race between competitors to shorten the ‘time to market’ for their products, full exploitation of the benefits of using the 3D model as a master is essential, enabling the production of product data specifications (drawings), Additive Manufacture (AM) Rapid Prototyping, Computer Aided Manufacture (CAM), Computer Aided Inspection (CAI) and Finite Element Analysis (FEA).

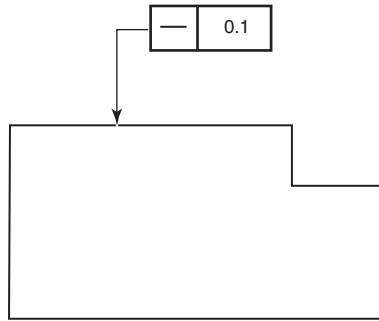
There are many examples of ‘paperless manufacture’, i.e. a product being manufactured from a model, by CAM or AM, without the aid of drawings or any supplementary specification. In this application, the accuracy and uncertainty of the manufacturing process is understood and deemed acceptable by the designer for the finished product. To ensure repeatability the manufacturing process must be tightly controlled as any change could impact the product performance. Unfortunately, this method does not lend itself readily to changes in manufacturing environments such as differing machine tools or global manufacturing, so it is important that the full design intent can be added to the model.

Despite the common use of 3D modeling, two-dimensional (2D) drawings are still widely used to enable manufacture. The introduction of geometrical product specification (GPS) has given the designer the tools to convey full design intent using unambiguous 2D drawings. By using annotated 3D models the requirement to produce 2D drawings has been reduced.

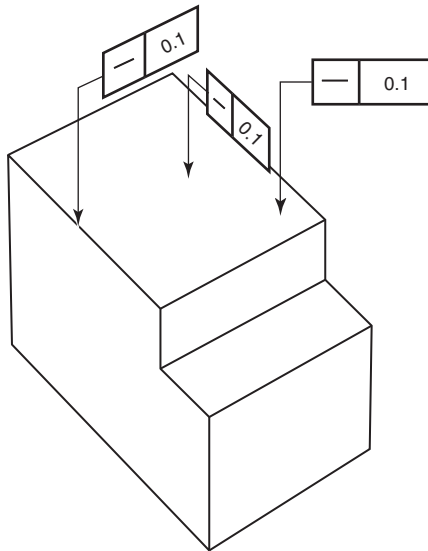
Two Standards relating to 3D annotation exist: ASME Y14.41 Technical product documentation – Digital product definition data practices, and ISO 16792 – Technical Product Documentation – Digital Product Definition Data Practices (which is closely aligned to ASME 14-41 but adapted to suit the ISO system). Additional methods of 3D specification are being developed by ISO and are, or will be, included in the Standards such as ISO 1101 – Geometrical Product Specification – Geometrical Tolerancing – Tolerances of Form, Orientation, Location and Run-out, and ISO 5459 – Geometrical Product Specification – Geometrical Tolerancing Datums and Datum Systems.

These new Standards have been introduced to standardize 3D annotation. For example: 3D CAD systems on the market today differ slightly in the way of constructing models, assigning attributes, determining associativity and specifying tolerances; 2D drawings contain tolerances that are view or direction-dependent, e.g. straightness (see Fig. 28.1) and the limit of the tolerances (see Fig. 28.3) and, as 3D models are not confined to orthographic views, the positioning of tolerance indicators often requires controlling. In the case of Fig. 28.2 there are many orientations in which a tolerance indicator can be applied with only the one in the center being the same as shown in Fig. 28.1. To ensure there is no ambiguity the direction of tolerances can be further

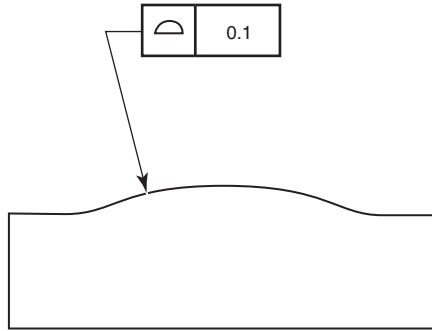
defined (see Fig. 28.14). In Fig. 28.3, without the use of a Between property indicator (see Chapter 16 and Fig. 28.9), it could be assumed that the tolerance applies to the entire top surface. In 3D the software can define several geometrical features for the same surface (see Fig. 28.4) so it is important that the tolerance requirements are fully defined i.e. use of a Between property indicator and/or the use of the tolerance modified Common Zone (see Chapters 22 and 23). These examples highlight the need for a consistent approach toward 3D annotation which ensures that any rules introduced into new and existing Standards are equally applicable to 2D and 3D specification or application; see Figs. 28.16 and 28.17 for typical examples.



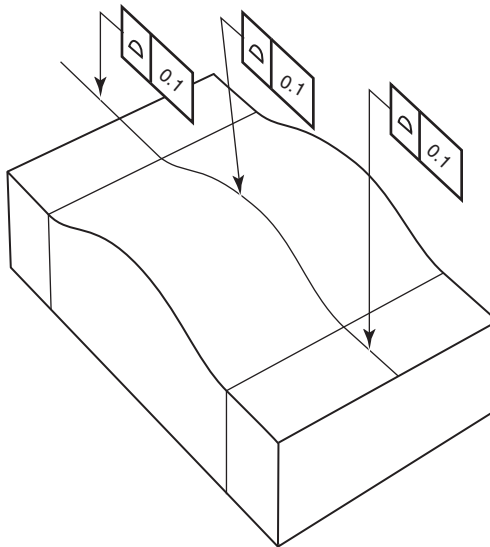
**Fig. 28.1** In 2D the choice of view determines the location and orientation of the feature.



**Fig. 28.2** Possible 3D annotation.



**Fig. 28.3** In 2D the choice of view determines the limits of the tolerated feature.



**Fig. 28.4** Surface comprising several geometric features.

The following are examples of alternative methods of specifying tolerances within 2D and 3D applications together with the conventional method. Both methods are equally applicable and the designer should decide which method best suits their requirements. It is strongly recommended that where a product is specified in both 2D and 3D formats the same method of specification is used on both.

## Axis or median feature

[Fig. 28.5](#) illustrates an alternative way of referring the tolerance to an axis or median feature. In this method the tolerance frame is connected to the feature by a leader line terminating with an arrowhead pointing directly at the surface, but with the addition of

the modifier symbol (median feature) placed to the right hand end of the second compartment of the tolerance frame.

Fig. 28.6 illustrates the conventional method of referring the tolerance to an axis or median feature.

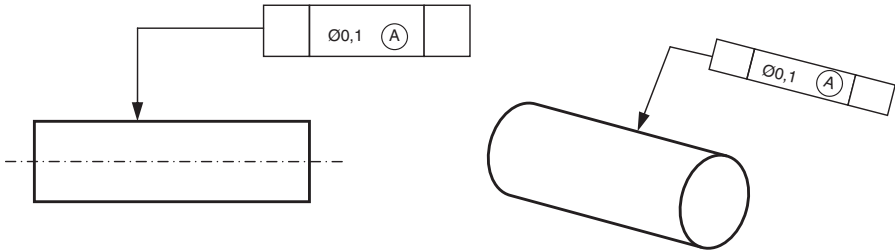


Fig. 28.5 Alternative method.

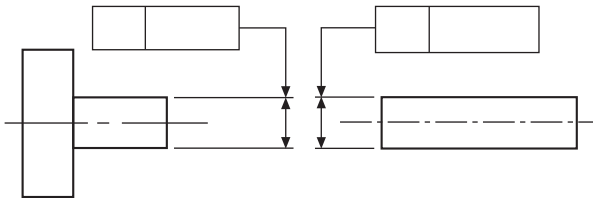


Fig. 28.6 3D annotated model.

## Projected tolerance zone

Fig. 28.7 illustrates an alternative to indicating the projected tolerance zone without using supplemental geometry; the length of projection can also be specified indirectly by adding the value, after the symbol, in the tolerance frame. This method of indication only applies to blind holes.

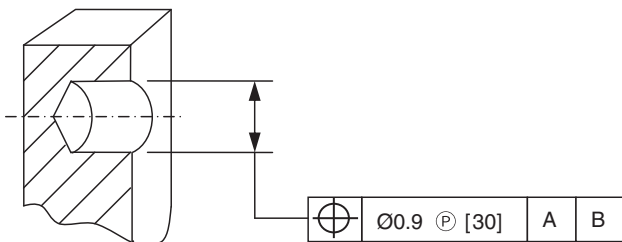
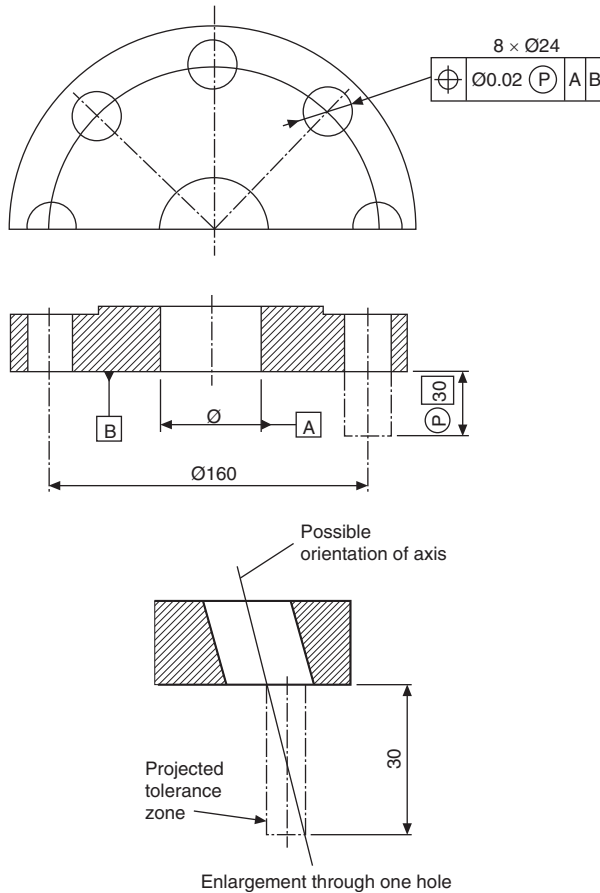


Fig. 28.7 Alternative method.

Fig. 28.8 illustrates the conventional method of specifying a projected tolerance zone.



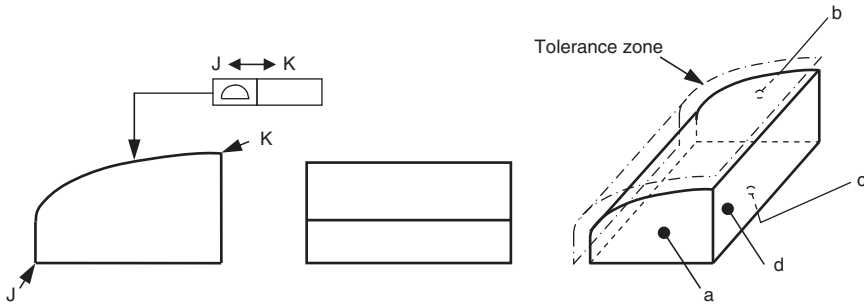
**Fig. 28.8** Conventional method.

## Indicating a tolerance zone between two points

During the development of 3D annotation it was established that there was some ambiguity in identifying the extent (start and finish) of tolerance zones, such as profile of a surface. Simplistically, where a surface is the product of a couple of features such as a curve and a flat, it was common practice to assume that both elements were one surface. When 3D modeling it becomes more obvious that each feature can be a separate entity and, as such, any tolerance indicated by a leader line could only apply to that entity. To give the designer more flexibility and to eliminate multi tolerance indications the 'between' symbol has been introduced. This introduction has aligned the ISO (ISO 1101) with ASME (Y14-5) where the 'between' symbol has been widely used.

The between symbol ' $\leftrightarrow$ ' is used between two letters identifying the start and the end of the considered tolerated zone. This zone includes all segments or areas between the start and the end of the identified features.

To clearly identify the tolerance zone, the tolerance frame is connected to the compound tolerated feature by a leader line, terminating with an arrowhead on the outline of the compound tolerated feature (see example in Fig. 28.9). Note that the tolerance does not apply to surfaces a, b, c, and d.



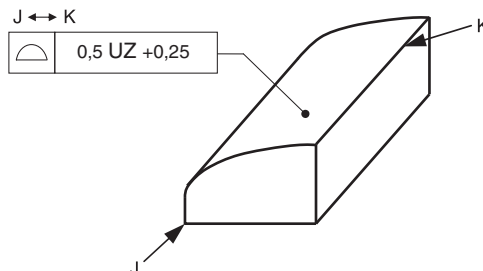
**Fig. 28.9** Tolerance zone between two points.

If the tolerance zone applies to part of a feature or surface it can be positioned by using theoretical exact dimensions.

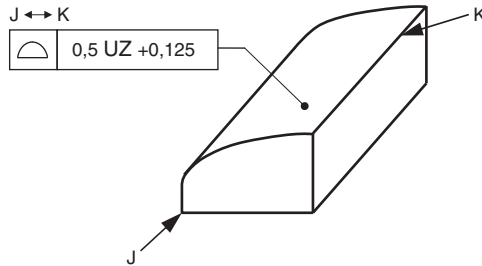
If the tolerance value is variable along the selected compound tolerated feature the symbol called 'From ... to' (see Fig. 22.1C) can be used. The tolerance band is proportional to the distance between the two points with the largest tolerance applying at the start point and the smallest tolerance applying at the finish point.

## Unilateral and unequal profile tolerance

To reduce the need to use supplemental geometry, new symbology has been introduced to indicate unilateral and unequal tolerance zones. See Chapter 23 for rules of application (see Figs. 28.10 and 28.11).



**Fig. 28.10** Application of unilateral profile tolerance.



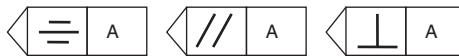
**Fig. 28.11** Application of unequal profile tolerance.

## Indicating the direction of tolerance zones

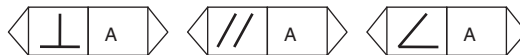
Tolerances specified on 2D drawings are often associated with the orthographic view to which they are applied, i.e. view-dependent. 3D models are not confined to orthographic projection and as such it is vital that the application of tolerances is unambiguous. If the designer feels there is any ambiguity in specifying the direction of a tolerance zone the indicators shown in Figs. 28.12 and 28.13 may be applied after the tolerance frame (see Figs. 28.14 and 28.15). In Fig. 28.14 the straightness tolerance applies parallel to datum face A. In Fig. 28.15 the tolerance is applied at the specified angle to datum A.

For intersection planes, the symbol symmetrical, parallel, or perpendicular, defining how the intersection plane is derived from the datum, is placed in the first compartment of the intersection plane indicator.

For orientation planes, the symbol perpendicular, parallel, or angular, defining how the intersection plane is derived from the datum, is placed in the first compartment of the intersection plane indicator (Figs. 28.12 and 28.13).



**Fig. 28.12** Intersection plane indicators.



**Fig. 28.13** Orientation plane indicators.

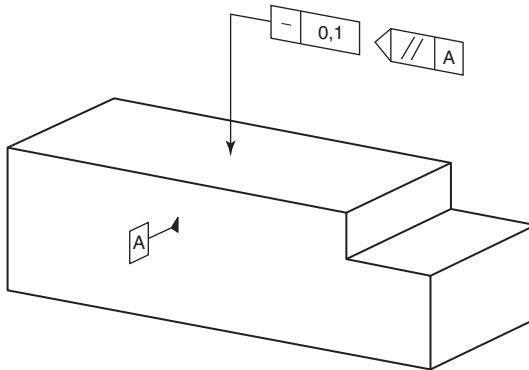


Fig. 28.14 Application of intersection plane indicators.

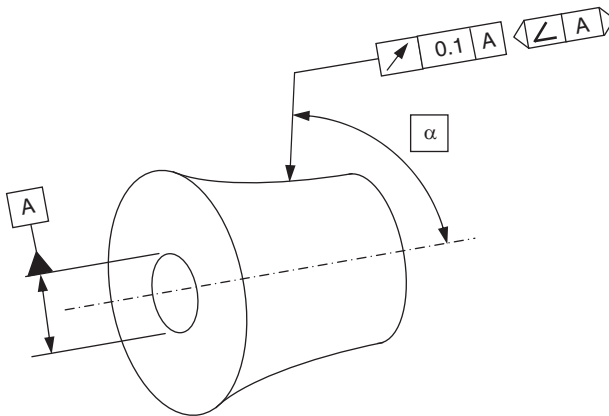


Fig. 28.15 Application of orientation plane indicators.

## Data management

It is important that the 3D data is managed as detailed in ISO1142 – Technical Product Documentation – Document Management. This will enable the control and tracking of the data sets throughout the product life cycle. It is recommended that in addition to the final design data, work in process, design review data, checked status, release status, modification details, and manufacturing details are managed. See Fig. 28.18 of a typical data set and Fig. 28.19 for a typical content of a 3D model.

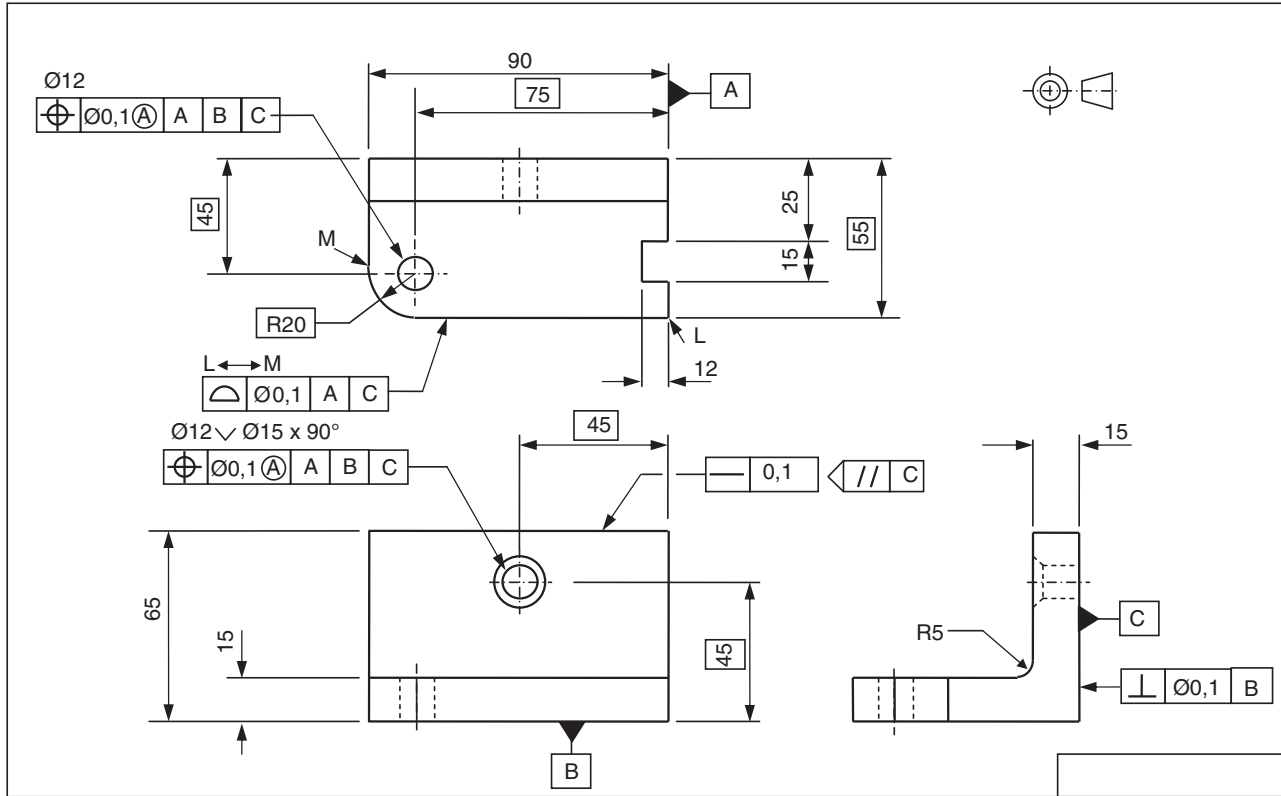
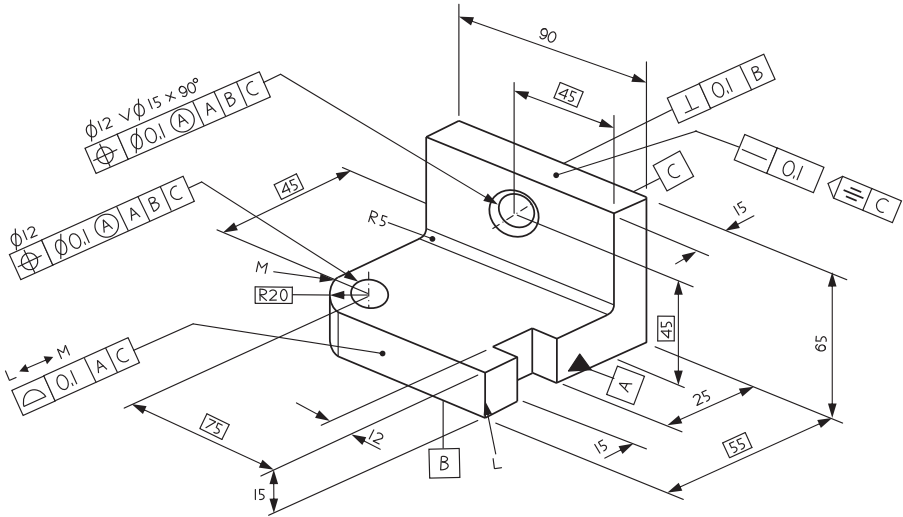
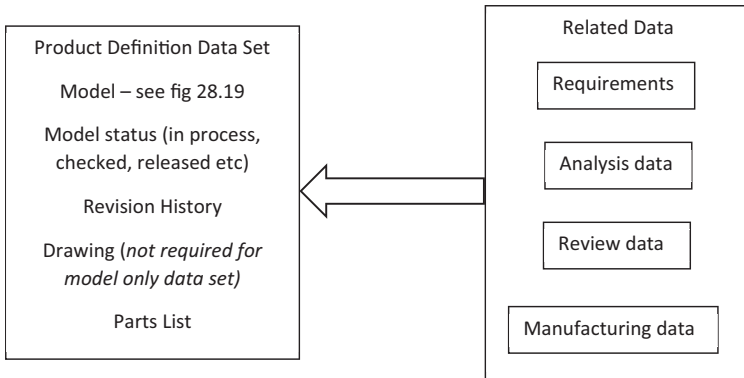


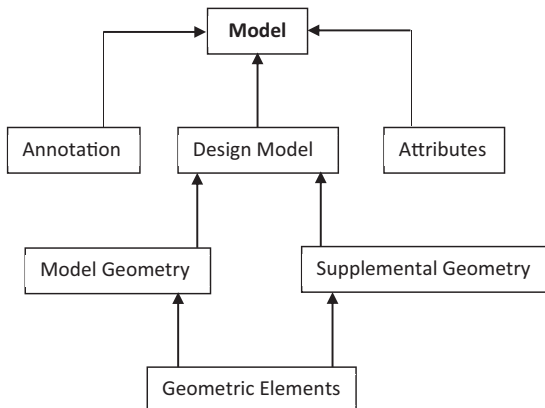
Fig. 28.16 Typical 2D drawing. Note the intersection plane indicator is optional in this application.



**Fig. 28.17** Annotated model.



**Fig. 28.18** Typical data set.



**Fig. 28.19** Typical content of a 3D model.

# The Duality Principle – the essential link between the design intent and the verification of the end product

## Introduction

In today’s modern world of mass production and the sophisticated techniques available to the ‘manufacturing and verification fields of operation’ it is essential that the communication between all parties involved in the production of a workpiece, from its functional concept through to the end product, be as complete as possible, without ambiguity, in order to minimize any unaccountable uncertainties that may inadvertently be found (see Fig. 29.1). Compliance with the Duality Principle greatly assists in this aim.

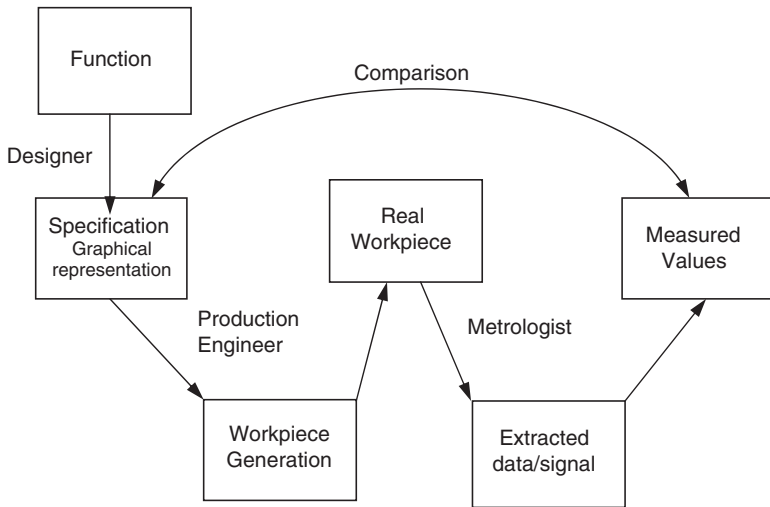


Fig. 29.1 Relationship between design and the verification of an actual finished part.

## Design specification and verification

When a workpiece is inspected or verified a number of stage processes take place (see Fig. 29.2). Because many of these stage processes are common practices, they are not consciously classified and considered in just the systematic way we already do things. Now, by identifying and classifying each of these individual stage

operations, a common language is created for use between the designer and verification engineer, which must greatly assist and improve the communication and understanding between them. The classifications given to these stage operations are partition, extraction, filtration, association, collection and construction.

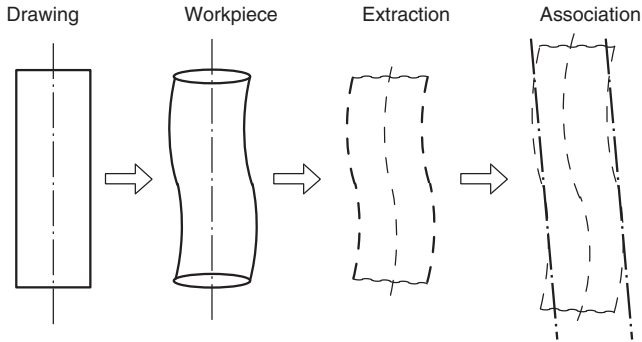


Fig. 29.2 The link between the design intent and metrology.

Fig. 29.3 shows these processes mirrored to each other at each operation between the design intent and the verification stage process, in order to achieve an acceptable end product. This essential link is known as the *Duality Principle*.

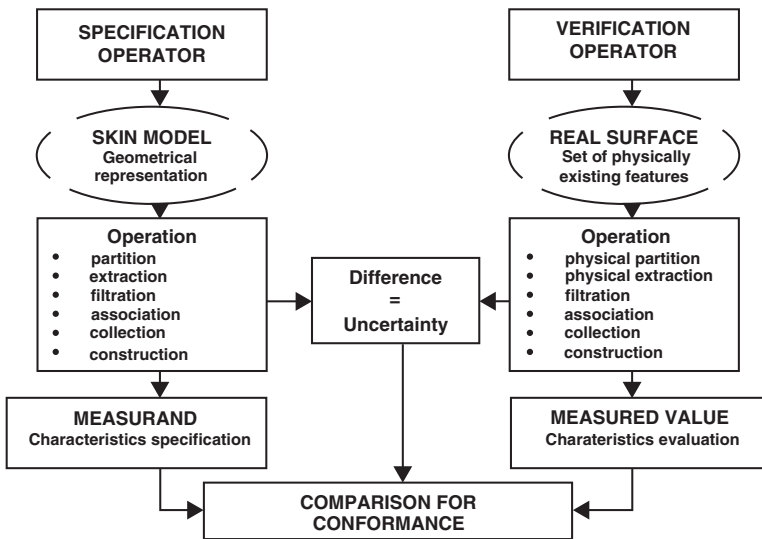
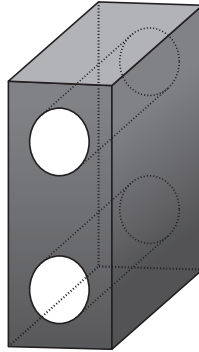


Fig. 29.3 The Duality Principle.

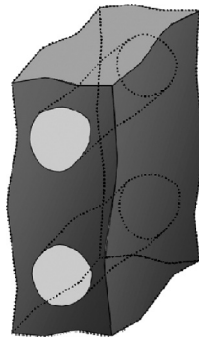
Detailed illustrations and explanations of each stage operation are shown in Figs 29.4–29.11 depicting the Duality Principle.

Fig. 29.4 illustrates the simplistic design intent, i.e. the nominal model as conceived by the designer delineated in perfect geometry.



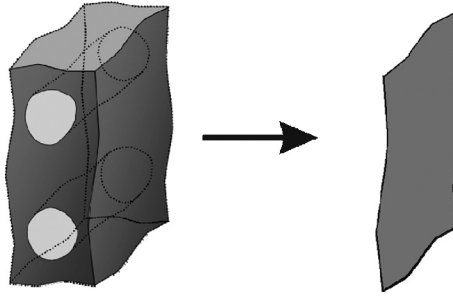
**Fig. 29.4** Nominal model.

Fig. 29.5 illustrates the realistic design intent, i.e. the skin model representing the imperfect geometry of the interface of the workpiece with its surrounding medium, as perceived by the designer.



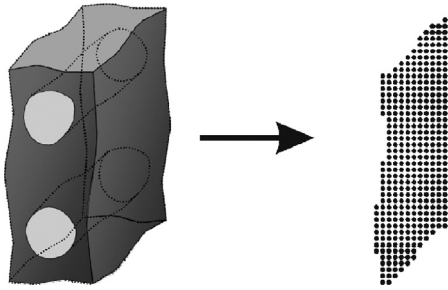
**Fig. 29.5** Skin model.

Fig. 29.6 illustrates the term *partition*, this being the operation that takes place when a feature or features such as flat surfaces, cylindrical surfaces, or curved surfaces are partitioned to obtain from the skin model or real surface(s) the non-ideal surfaces corresponding to the nominal features.



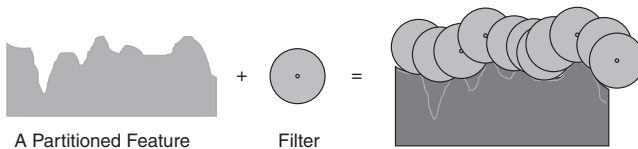
**Fig. 29.6** Partition.

**Fig. 29.7** illustrates the term known as *extraction*, this being the operation that results in the representation of the surface (skin model or real surface), obtained by extracting a finite number of points from a partitioned surface.



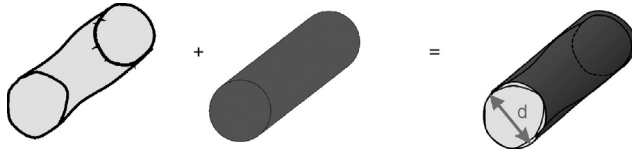
**Fig. 29.7** Extraction.

**Fig. 29.8** – in practice it is generally found that in addition to the extraction operation, some filtering or smoothing of the extracted data is necessary, in order to remove any unwanted detail. This operation is known as *filtering*.



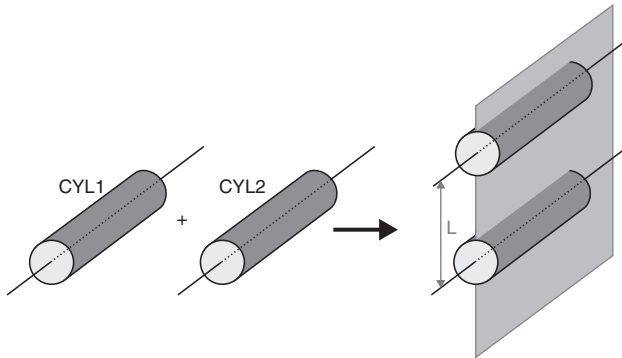
**Fig. 29.8** Filtration.

**Fig. 29.9** illustrates the term known as *association*, this being the operation resulting in a perfect form associated to the extracted surface in accordance with specified convention, which may include the method of least squares, minimum zone, maximum inscribing and minimum circumscribing.



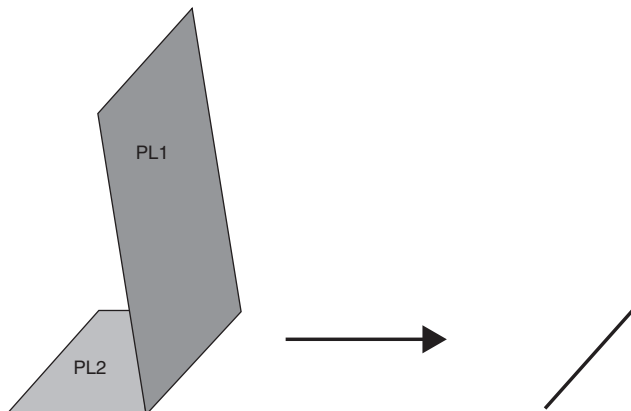
**Fig. 29.9** Association.

**Fig. 29.10** illustrates the term known as *collection*, this being the operation when there is a need to consider more than one feature together, i.e. such as the collection of data, relating to a group or pattern of holes.



**Fig. 29.10** Collection.

**Fig. 29.11** illustrates the term known as *construction*, this being the operation used to determine the tolerated feature, when tolerances are applied to other features which are dependent on, or resultants of, other features. Hence the operation used to build ideal features from other ideal features with constraints is known by the term *construction*.



**Fig. 29.11** Construction.

## **Advantages of the Duality Principle**

It is a critical factor of the synergy between the disciplines of the design, manufacturing, and verification.

It provides a unified system, a common language, and a common understanding.

It removes the option of informal communication and understanding that so often exists between the design, manufacture and verification factions, in house and/or between different manufacturing plants, and sub-contractors.

# Differences between American ASME Y 14.5M geometric dimensioning and tolerancing (GD&T) and ISO/BS 8888 geometrical tolerancing standards

This chapter aims to highlight, identify and analyze the differences between the ASME Y 14.5M and ISO/BS 8888 systems. It makes no claim as to which might be the most appropriate for any specific application. Some of these differences are of a smaller nature, and as such are self-evident, while others are not, and involve indications which are interpreted differently by users of the two different systems, giving rise to significant differences of the intended design specification. All geometric controls included throughout this manual are to the ISO/BS 8888 Standards.

Differences between ASME Y 14.5 and ISO Standards relating to units of physical quantities, tenets/principles, general/basic drawing rules and terminology are detailed in [Table 30.1](#).

## Applicability of standards

The rules under which any drawing is produced must be indicated within the framework of the drawing, i.e. ISO or ANSI Y 14.5M.


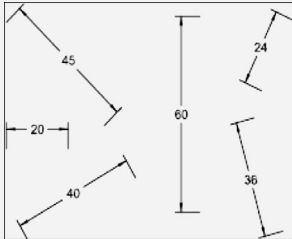
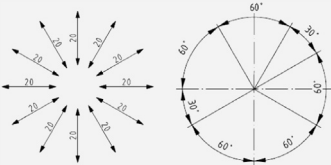
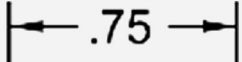

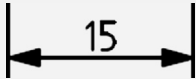
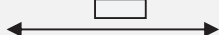
If a provision from ASME Y 14.5M were needed to be invoked on a drawing conforming to ISO rules, the relevant ASME Y 14.5M cross-reference must be specifically identified at the point of application.

**Table 30.1** Differences between ASME Y 14.5 and ISO standards.

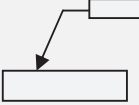
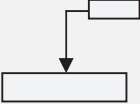
	ASME Y 14.5	ISO/BS 8888
Units/ physical quantities	Metric or US customary (inch) and micro inch or micrometre for surface finish.	Metric system unit is millimetre by default for dimensional and geometric specification and micrometre for surface texture.

*Continued*

**Table 30.1** Differences between ASME Y 14.5 and ISO standards.—cont'd

	ASME Y 14.5	ISO/BS 8888
Tenets/ principles	Envelope principle for features of size.  Simultaneous requirement for patterns of features.  Independency principle invoked by the independency modifier.  All dimensions and tolerances apply in the free state.  Characteristics not defined because the operations are not defined.	Evoked by E in a circle symbol.    Evoked by addition of "CZ" symbol in the tolerance frame.  Independency principle default applies to individual features and collections of features.  Consider the rigidity of the workpiece by default.  Characteristics are defined from geometrical features.
General basic drawing rules	Reading direction horizontal from the bottom of the page for all dimensions.  	Values on oblique and angular dimensions shall be oriented as shown below.  
General basic drawing rules	Preferably, dimension lines should be broken for insertion of numerals. Where horizontal dimension lines are not broken, numerals are placed above and parallel to the dimension lines.    Preferably, dimension line should be broken for insertion of basic dimension symbol with value within the symbol.  	Dimensional values shall be placed parallel to their dimension line and near the middle of and slightly above that line.    TEDs are placed parallel to their dimension line and near the middle of and slightly above that line.  
	Actual mating envelope.	Derived feature.

**Table 30.1** Differences between ASME Y 14.5 and ISO standards.—cont'd

	ASME Y 14.5	ISO/BS 8888
Terminology & tolerancing	Third angle projection is the default with arrow method optional.	First angle projection is the default with arrow method optional.
	Decimal separator is a point by default.	Decimal separator is a comma by default.
	Tolerance zone is always normal to the surface, or in the case of position in two directions, the width and height of the tolerance zone is indicated by arrows.	Direction of the arrows from the tolerance frame sometimes gives the direction of the tolerance zone.
		
	Boundary, inner	Least material virtual condition (LMVC) for external features. Maximum material virtual condition (MMVC) for internal features
	Boundary, outer	Least material virtual condition (LMVC) for internal features. Maximum material virtual condition (MMVC) for external features
	Circularity (roundness)	Roundness
	Co-planarity	Co-planarity not defined similar to flatness
	Datum axis	Datum
	Datum feature simulator	Associated feature to the datum feature
Datum feature simulator (theoretical)	Associated feature to the datum feature	
Datum feature simulator (physical)	Associated feature to the datum feature	
Datum reference frame	Datum system — three-plane-datum system	
Datum, simulated	The situation feature of the associated feature to the datum feature	

*Continued*

**Table 30.1** Differences between ASME Y 14.5 and ISO standards.—cont'd

	<b>ASME Y 14.5</b>	<b>ISO/BS 8888</b>
Terminology & tolerancing	Diameter, average	Median range diameter or other kinds of diameter and sizes
	Dimension, basic	Theoretically exact dimension (TED)
	Dimension, reference	Auxiliary dimension
	Envelope, actual mating	No equivalent term
	Unrelated actual mating envelope	Associated feature
	Associated feature	
	Related actual mating envelope	No equivalent term
	Envelope, actual minimum material	No equivalent term
	Unrelated actual minimum material envelope	No equivalent term
	Related actual minimum material envelope	No equivalent term
	Feature	Feature Real feature of a workpiece Real (integral) feature
	Feature axis	Derived feature
	Feature, center plane of	Derived feature
	Derived medial plane	Nominal derived feature Extracted derived feature Extracted median surface
	Derived medial line	Nominal derived feature Extracted derived feature Extracted median line of a cylinder Extracted median line of a cone
	Regular feature of size	Feature of size
	Irregular feature of size	No equivalent term
	Feature relating tolerance zone framework (FRTZF)	No equivalent term
	Free state variation	No equivalent term
	Least material limit of size (used, but not defined)	Least material size (LMS)
Maximum material limit of size (used, but not defined)	Maximum material size (MMS)	

**Table 30.1** Differences between ASME Y 14.5 and ISO standards.—cont'd

	ASME Y 14.5	ISO/BS 8888
	Non-uniform tolerance zone	No equivalent term
	Pattern	No equivalent term
	Pattern locating tolerance zone framework (PLTZF)	No equivalent term
	Plane, tangent	No equivalent term
	Profile	No equivalent term
	Profile of a line	Profile of any line
	Profile of a surface	Profile of any surface
	Regardless of feature size (RFS)	No equivalent term
	Regardless of material boundary (RMB)	No equivalent term
	No equivalent term	Reciprocity requirement
	Restraint	The term <i>restraint</i> is described but not defined in ISO standards
	Run out	No equivalent term
	Simultaneous requirement	The term <i>simultaneous requirement</i> is described but not defined in ISO standards. A simultaneous requirement is achieved by the use of the 'CZ' symbol
	Size, actual local	Local size of an extracted cylinder Local diameter of an extracted cylinder Local size of two parallel extracted surfaces
	Statistical tolerancing	This subject is not addressed in ISO standards
	Tolerance, bilateral	No equivalent term
	Tolerance, geometrical	Geometrical tolerance
	Tolerance, unilateral	No equivalent term
	True position	Position

Continued



**Table 30.1** Differences between ASME Y 14.5 and ISO standards.—cont'd

	ASME Y 14.5	ISO/BS 8888
Terminology & tolerancing	True profile Uniform tolerance zone Virtual condition	No equivalent term No equivalent term Maximum material virtual condition (MMVC) Least material virtual condition (LMVC)

## Symbology

ASME Y 14.5 specifies in addition to or deviating from ISO 1101 the symbols shown in [Table 30.2](#).

**Table 30.2** Additional symbols found in ASME Y14-5M.

Symbol	Designation	Interpretation
	Tangent	Symbol placed within the tolerance frame indicating a tolerance applies to the contacting tangential element.
CR	Controlled radius	Symbol placed before the toleranced radius dimension. The tolerance zone is defined by two arcs (the minimum and maximum radii) that are tangential to the adjacent surfaces. The part contour within the crescent-shaped tolerance zone must be a fair curve without reversals with all points on the radii being within the tolerance zone.
	Statistical tolerancing	Symbol placed after a toleranced dimension indicating the assigning of tolerances to related components of an assembly on the basis of sound statistics (such as the assembly tolerance is equal to the square root of the sum of the squares of the individual tolerances).

## Specification of datums

While the general understanding that a datum is basically a 'good starting surface or point' is not wrong, the advancement and availability of today's manufacturing technology has created many more options of specific applications of datums that

may be required. ISO 5459 and ASME Y 14.5M Standards comprehensively define these conceptual options together by their respective rules. These two set of rules can lead to substantially different conclusions. A brief explanation appears below.

Keeping in line with these developments of modern techniques, ISO Standards give a wide range of different, sophisticated, practical conceptual terms and procedures for the various types of datums which may be specified on a drawing. Basically, where a specified datum feature has a form that allows the workpiece to 'rock' within itself, the ISO rule is to 'equalize' the rock, in order to establish an 'average' position and orientation to be used as the intended datum.

ASME Y 14.5M specifies the concept of 'candidate datums' which allows every position that an unstable datum can rock to (with some limitations) to be a valid 'candidate datum'. A set of candidate datum reference frames can be derived for each set of requirements that are referenced to the same datum system, using the same precedence and the same material conditions. These sets of requirements are, by default, evaluated simultaneously to each candidate datum reference frame. If there is a candidate datum reference frame where all the requirements are fulfilled, the workpiece is acceptable with regard to the requirements.

In general, the ASME Y 14.5M system accepts more workpieces as the form error of the datum feature increases. However, some workpieces accepted under the applied ISO rules can be rejected upon application of the Y 14.5M rules, so assumptions should not be made.

## **Exclusion of surface texture**

The ISO Standards do not currently state whether surface texture should be included or excluded within or from a specified geometric control, when evaluated. (However, the application of BS 8888 requires that surface texture is excluded by the use of appropriate filtering techniques.)

ASME Y 14.5M states that 'all requirements apply after application of the smoothing functions'. In other words, surface texture shall be disregarded when evaluating workpieces using ASME Y 14.5M and thus this is similar to the dictates of BB 8888.

## **Tolerancing principle**

The ASME Y 14.5M interprets size tolerances using the 'Principle of Dependency of size and form' in the same terms as the ISO Envelope Principle (Taylor Principle), i.e. when only a size tolerance is quoted, the form of a workpiece is always within its maximum size when at maximum material condition (MMC). This is known as

*Rule 1* and stated in the ASME Y 14.5M Standard. It was realized that this overall rule was not practical in all cases, and some exceptions to this rule are as follows:

- (a) It does not apply to stock materials (bar stock, sheet, tubing, etc.)
- (b) It does not apply to flexible parts, subject to free-state variation in the unstrained condition.
- (c) It does not apply to features of size which have a straightness tolerance applied to their axes or median plane.
- (d) It may be overruled where a feature of size has a specified relationship between size and a geometric control, for example the use of  $\textcircled{M}$  or  $\textcircled{L}$  in the tolerance frame.
- (e) It may be overruled with a statement such as 'PERFECT FORM AT MMC NOT REQUIRED' placed by a feature of size tolerance.

ISO promotes (ISO 8015) the 'Principle of Independency' which states: 'Each specified dimensional or geometrical requirement on a drawing shall be met independently, unless a particular relationship is specified.' i.e. Maximum or Least Material Condition

$\textcircled{M}$   $\textcircled{L}$ , or the envelope principle (the Taylor principle)  $\textcircled{E}$ .

This means that local two-point measurements control the linear dimensional tolerances only, and not the form deviations of the feature.

## Features of size

Table 30.3 lists features of size recognized by each Standard.




**Table 30.3** Features of size.

ISO	ASME Y14.5M
Cylindrical surfaces (see below)	Cylindrical surfaces (see below)
Spherical surfaces (see below)	Spherical surfaces (see below)
Two parallel, opposed surfaces	Two parallel, opposed surfaces
A cone	Circular element
A wedge	Two opposed elements (such as the radiused ends of a slot)

180° rule: it is generally agreed by ISO and ASME that spherical and circular surfaces can only be considered a feature of size when the included angle is greater than 180°.



Tolerance Characteristics (Table 30.4).

**Table 30.4** Comparison of tolerance characteristics.

Tolerance	BS 8888 and ISOs	ASME Y 14.5:1994
Positional 	Positional tolerance can be used to control the location of features of size and also points, lines and flat planes.	The positional tolerance is <i>only</i> used with features of size. ASME Y 14.5 recommends the use of profile of a surface to control a flat planar surface.
Concentricity/ coaxiality 	<p>These characteristics have the same symbol even though they distinctively relate to different characteristics, with the term <i>concentricity</i> frequently and mistakenly confused with <i>coaxiality</i>, and vice versa.</p> <p>The ISO definition describes concentricity as the situation whereby the center point of a feature is located on a datum point or axis. Coaxiality is described as the situation where an axis of a feature is aligned to a datum axis. Concentricity/coaxiality tolerances can be replaced by using a positional tolerance to provide an identical control. Concentricity/coaxiality tolerances can be used with the maximum and least material condition modifiers.</p>	<p>Known only as <i>concentricity</i> tolerance. It is defined as the condition whereby the median points of all diametrically opposed elements of a figure of revolution are congruent with the axis or center point of a datum feature.</p> <p>The standard states that concentricity cannot be used with the maximum and least material modifiers.</p>
Symmetry 	<p>ISO considers this as a special case of the positional tolerance, which can be used to control the location of an axis or median plane of a feature of size in relation to a datum axis.</p> <p>Symmetry tolerances can be replaced by using a positional tolerance to provide an identical control.</p> <p>Symmetry tolerance can be used with maximum and least condition modifiers</p>	<p>Symmetry is defined as the condition where the median points of all opposed or corresponding located elements of two or more feature surfaces are congruent with the axis or center plane of a datum feature. It is also stated that symmetry cannot be used with the maximum or least condition modifiers.</p>

*Continued*

**Table 30.4** Comparison of tolerance characteristics.—cont'd

Tolerance	BS 8888 and ISOs	ASME Y 14.5:1994
<p data-bbox="119 274 229 357">Profile of a line and surface</p> 	<p data-bbox="284 274 622 505">These tolerance zones are generated by placing a theoretical circle or sphere, with a diameter corresponding to the size of the tolerance, on every point of the theoretically exact profile (or surface) to generate the boundary limits.</p> <p data-bbox="284 510 622 678">Where the theoretically exact profile (or surface) contains sharp corners (or edges) the tolerance zone boundary external to the corners (or edges) is radiused.</p> <p data-bbox="284 683 622 1060">A profile tolerance when applied to a collection of connecting surfaces using the 'between' or 'all around' symbols (see Fig. 22.1C) considers the surfaces to be a single compound feature with a single tolerance zone. If the compound feature contains sharp corners, the tolerance zone for these will be rounded because of the use of a circle or sphere to define the tolerance zone (as above)</p> <p data-bbox="284 1065 622 1208">Unilateral and bilateral tolerances can be identified by using the UZ modifier which applies to the offset to the center of the tolerance zone</p>	<p data-bbox="649 274 988 418">These tolerance zones are generated by a vector offset from the theoretically exact profile (or surface) to generate the boundary limits.</p> <p data-bbox="649 423 988 591">Where the theoretically exact profile (or surface) contains sharp corners or (edges) the tolerance zone boundary is extended to give a sharp corner (or edge).</p> <p data-bbox="649 597 988 913">A profile tolerance when applied to a collection of connecting surfaces using the 'between' or 'all around' symbols (see Fig. 22.1C) considers the surfaces to be a single compound feature with a single tolerance zone. If the compound feature contains sharp corners, the tolerance zone is extended to give a sharp corner (as above).</p> <p data-bbox="649 918 988 1086">Unilateral and bilateral tolerances can be identified by using the Ⓢ modifier which applies to the offset to the outer limit of the tolerance zone from the true profile.</p>
<p data-bbox="119 1222 225 1251">Roundness</p> 	<p data-bbox="284 1222 622 1277">ISO uses the term <i>roundness</i> for this form tolerance.</p>	<p data-bbox="649 1222 988 1277">ASME uses the term <i>circularity</i> for this form tolerance.</p>

A cam is generally a disc or a cylinder mounted on a rotating shaft, and it gives a special motion to a *follower*, by direct contact. The cam profile is determined by the required follower motion and the design of the type of follower.

The motions of cams can be considered to some extent as alternatives to motions obtained from linkages, but cams are generally easier to design, and the resulting actions can be accurately predicted. If, for example, a follower is required to remain stationary, then this is achieved by a concentric circular arc on the cam. For a specified velocity or acceleration, the displacement of the follower can easily be calculated, but these motions are very difficult to arrange precisely with linkages.

Specialist cam-manufacturers computerize design data and, for a given requirement, would provide a read-out with cam dimensions for each degree, minute, and second of camshaft rotation.

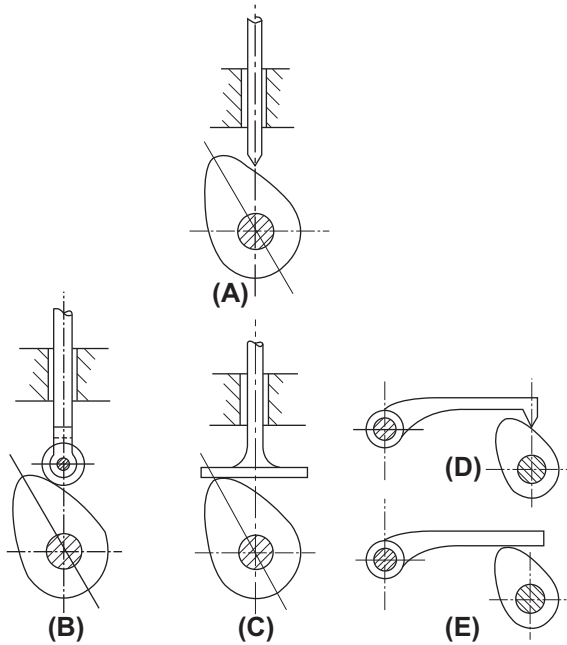
When used in high-speed machinery, cams may require to be balanced, and this becomes easier to perform if the cam is basically as small as possible. A well-designed cam system will involve not only consideration of velocity and acceleration but also the effects of out-of-balance forces, and vibrations. Suitable materials must be selected to withstand wear and the effect of surface stresses.

Probably the most widely used cam is the *plate cam*, with its contour around the circumference. The line of action of the follower is usually either vertical or parallel to the camshaft, and Fig. 31.1 shows several examples.

Examples are given later of a *cylindrical* or *drum cam*, where the cam groove is machined around the circumference, and also a *face cam*, where the cam groove is machined on a flat surface.

## Cam followers

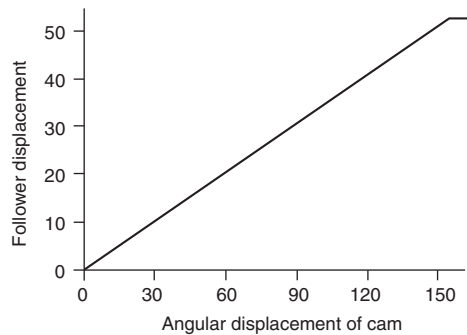
Various types of cam followers are shown in Fig. 31.1. Knife-edge followers are restricted to use with slow-moving mechanisms, due to their rapid rates of wear. Improved stability can be obtained from the roller follower, and increased surface area in contact with the cam can be obtained from the flat and mushroom types of follower. The roller follower is the most expensive type, but is ideally suited to high speeds and applications where heat and wear are factors.



**Fig. 31.1** Plate cams. (A) Plate cam with knife-edge follower. (B) Plate cam with roller follower. (C) Plate cam with flat follower. (D) Plate cam with oscillating knife-edge follower. (E) Plate cam with oscillating flat follower.

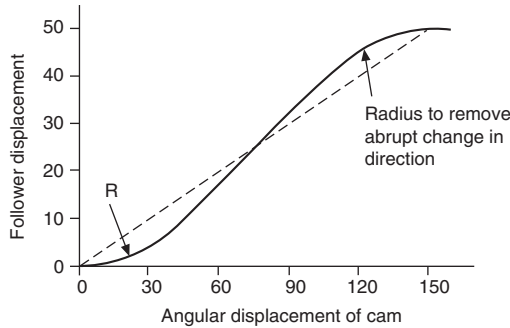
## Cam follower motions

1. *Uniform velocity*: This motion is used where the follower is required to rise or fall at a constant speed, and is often referred to as straight-line motion. Part of a uniform-velocity cam graph is shown in [Fig. 31.2](#).



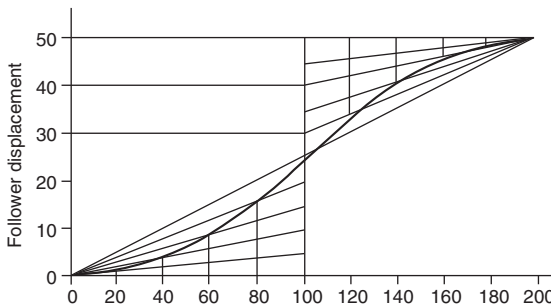
**Fig. 31.2** Uniform velocity cam graph.

1. Abrupt changes in velocity with high-speed cams result in large accelerations and cause the followers to jerk or chatter. To reduce the shock on the follower, the cam graph can be modified as indicated in Fig. 31.3 by adding radii to remove the sharp corners. However, this action results in an increase in the average rate of rise or fall of the follower.



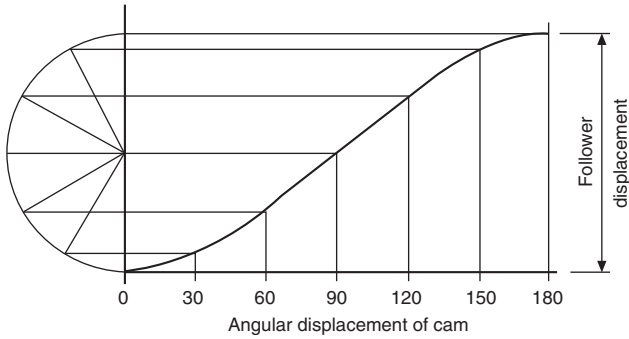
**Fig. 31.3** Modified cam graph to remove abrupt change in direction.

2. *Uniform acceleration and retardation motion* is shown in Fig. 31.4. The graphs for both parts of the motion are parabolic. The construction for the parabola involves dividing the cam-displacement angle into a convenient number of parts, and the follower displacement into the same number of parts. Radial lines are drawn from the start position to each of the follower division lines, and the parabola is obtained by drawing a line through successive intersections. The uniform-retardation parabola is constructed in a similar manner, but in the reverse position.



**Fig. 31.4** Uniform acceleration and retardation motion cam graph.

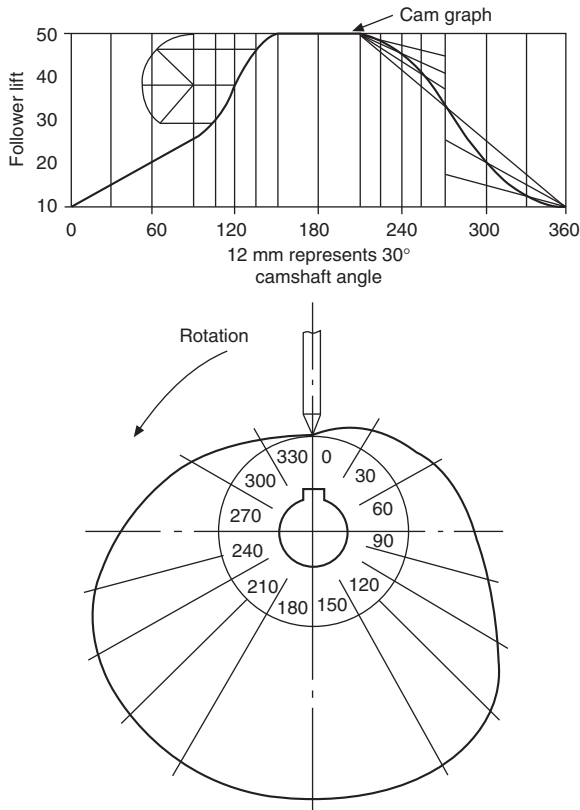
3. *Simple harmonic motion* is shown in Fig. 31.5 where the graph is a sine curve. The construction involves drawing a semi-circle and dividing it into the same number of parts as the cam-displacement angle. The diameter of the semi-circle is equal to the rise or fall of the follower. The graph passes through successive intersections as indicated.



**Fig. 31.5** Simple harmonic motion cam graph.

The application of the various motions to different combinations of cams and followers is shown by the following practical example.

### Case 1 (Fig. 31.6)



**Fig. 31.6** Plate cam graph and profile with point follower.

*Cam specification:*

- Plate cam, rotating anticlockwise. Point follower.  
 Least radius of cam, 30 mm. Camshaft diameter, 20 mm.  
 $0^\circ$ – $90^\circ$ , follower rises 20 mm with uniform velocity.  
 $90^\circ$ – $150^\circ$ , follower rises 30 mm with simple harmonic motion.  
 $150^\circ$ – $210^\circ$ , dwell period.  
 $210^\circ$ – $270^\circ$ , follower falls 20 mm with uniform acceleration.  
 $270^\circ$ – $360^\circ$ , follower falls 30 mm with uniform retardation.

1. Draw the graph as shown. Exact dimensions are used for the  $Y$  axis, where the follower lift is plotted. The  $X$  axis has been drawn to scale, where 12 mm represents  $30^\circ$  of shaft rotation.
2. To plot the cam, draw a 20 mm diameter circle to represent the bore for the camshaft, and another circle 30 mm in radius to represent the base circle, or the least radius of the cam, i.e. the nearest the follower approaches to the center of rotation.
3. Draw radial lines  $30^\circ$  apart from the cam center, and number them in the reverse direction to the cam rotation.
4. Plot the  $Y$  ordinates from the cam graph along each of the radial lines in turn, measuring from the base circle. Where rapid changes in direction occur, or where there is uncertainty regarding the position of the profile, more points can be plotted at  $10^\circ$  or  $15^\circ$  intervals.
5. Draw the best curve through the points to give the required cam profile.

*Note:* The user will require to know where the cam program commences, and the zero can be conveniently established on the same center line as the shaft keyway. Alternatively, a timing hole can be drilled on the plate, or a mark may be engraved on the plate surface. In cases where the cam can be fitted back to front, the direction or rotation should also be clearly marked.

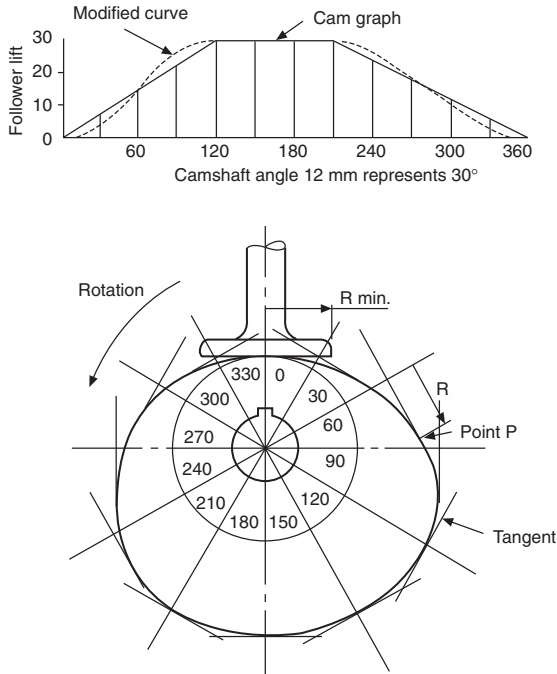
## Case 2 (Fig. 31.7)

*Cam specification:*

- Plate cam, rotating anticlockwise. Flat follower. Least distance from follower to cam center, 30 mm. Camshaft diameter, 20 mm.  
 $0^\circ$ – $120^\circ$ , follower rises 30 mm with uniform velocity (modified).  
 $120^\circ$ – $210^\circ$ , dwell period.  
 $220^\circ$ – $360^\circ$ , follower falls 30 mm with uniform velocity (modified).

1. Draw the cam graph as shown, and modify the curve to remove the sharp corners. Note that in practice the size of the radius frequently used here varies between one-third and the full lift of the follower for the uniform-velocity part of the graph; the actual value depends on the rate of velocity and the speed of rotation. This type of motion is not desirable for high speeds.
2. Draw the base circle as before 30 mm radius; divide it into  $30^\circ$  intervals, and number them in the reverse order to the direction of rotation.
3. Plot the  $Y$  ordinates from the graph, radially from the base circle along each  $30^\circ$  interval line. Draw a tangent at each of the plotted points, as shown, and draw the best curve to touch the tangents. The tangents represent the face of the flat follower in each position.
4. Check the point of contact between the curve and each tangent and its distance from the radial line. Mark the position of the widest point of contact.

In the illustration given, point  $P$  appears to be the greatest distance, and hence the follower will require to be at least  $R$  in radius to keep in contact with the cam profile at



**Fig. 31.7** Plate cam graph and profile with flat follower.

this point. Note also that a flat follower can be used only where the cam profile is always convex.

Although the axis of the follower and the face are at  $90^\circ$  in this example, other angles are in common use.

### Case 3 (Fig. 31.8)

*Cam specification:*

Plate cam, rotating clockwise. 20 mm diameter roller follower.

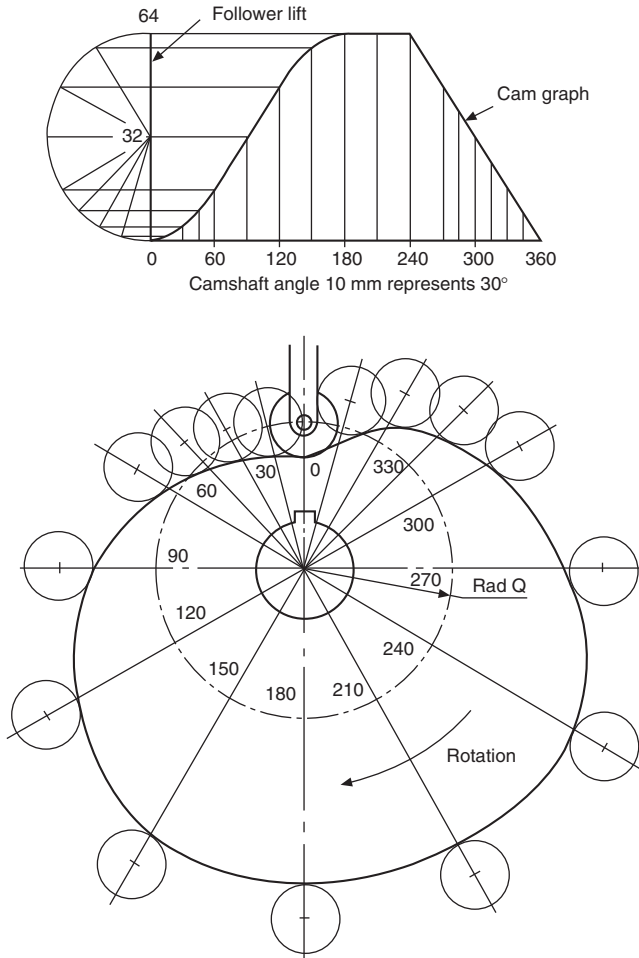
30 mm diameter camshaft. Least radius of cam, 35 mm.

$0^\circ$ – $180^\circ$ , rise 64 mm with simple harmonic motion.

$180^\circ$ – $240^\circ$ , dwell period.

$240^\circ$ – $360^\circ$ , fall 64 mm with uniform velocity.

1. Draw the cam graph as shown.
2. Draw a circle (shown as RAD Q) equal to the least radius of the cam plus the radius of the roller, and divide it into  $30^\circ$  divisions. Mark the camshaft angles in the anticlockwise direction.
3. Along each radial line plot the Y ordinates from the graph, and at each point draw a 20 mm circle to represent the roller.
4. Draw the best profile for the cam so that the cam touches the rollers tangentially, as shown.



**Fig. 31.8** Plate cam graph and profile with roller follower.

### Case 4 (Fig. 31.9)

#### *Cam specification:*

Plate cam, rotating clockwise. 20 mm diameter roller follower set 20 mm to the right of the center line for the camshaft. Least distance from the roller center to the camshaft center line, 50 mm. 25 mm diameter camshaft.

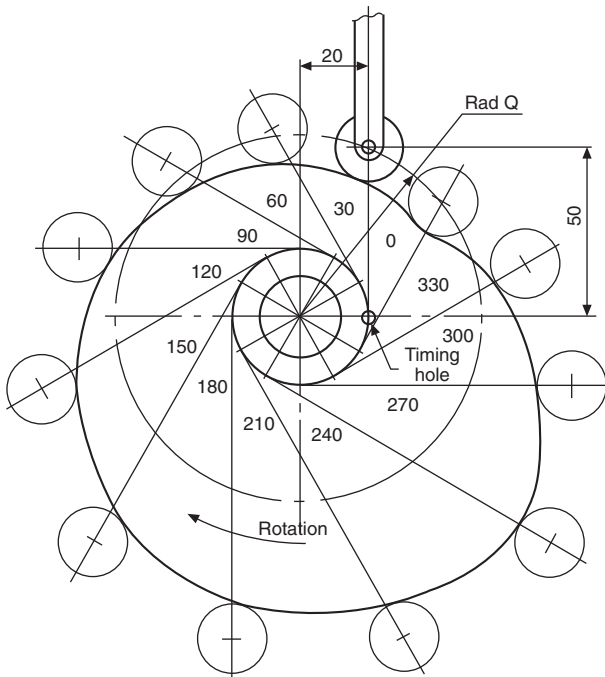
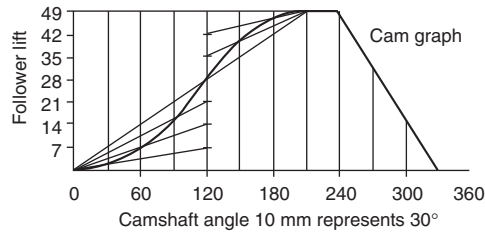
0°–120°, follower rises 28 mm with uniform acceleration.

120°–210°, follower rises 21 mm with uniform retardation.

210°–240°, dwell period.

240°–330°, follower falls 49 mm with uniform velocity.

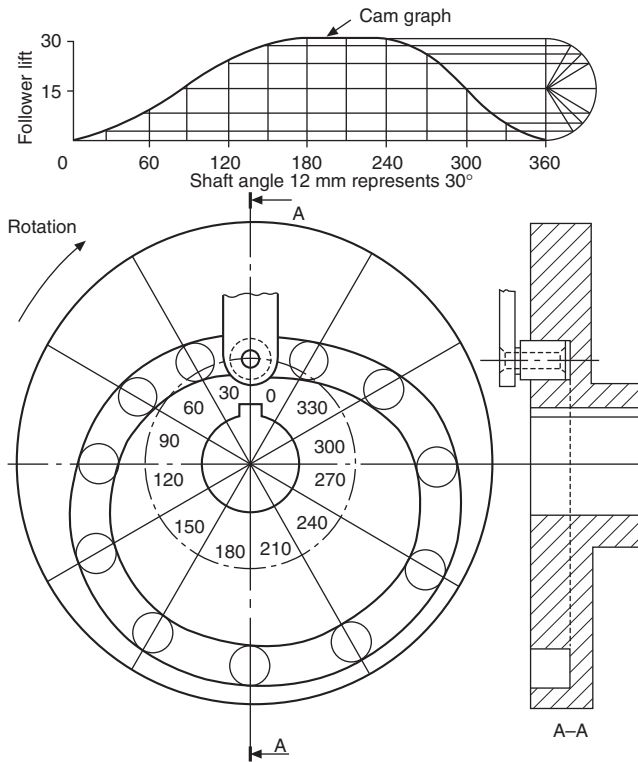
330°–360°, dwell period.



**Fig. 31.9** Plate cam graph and profile with roller follower.

1. Draw the cam graph as shown.
2. Draw a 20 mm radius circle, and divide it into  $30^\circ$  divisions as shown.
3. Where the  $30^\circ$  lines touch the circumference of the 20 mm circle, draw tangents at these points.
4. Draw a circle of radius  $Q$ , as shown, from the center of the camshaft to the center of the roller follower. This circle is the base circle.
5. From the base circle, mark lengths equal to the lengths of the  $Y$  ordinates from the graph, and at each position draw a 20 mm diameter circle for the roller follower.
6. Draw the best profile for the cam so that the cam touches the rollers tangentially, as in the last example.

## Case 5 (Fig. 31.10)



**Fig. 31.10** Face cam graph and profile with roller follower.

### *Cam specification:*

Face cam, rotating clockwise. 12 mm diameter roller follower. Least radius of cam, 26 mm. Camshaft diameter, 30 mm.

0°–180°, follower rises 30 mm with simple harmonic motion.

180°–240°, dwell period.

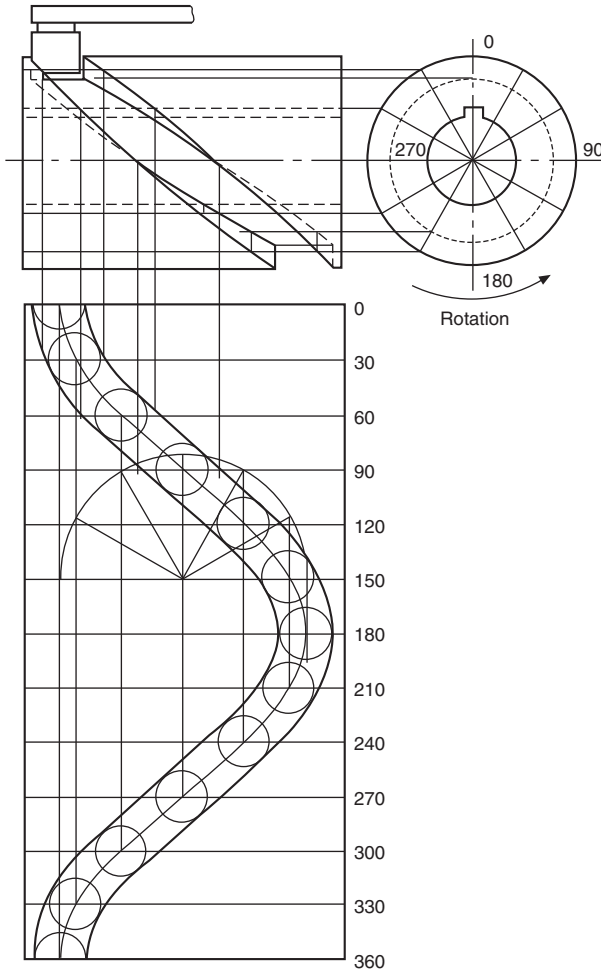
240°–360°, follower falls 30 mm with simple harmonic motion.

1. Draw the cam graph, but note that for the first part of the motion the semi-circle is divided into six parts, and that for the second part it is divided into four parts.
2. Draw a base circle 32 mm radius, and divide into 30° intervals.
3. From each of the base-circle points, plot the lengths of the  $Y$  ordinates. Draw a circle at each point for the roller follower.
4. Draw a curve on the inside and the outside, tangentially touching the rollers, for the cam track.

The drawing shows the completed cam together with a section through the vertical center line.

Note that the follower runs in a track in this example. In the previous cases, a spring or some resistance is required to keep the follower in contact with the cam profile at all times.

### Case 6 (Fig. 31.11)



**Fig. 31.11** Cylindrical cam graph and profile with roller follower.

#### *Cam specification:*

Cylindrical cam, rotating anticlockwise, operating a roller follower, 14 mm diameter. Cam cylinder, 60 mm diameter. Depth of groove, 7 mm.

0°–180°, follower moves 70 mm to the right with simple harmonic motion.

$180^\circ$ – $360^\circ$ , follower moves 70 mm to the left with simple harmonic motion.

1. Set out the cylinder blank and the end elevation as shown.
2. Divide the end elevation into  $30^\circ$  divisions.
3. Underneath the front elevation, draw a development of the cylindrical cam surface, and on this surface draw the cam graph.
4. Using the cam graph as the center line for each position of the roller, draw 14 mm diameter circles as shown.
5. Draw the cam track with the sides tangential to the rollers.
6. Plot the track on the surface of the cylinder by projecting the sides of the track in the plan view up to the front elevation. Note that the projection lines for this operation do not come from the circles in the plan, except at each end of the track.
7. The dotted line in the end elevation indicates the depth of the track.
8. Plot the depth of the track in the front elevation from the end elevation, as shown. Join the plotted points to complete the front elevation.

Note that, although the roller shown is parallel, tapered rollers are often used, since points on the outside of the cylinder travel at a greater linear speed than points at the bottom of the groove, and a parallel roller follower tends to skid.

## Dimensioning cams

Fig. 31.12 shows a cam in contact with a roller follower; note that the point of contact between the cam and the roller is at A, on a line which joins the centers of the two arcs. To dimension a cam, the easiest method of presenting the data is to provide it in tabular form which relates the angular displacement  $\theta$  of the cam with the radial displacement  $R$  of the follower. The cam could then be cut on a milling machine using these point settings. For accurate master cams, these settings may be required at half- or one-degree intervals.

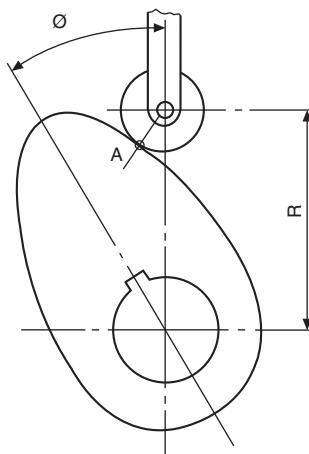
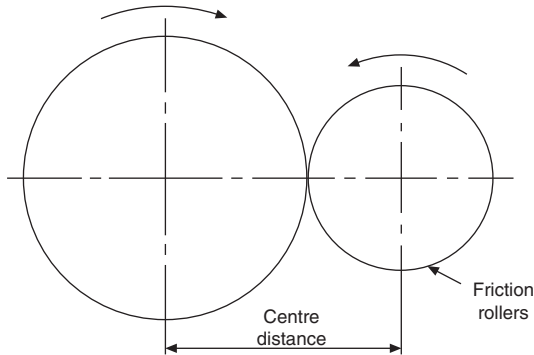


Fig. 31.12 Elements required to dimension a cam.

## Spur gears

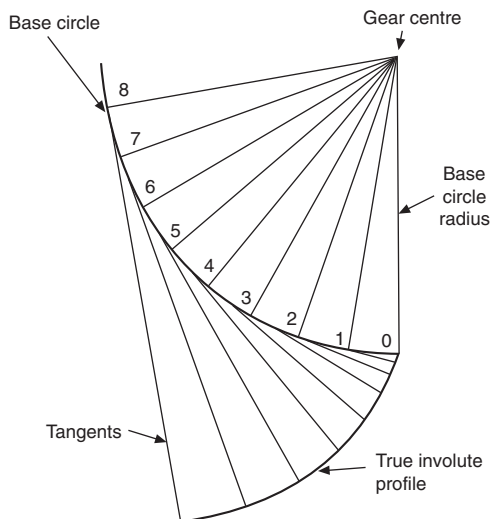
The characteristic feature of spur gears is that their axes are parallel. The gear teeth are positioned around the circumference of the pitch circles, which are equivalent to the circumferences of the friction rollers in Fig. 31.13.



**Fig. 31.13** Spur gear characteristics.

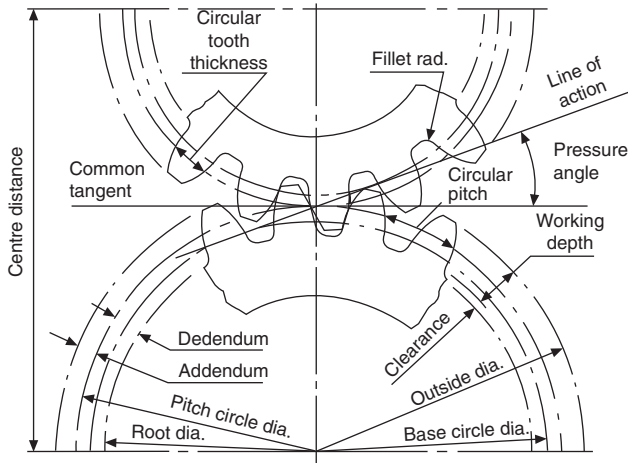
The teeth are of *involute* form, the involute being described as the locus traced by a point on a taut string as it unwinds from a circle, known as the base circle. For an involute rack, the base circle radius is of infinite length, and the tooth flank is therefore straight.

The construction for the involute profile is shown in Fig. 31.14. The application of this profile to an engineering drawing of a gear tooth can be rather a tedious exercise, and approximate methods are used, as described later.



**Fig. 31.14** Involute construction. The distance along the tangent from each point is equal to the distance around the circumference from point 0.

## Spur-gear terms (Fig. 31.15)



**Fig. 31.15** Spur-gear terms.

The *gear ratio* is the ratio of the number of teeth in the gear to the number of teeth in the pinion, the pinion being the smaller of the two gears in mesh.

The *pitch-circle diameters* of a pair of gears are the diameters of cylinders co-axial with the gears which will roll together without slip. The pitch circles are imaginary friction discs, and they touch at the *pitch point*.

The *base circle* is the circle from which the involute is generated.

The *root diameter* is the diameter at the base of the tooth.

The *center distance* is the sum of the pitch-circle radii of the two gears in mesh.

The *addendum* is the radial depth of the tooth from the pitch circle to the tooth tip.

The *dedendum* is the radial depth of the tooth from the pitch circle to the root of the tooth.

The *clearance* is the algebraic difference between the addendum and the dedendum.

The *whole depth* of the tooth is the sum of the addendum and the dedendum.

The *circular pitch* is the distance from a point on one tooth to the corresponding point on the next tooth, measured round the pitch-circle circumference.

The *tooth width* is the length of arc from one side of the tooth to the other, measured round the pitch-circle circumference.

The *module* is the pitch-circle diameter divided by the number of teeth.

The *diametral pitch* is the reciprocal of the module, i.e. the number of teeth divided by the pitch-circle diameter.

The *line of action* is the common tangent to the base circles, and the *path of contact* is that part of the line of action where contact takes place between the teeth.

The *pressure angle* is the angle formed between the common tangent and the line of action.

The *fillet* is the rounded portion at the bottom of the tooth space.

The various terms are illustrated in [Fig. 31.15](#).

## Involute gear teeth proportions and relationships

$$\text{Module} = \frac{\text{pitch-circle diameter, PCD}}{\text{number of teeth, } T}$$

$$\text{Circular pitch} = \pi \times \text{module}$$

$$\text{Tooth thickness} = \frac{\text{circular pitch}}{2}$$

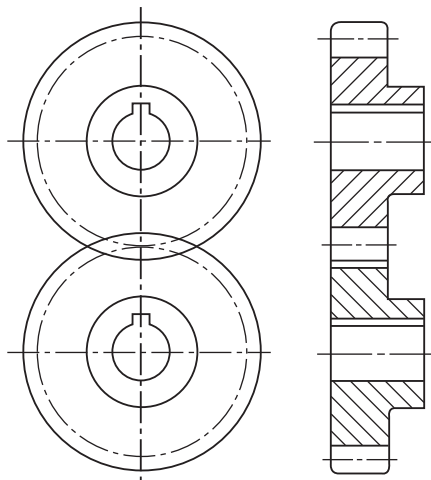
$$\text{Addendum} = \text{Module}$$

$$\text{Clearance} = 0.25 \times \text{module}$$

$$\text{Dedendum} = \text{addendum} + \text{clearance}$$

Involute gears having the same pressure angle and module will mesh together. The British Standard recommendation for pressure angle is  $20^\circ$ .

The conventional representation of gears shown in [Fig. 31.16](#) is limited to drawing the pitch circles and outside diameters in each case. In the sectional end elevation, a section through a tooth space is taken as indicated. This convention is common practice with other types of gears and worms.



**Fig. 31.16** Gear conventions.

## Typical example using professor Unwin's approximate construction

*Gear data:*

Pressure angle,  $20^\circ$ . Module, 12 mm: Number of teeth, 25.

*Gear calculations:*

Pitch – circle diameter = module  $\times$  no. of teeth =  $12 \times 25 = 300$  mm

Addendum = module = 12 mm

Clearance =  $0.25 \times$  module =  $0.25 \times 12 = 3$  mm

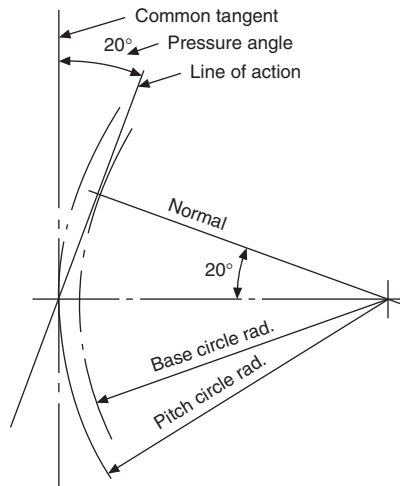
Dedendum = addendum clearance =  $12.3 = 15$  mm

Circularpitch =  $\pi \times$  module =  $\pi \times 12 = 37.68$  mm

Tooth thickness =  $\frac{1}{2}$  (circular pitch) = 18.84 mm

### Stage 1 (Fig. 31.17)

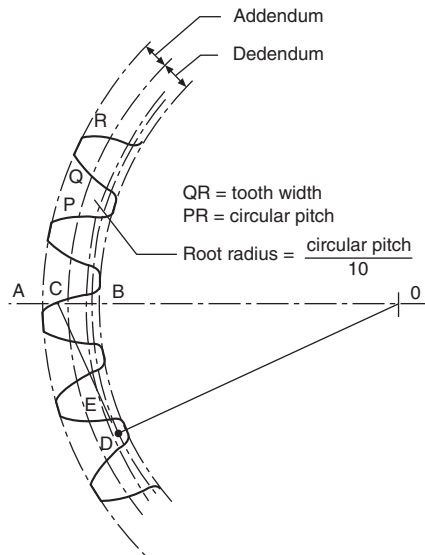
- Draw the pitch circle and the common tangent.
- Mark out the pressure angle and the normal to the line of action.
- Draw the base circle. Note that the length of the normal is the base-circle radius.



**Fig. 31.17** Unwin's construction – stage 1.

### Stage 2 (Fig. 31.18)

- Draw the addendum and dedendum circles. Both addendum and dedendum are measured radially from the pitch circle.
- Mark out point A on the addendum circle and point B on the dedendum circles. Divide AB into three parts so that  $CB = 2AC$ .
- Draw the tangent CD to the base circle. D is the point of tangency. Divide CD into four parts so that  $CE = 3DE$ .
- Draw a circle with center O and radius OE. Use this circle for centers of arcs of radius EC for the flanks of the teeth after marking out the tooth widths and spaces around the pitch-circle circumference.



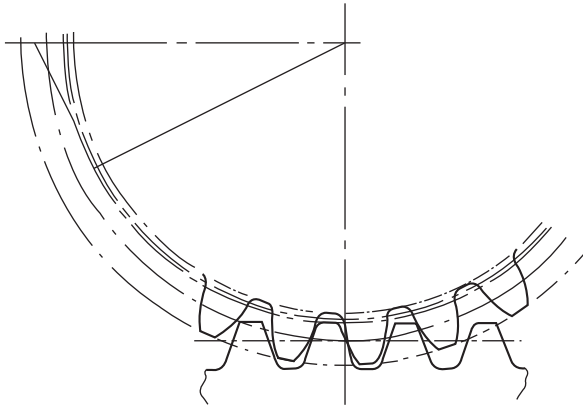
**Fig. 31.18** Unwin's construction – stage 2.

Note that it may be more convenient to establish the length of the radius CE by drawing this part of the construction further round the pitch circle, in a vacant space, if the flank of one tooth, i.e. the pitch point, is required to lie on the line AO.

The construction is repeated in Fig. 31.19 to illustrate an application with a rack and pinion. The pitch line of the rack touches the pitch circle of the gear, and the values of the addendum and dedendum for the rack are the same as those for the meshing gear.

If it is required to use the involute profile instead of the approximate construction, then the involute must be constructed from the base circle as shown in Fig. 31.14. Complete stage 1 and stage 2(a) as already described, and mark off the tooth widths around the pitch circle, commencing at the pitch point. Take a tracing of the involute in soft pencil on transparent tracing paper, together with part of the base circle in order to get the profile correctly oriented on the required drawing. Using a French curve, mark the profile in pencil on either side of the tracing paper, so that, whichever side is used, a pencil impression can be obtained. With care, the profile can now be traced onto the required layout, lining up the base circle and ensuring that the profile of the

tooth flank passes through the tooth widths previously marked out on the pitch circle. The flanks of each tooth will be traced from either side of the drawing paper. Finish off each tooth by adding the root radius.

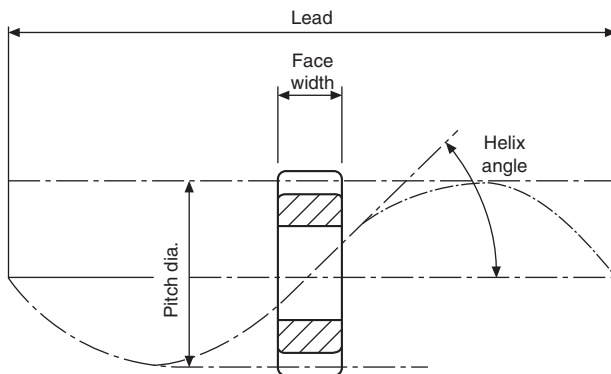


**Fig. 31.19** Unwin's construction applied to a rack and pinion.

## Helical gears

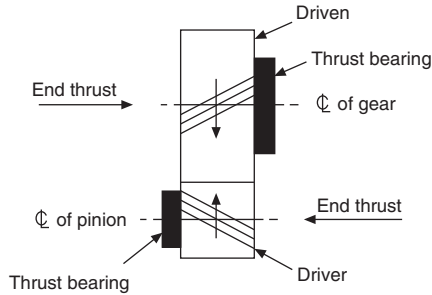
Helical gears have been developed from spur gears, and their teeth lie at an angle to the axis of the shaft. Contact between the teeth in mesh acts along the diagonal face flanks in a progressive manner; at no time is the full length of any one tooth completely engaged. Before contact ceases between one pair of teeth, engagement commences between the following pair. Engagement is therefore continuous, and this fact results in a reduction of the shock which occurs when straight teeth operate under heavy loads. Helical teeth give a smooth, quiet action under heavy loads; backlash is considerably reduced; and, due to the increase in length of the tooth, for the same thickness of gear wheel, the tooth strength is improved.

**Fig. 31.20** illustrates the lead and helix angle applied to a helical gear. For single helical gears, the helix angle is generally  $12^\circ$ – $20^\circ$ .



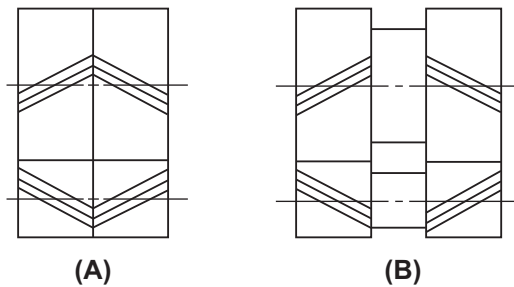
**Fig. 31.20** Lead and helix angle for a helical gear.

Since the teeth lie at an angle, a side or end thrust occurs when two gears are engaged, and this tends to separate the gears. Fig. 31.21 shows two gears on parallel shafts and the position of suitable thrust bearings. Note that the position of the thrust bearings varies with the direction of shaft rotation and the 'hand' of the helix.



**Fig. 31.21** Helical gears fitted with thrust bearings.

In order to eliminate the serious effect of end thrust, pairs of gears may be arranged as shown in Fig. 31.22 where a double helical gear utilizes a left- and a right-hand helix. Instead of using two gears, the two helices may be cut on the same gear blank.

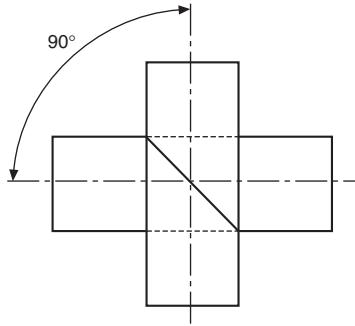


**Fig. 31.22** Double helical gears. (A) On same wheel. (B) On separate wheels.

Where shafts lie parallel to each other, the helix angle is generally  $15^\circ$ – $30^\circ$ . Note that a right-hand helix engages with a left-hand helix, and the hand of the helix must be correctly stated on the drawing. On both gears the helix angle will be the same.

For shafts lying at  $90^\circ$  to each other, both gears will have the same hand of helix (see Fig. 31.23).

Helical gears can be used for shafts which lie at an angle less than  $90^\circ$ , but the hand of helix should be checked with a specialist gear manufacturer. The hand of a helix depends on the helix angle used and the shaft angles required.



**Fig. 31.23** Shafts at 90 degrees.

## Bevel gears

If the action of spur and helical gears can be related to that of rolling cylinders, then the action of bevel gears can be compared to a friction cone drive. Bevel gears are used to connect shafts which lie in the same plane and whose axes intersect. The size of the tooth decreases as it passes from the back edge toward the apex of the pitch cone; hence the cross-section varies along the whole length of the tooth. When viewed on the curved surface which forms part of the back cone, the teeth normally have the same profiles as spur gears. The addendum and dedendum have the same proportions as a spur gear, being measured radially from the pitch circle, parallel to the pitch-cone generator.

Data relating to bevel gear teeth is shown in [Fig. 31.24](#). Note that the crown wheel is a bevel gear where the pitch angle is  $90^\circ$ . Mitre gears are bevel gears where the pitch-cone angle is  $45^\circ$ .

The teeth on a bevel gear may be produced in several different ways, e.g. straight, spiral, helical, or spiraloid. The advantages of spiral bevels over straight bevels lie in quieter running at high speed and greater load-carrying capacity.

The angle between the shafts is generally a right angle, but may be greater or less than  $90^\circ$ , as shown in [Fig. 31.25](#).

Bevel gearing is used extensively in the automotive industry for the differential gearing connecting the drive shaft to the back axle of motor vehicles.

### ***Bevel-gear terms and definitions***

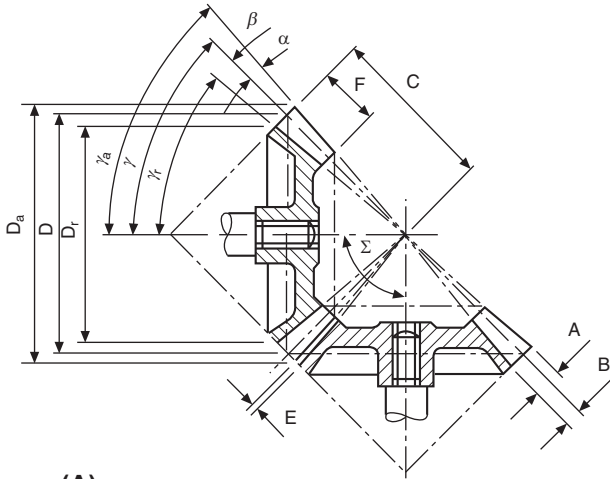
The following are additions to those terms used for spur gears.

*The pitch angle* is the angle between the axis of the gear and the cone generating line.

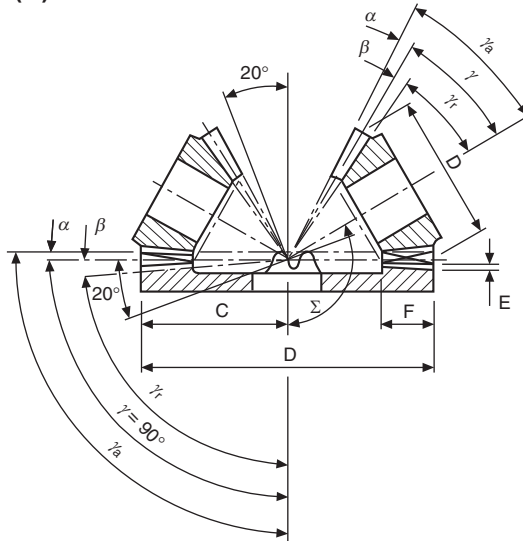
*The root-cone angle* is the angle between the gear axis and the root generating line.

*The face angle* is the angle between the tips of the teeth and the axis of the gear.

*The addendum angle* is the angle between the top of the teeth and the pitch-cone generator.



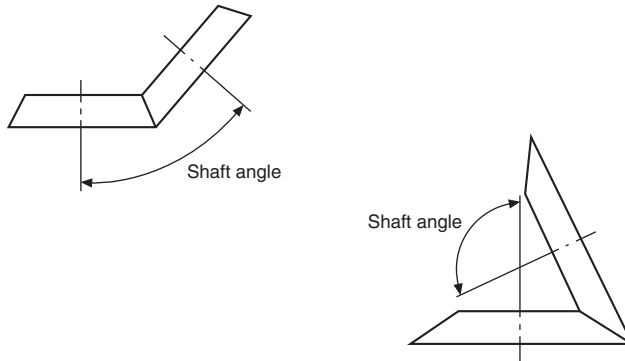
(A)



(B)

- A = addendum
- B = dedendum
- C = cone distance
- D = pitch diameter
- $D_a$  = outside diameter
- $D_r$  = root diameter
- E = bottom clearance
- F = face width
- $\alpha$  (alpha) = addendum angle
- $\beta$  (beta) = dedendum angle
- $\gamma$  (gamma) = pitch angle
- $\gamma_a$  = back cone angle
- $\gamma_r$  = root angle
- $\Sigma$  (sigma) = shaft angle

Fig. 31.24 Bevel-gear terms. (A) Bevel gears. (B) Crown wheel and pinions.

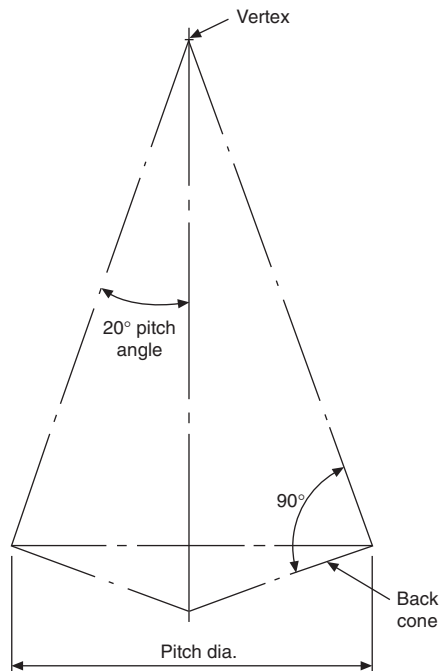


**Fig. 31.25** Bevel-gear cones.

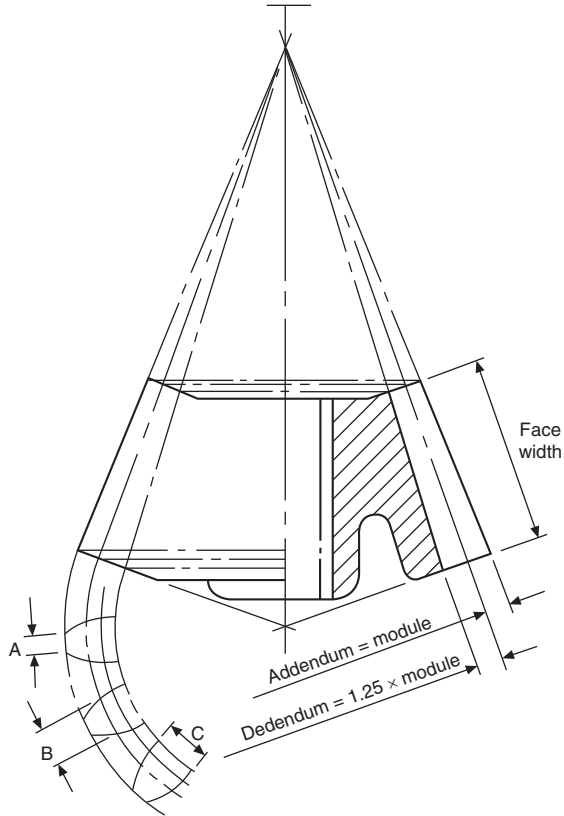
The *dedendum angle* is the angle between the bottom of the teeth and the pitch-cone generator.

The *outside diameter* is the diameter measured over the tips of the teeth.

The following figures (Figs. 31.26 and 31.27) show the various stages in drawing bevel gears. The approximate construction for the profile of the teeth has been described in the section relating to spur gears.



**Fig. 31.26** Stage 1.



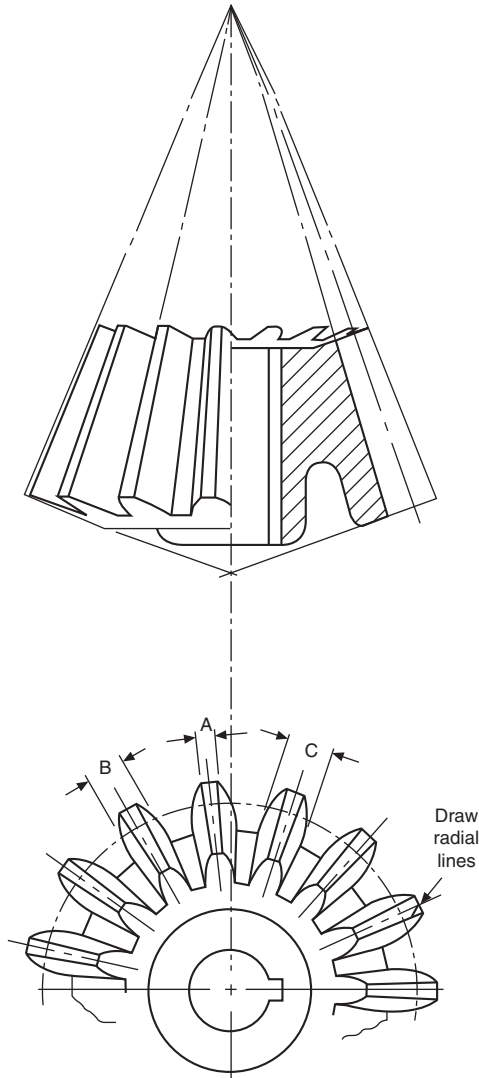
**Fig. 31.27** Stage 2.

*Gear data:* 15 teeth,  $20^\circ$  pitch-cone angle, 100 mm pitch-circle diameter,  $20^\circ$  pressure angle.

*Stage 1* Set out the cone as shown in [Fig. 31.26](#).

*Stage 2* Set out the addendum and dedendum. Project part of the auxiliary view to draw the teeth ([Fig. 31.27](#)).

*Stage 3* Project widths A, B, and C on the outside, pitch, and root diameters, in plan view. Complete the front elevation ([Fig. 31.28](#)).

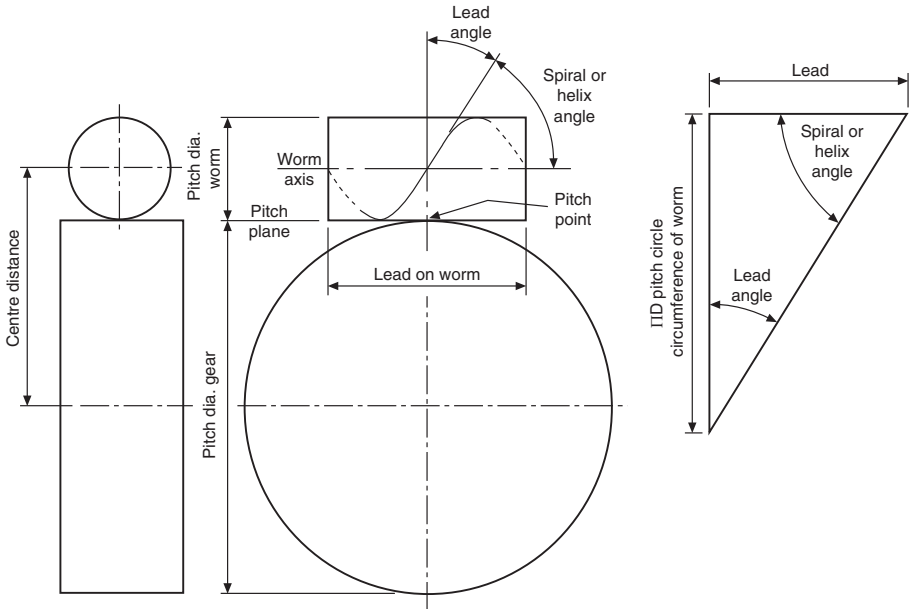


**Fig. 31.28** Stage 3.

## Worm gearing

Worm gearing is used to transmit power between two non-intersecting shafts whose axes lie at right angles to each other. The drive of a worm gear is basically a screw, or worm, which may have a single- or multi-start thread, and this engages with the wheel. A single-start worm in one revolution will rotate the worm wheel one tooth and space, i.e. one pitch. The velocity ratio is high; for example, a 40-tooth wheel with a single-start worm will have a velocity ratio of 40, and in mesh with a two-start thread the same wheel would give a velocity ratio of 20.

A worm-wheel with a single-start thread is shown in [Fig. 31.29](#). The lead angle of a single-start worm is low, and the worm is relatively inefficient, but there is little



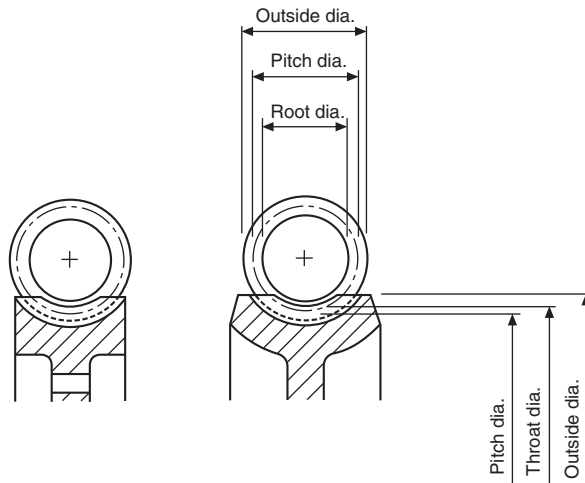
**Fig. 31.29** Single start worm-wheel.

tendency for the wheel to drive the worm. To transmit power, multi-start thread forms are used. High mechanical advantages are obtained by the use of worm-gear drives.

Worm-gear drives have many applications, for example indexing mechanisms on machine tools, torque converters, and slow-motion drives.

Fig. 31.30 shows typical cross-sections through part of a worm and wheel. Note the contour of the wheel, which is designed to give greater contact with the worm.

Recommendations for the representation of many types of gear assembly in sectional and simplified form are given in BS 8888.



**Fig. 31.30** Worm-gearing terms applied to a worm and part of a worm-wheel.

Mechanical springs may be defined as elastic bodies the primary function of which is to deform under a load and return to their original shape when the load is removed. In practice, the vast majority of springs are made of metal, and of these the greatest proportion are of plain-carbon steel.

## Plain-carbon steels

These steels have a carbon-content ranging from about 0.5% to 1.1%. In general it may be taken that, the higher the carbon-content, the better the spring properties that may be obtained.

In the manufacture of flat springs and the heavier coil springs, it is usual to form the spring from annealed material and subsequently to heat treat it. However, it is sometimes possible to manufacture flat springs from material which is already in the hardened and tempered condition, and this latter technique may give a lower production cost than the former.

For light coil springs, the material loosely known as *piano wire* is used; this is a spring wire which obtains its physical properties from cold-working, and not from heat treatment. Springs made from this wire require only a low-temperature stress-relieving treatment after manufacture. Occasionally wire known as *oil-tempered* is used — this is a wire which is hardened and tempered in the coil form, and again requires only a low-temperature stress relief after forming.

Plain-carbon steel springs are satisfactory in operation up to a temperature of about 180 °C. Above this temperature they are very liable to take a permanent set, and alternative materials should be used.

## Alloy steels

Alloy steels are essentially plain-carbon steels to which small percentages of alloying elements such as chromium and vanadium have been added. The effect of these additional elements is to modify considerably the steels' properties and to make them more suitable for specific applications than are the plain-carbon steels. The two widely used alloy steels are:

- (a) chromium—vanadium steel — this steel has less tendency to set than the plain-carbon steels;
- (b) silicon—manganese steel — a cheaper and rather more easily available material than chrome—vanadium steel, though the physical properties of the two steels are almost equivalent.

## Stainless steels

Where high resistance to corrosion is required, one of the stainless steels should be specified. These fall into two categories:

- (a) *Martensitic*. These steels are mainly used for flat springs with sharp bends. They are formed in the soft condition and then heat treated.
- (b) *Austenitic*. These steels are cold-worked for the manufacture of coil springs and flat springs, with no severe forming operations.

Both materials are used in service up to about 235 °C.

## High-nickel alloys

Alloys of this type find their greatest applications in high-temperature operation. The two most widely used alloys are:

- (a) Inconel — a nickel–chrome–iron alloy for use up to about 320 °C.
- (b) Nimonic 90 — a nickel–chromium–cobalt alloy for service up to about 400 °C, or at reduced stresses to about 590 °C.

Both of these materials are highly resistant to corrosion.

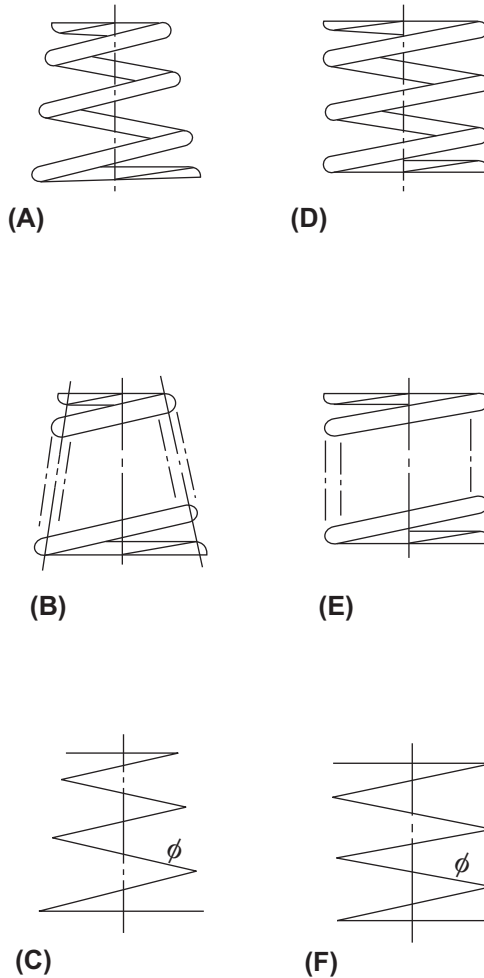
## Copper-base alloys

With their high copper-content, these materials have good electrical conductivity and resistance to corrosion. These properties make them very suitable for such purposes as switch-blades in electrical equipment.

- (a) *Brass* — an alloy containing zinc, roughly 30%, and the remainder copper. A cold-worked material obtainable in both wire and strip form, and which is suitable only for lightly stressed springs.
- (b) *Phosphor bronze* — the most widely used copper-base spring material, with applications the same as those of brass, though considerably higher stresses may be used.
- (c) *Beryllium copper* — this alloy responds to a precipitation heat treatment, and is suitable for springs which contain sharp bends. Working stresses may be higher than those used for phosphor bronze and brass.

## Compression springs

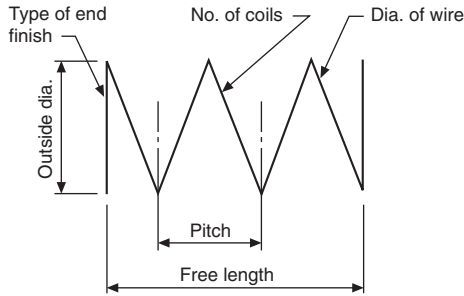
Fig. 32.1 shows two alternative types of compression springs for which drawing conventions are used. Note that the convention in each case is to draw the first and last two turns of the spring and to then link the space in between with a long dashed dotted narrow line. The simplified representation shows the coils of the springs drawn as single lines.



**Fig. 32.1** (A) Conical compression springs with ground ends, (B) section convention, (C) simplified representation, (D) cylindrical compression spring with ground ends, (E) section convention and (F) simplified representation.

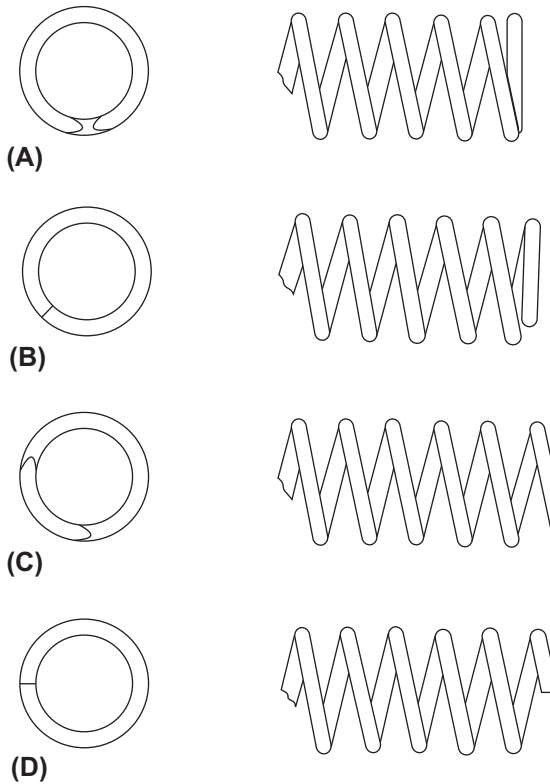
*Note:* If a rectangular section compression spring is required to be drawn then the appropriate shape will appear in view (E), view (D) will be modified with square corners and the  $\phi$  symbol in view (F) will be replaced by  $\square$ .

A schematic drawing of a helical spring is shown in Fig. 32.2. This type of illustration can be used as a working drawing in order to save draughting time, with the appropriate dimensions and details added.



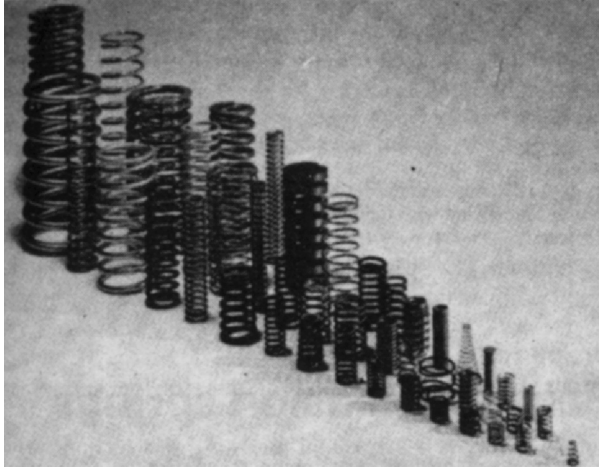
**Fig. 32.2** Schematic drawing of helical spring.

**Fig. 32.3** shows four of the most popular end formations used on compression springs. When possible, grinding should be avoided, as it considerably increases spring costs.



**Fig. 32.3** (A) Closed ends, ground, (B) closed ends, (C) open ends, ground and (D) open ends.

**Fig. 32.4** shows a selection of compression springs, including valve springs for diesel engines and injection pumps.

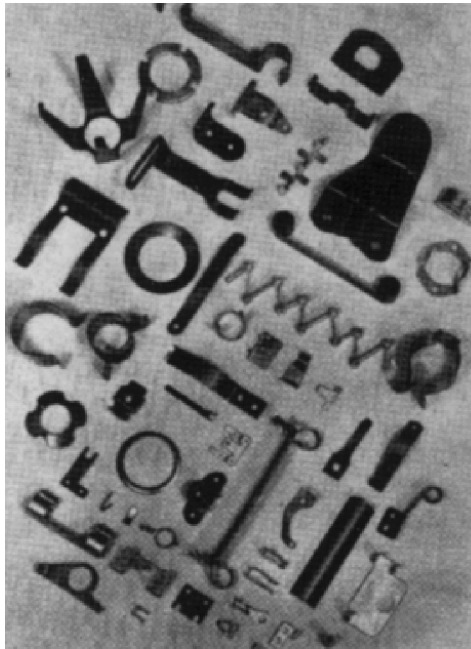


**Fig. 32.4** Compression springs.

## Flat springs

[Fig. 32.5](#) shows a selection of flat springs, circlips, and spring pressings. It will be apparent from the selection that it would be difficult, if not impossible, to devise a drawing standard to cover this type of spring, and at present none exists.

Flat springs are usually made from high-carbon steel in the annealed condition, and are subsequently heat treated; but the simpler types without bends can frequently be



**Fig. 32.5** Flat Springs, circlips and spring pressings.

made more economically from material pre-hardened and tempered to the finished hardness required. Stainless steels are used for springs where considerable forming has to be done. For improved corrosion-resistance, 18/8 stainless steel is recommended; but, since its spring temper is obtained only by cold-rolling, severe bends are impossible. Similar considerations apply to phosphor bronze, titanium, and brass, which are hardened by cold-rolling. Beryllium copper, being thermally hardenable, is a useful material as it can be readily formed in the solution-annealed state.

Fig. 32.6 shows a selection of flat spiral springs, frequently used for brush mechanisms, and also for clocks and motors. The spring consists of a strip of steel spirally wound and capable of storing energy in the form of torque.

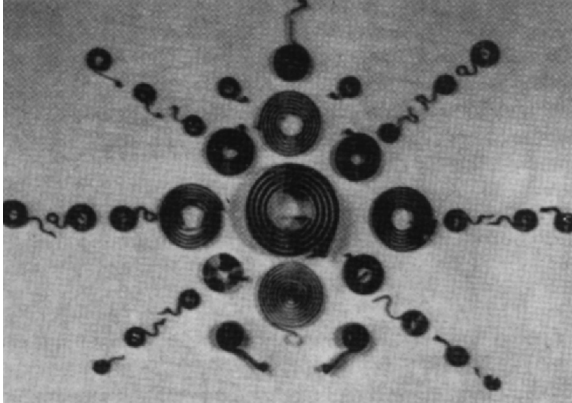


Fig. 32.6 Flat spiral springs.

The standard for spiral springs is illustrated in Fig. 32.7; parts (A) and (B) show how the spring is represented in conventional and simplified forms.

If the spring is close wound and fitted in a housing then the illustrations in (C) and (D) are applicable.

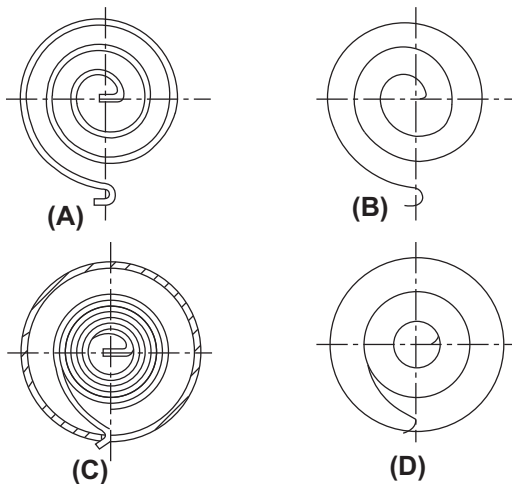
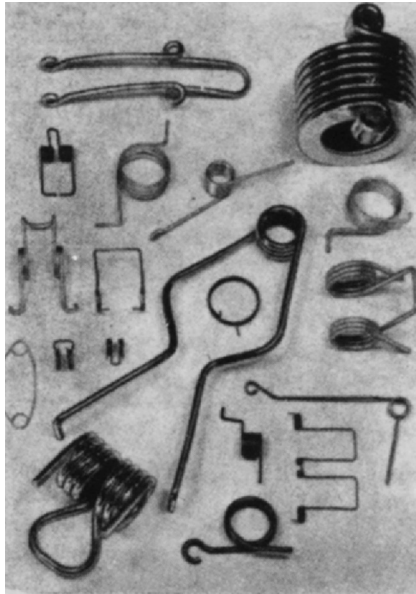


Fig. 32.7 Spiral springs conventional form (A & C) and simplified form (B & D).

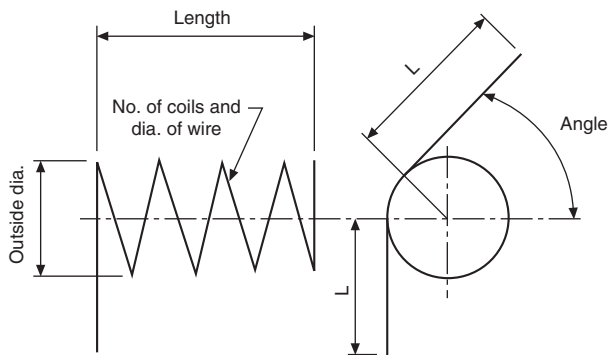
## Torsion springs

Various forms of single and double torsion springs are illustrated in [Fig. 32.8](#).



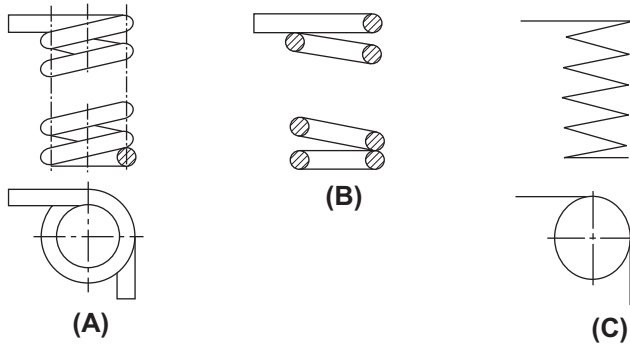
**Fig. 32.8** Single and double torsion springs.

[Fig. 32.9](#) gives a schematic diagram for a torsion spring. This type of drawing, adequately dimensioned, can be used for detailing.



**Fig. 32.9** Schematic drawing of a torsion spring.

The drawing conventions for a cylindrical right-hand helical torsion spring are shown in [Fig. 32.10](#). Part (A) shows the usual drawing convention, part (B) illustrates how to show the spring in a section and part (C) gives the simplified representation.

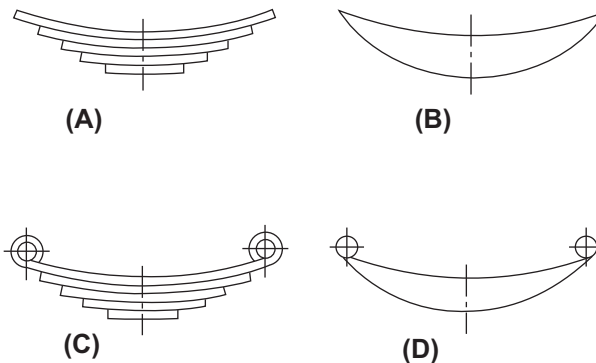


**Fig. 32.10** Drawing conventions of a torsion spring.

Although torsion springs are available in many different forms, this is the only type to be represented in engineering-drawing Standards. Torsion springs may be wound from square-, rectangular-, or round-section bar. They are used to exert a pressure in a circular arc, for example in a spring hinge and in door locks. The ends of the wire in the spring may be straight, curved, or kinked.

## Leaf springs

The two Standards applicable to leaf springs are shown in Fig. 32.11. These springs are essentially strips of flat metal formed in an elliptical arc and suitably tempered. They absorb and release energy, and are commonly found applied to suspension systems.



**Fig. 32.11** (A and B) Conventional and simplified representations for a semi-elliptic leaf spring, (C and D) conventional and simplified representations for a semi-elliptic leaf spring with fixing eyes.

## Helical extension springs

A helical extension spring is a spring which offers resistance to extension. Almost invariably they are made from circular-section wire, and a typical selection is illustrated in Fig. 32.12.

The conventional representations of tension springs are shown in Fig. 32.13 and a schematic drawing for detailing is shown in Fig. 32.14.

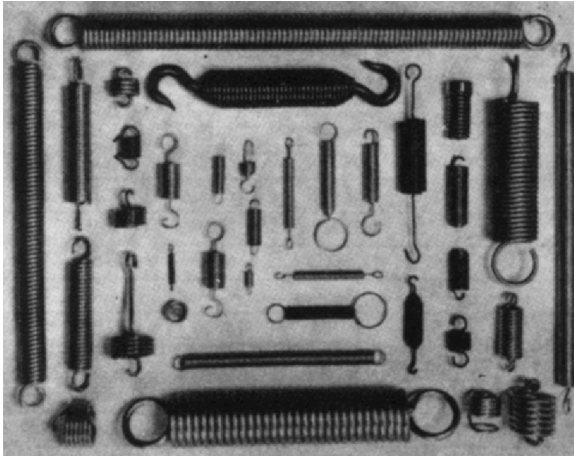


Fig. 32.12 Helical extension springs.

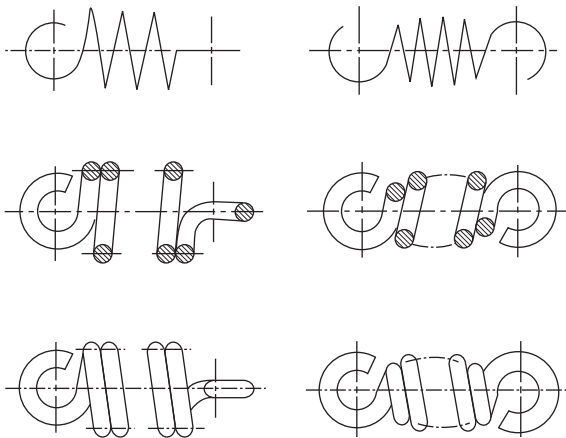


Fig. 32.13 Simplified, section and conventional representation of a tension spring.

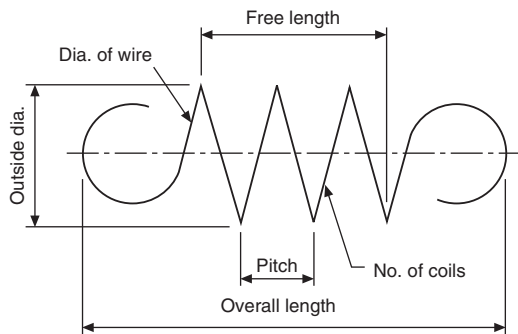
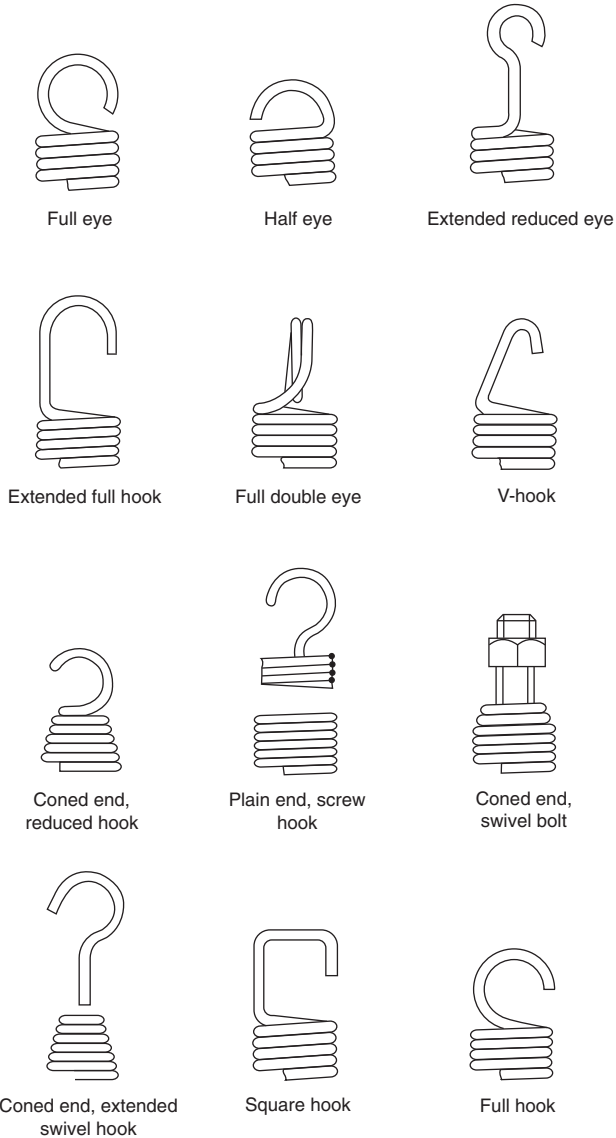


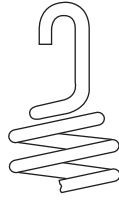
Fig. 32.14 Schematic drawing of tension spring.

Coils of extension springs differ from those of compression springs in so far as they are wound so close together that a force is required to pull them apart. A variety of end loops are available for tension springs, and some of the types are illustrated in Fig. 32.15.



**Fig. 32.15** Types of end loops.

A common way of reducing the stress in the end loop is to reduce the moment acting on it by making the end loop smaller than the body of the spring, as shown in Fig. 32.16.



**Fig. 32.16** Smaller loop end.

## Disc springs

For bolted connections a very simple form of compression spring utilizes a hollow washer manufactured from spring steel, although other materials can be specified.

[Table 32.1](#) shows a selection of Belleville washers manufactured to DIN 6796 from spring steel to DIN 17222.

If the disc has its top and bottom surfaces ground to approximately 95% of the appropriate thickness given in [Table 32.1](#) then bearing surfaces will be formed. These surfaces improve guidance where several discs are used together. [Fig. 32.17](#) shows the disc spring with flats.

A disc spring stack with six springs in single series is given in [Fig. 32.18](#). In this arrangement six times the number of individual spring deflections are available. The force available in the assembly is equivalent to that of a single disc spring. In single series, concave and convex surfaces are opposed alternatively.

[Fig. 32.19](#) shows three disc springs assembled in parallel with the convex surface nesting into the concave surface. Here the deflection available is equivalent to that of a single spring and the force is equal to three times that of an individual disc.

The methods of assembly illustrated in [Figs. 32.18 and 32.19](#) can be combined to give many alternative selections of force and deflection characteristics. In the stack given in [Fig. 32.20](#) there are four disc spring components assembled in series and they each contain two disc springs assembled in parallel. This combination will give a force equal to twice that of an individual disc and a deflection of four times that of an individual disc.

Belleville washers are manufactured by Bauer Springs Ltd., of Eagle Road, North Moon Moat Industrial Estate, Redditch, Worcestershire, B98 9HF where full specifications are freely available.

Drawing conventions for these springs are given in [Fig. 32.21](#), and show (A) the normal outside view, (B) the view in section and (C) the simplified representation. These conventions can be adapted to suit the disc combination selected by the designer.

## Spring specifications

A frequent cause of confusion between the spring supplier and the spring user is lack of precision in specifying the spring. This often results in high costs due to the

**Table 32.1** A selection of Belleville washers manufactured to DIN 6796 from spring steel to DIN 17222.

Notation	$d$ (mm) H 14	$d$ (mm) h 14	$h$ (mm)			Force <sup>a</sup>	Test force <sup>b</sup>	Weight (kg/1000 $\approx$ )	Core diameter
			max. <sup>c</sup>	min. <sup>d</sup>	$s^e$ (mm)				
2	2.2	5	0.6	0.5	0.4	628	700	0.05	2
2.5	2.7	6	0.72	0.61	0.5	946	1,100	0.09	2.5
3	3.2	7	0.85	0.72	0.6	1,320	1,500	0.14	3
3.5	3.7	8	1.06	0.92	0.8	2,410	2,700	0.25	3.5
4	4.3	9	1.3	1.12	1	3,770	4,000	0.38	4
5	5.3	11	1.55	1.35	1.2	5,480	6,550	0.69	5
6	6.4	14	2	1.7	1.5	8,590	9,250	1.43	6
7	7.4	17	2.3	2	1.75	11,300	13,600	2.53	7
8	8.4	18	2.6	2.24	2	14,900	17,000	3.13	8
10	10.5	23	3.2	2.8	2.5	22,100	27,100	6.45	10
12	13	29	3.95	3.43	3	34,100	39,500	12.4	12
14	15	35	4.65	4.04	3.5	46,000	54,000	21.6	14
16	17	39	5.25	4.58	4	59,700	75,000	30.4	16
18	19	42	5.8	5.08	4.5	74,400	90,500	38.9	18
20	21	45	6.4	5.6	5	93,200	117,000	48.8	20
22	23	49	7.05	6.15	5.5	113,700	145,000	63.5	22
24	25	56	7.75	6.77	6	131,000	169,000	92.9	24
27	28	60	8.35	7.3	6.5	154,000	221,000	113	27
30	31	70	9.2	8	7	172,000	269,000	170	30

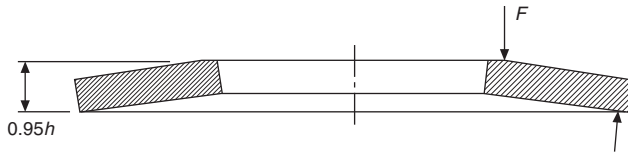
<sup>a</sup> This force applies to the pressed flat condition and corresponds to twice the calculated value at a deflection  $h - s$ .

<sup>b</sup> The test force applies for the loading tests to DIN 6796.

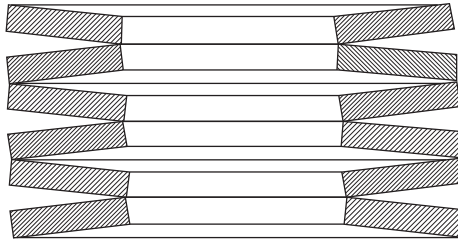
<sup>c</sup> Max. size in delivered condition.

<sup>d</sup> Min. size after loading tests to DIN 6796.

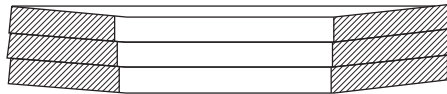
<sup>e</sup> Permissible range of tolerance of  $s$  to DIN 1544 and DIN 1543 respectively for  $s > 6$  mm.



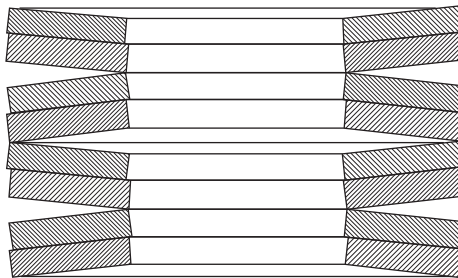
**Fig. 32.17** Single disc spring.



**Fig. 32.18** Stack of disc springs in series.



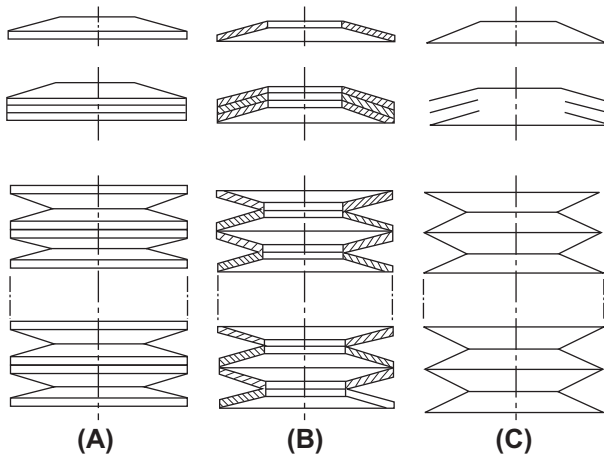
**Fig. 32.19** Stack of disc springs in parallel.



**Fig. 32.20** Stack of 2 parallel disc springs in series.

manufacturer taking considerable trouble to meet dimensions which are not necessary for the correct functioning of the spring.

It is recommended that, while all relevant data regarding the design should be entered on the spring detail drawing, some indication should be given as to which of the particular design points must be adhered to for the satisfactory operation of the component; this is necessary to allow for variations in wire diameter and elastic modulus of the material. For example, a compression spring of a given diameter



**Fig. 32.21** Drawing conventions for disc springs.

may, if the number of coils is specified, have a spring rate which varies between  $\pm 15\%$  of the calculated value. In view of this, it is desirable to leave at least one variable for adjustment by the manufacturer, and the common convenient variable for general use is the number of coils.

A method of spring specification which has worked well in practice is to insert a table of design data, such as that shown below (see p. 274), on the drawing. All design data are entered, and the items needed for the correct functioning of the spring are marked with an asterisk. With this method the manufacturer is permitted to vary any unmarked items, as only the asterisked data are checked by the spring user's inspector. The following are specifications typical for compression, tension and torsion springs.

<b>Compression spring</b>	
Total turns	7
Active turns	5
Wire diameter	1 mm
*Free length	$12.7 \pm 0.4$ mm
*Solid length	7 mm max.
*Outside coil diameter	7.6 mm max.
*Inside coil diameter	5 mm
Rate	7850 N/m
*Load at 9 mm	$31 \pm 4.5$ N
Solid stress	$881 \text{ N/mm}^2$

*Ends	Closed and ground
Wound	Right-hand or left-hand
*Material	S202
*Protective treatment	Cadmium-plate
<b>Tension spring</b>	
Mean diameter	11.5 mm
*O.D. max.	13.5 mm
*Free length	54 ± 0.5 mm
Total coils on barrel	16½
Wire diameter	1.62 mm
*Loops	Full eye, in line with each other and central with barrel of spring
Initial tension	None
Rate	2697 N/m
*Load	53 ± 4.5 N
*At loaded length	73 mm
Stress at 53 N	438 N/mm <sup>2</sup>
Wound	Right-hand or left-hand
*Material	BS 1408 B
*Protective treatment	Lanolin
<b>Torsion spring</b>	
Total turns on barrel	4
Wire diameter	2.6 mm
*Wound	Left-hand close coils
Mean diameter	12.7 mm
*To work on	9.5 mm diameter bar
*Length of legs	28 mm
*Load applied at	25.4 mm from center of spring
*Load	41 ± 2 N
*Deflection	20°
Stress at 41 N	595 N/mm <sup>2</sup>
*Both legs straight and tangential to barrel	
*Material	BS 5216
*Protective treatment	Grease

## Wire forms

Many components are assembled by the use of wire forms which are manufactured from piano-type wire. Fig. 32.22 shows a selection, though the number of variations is limitless.

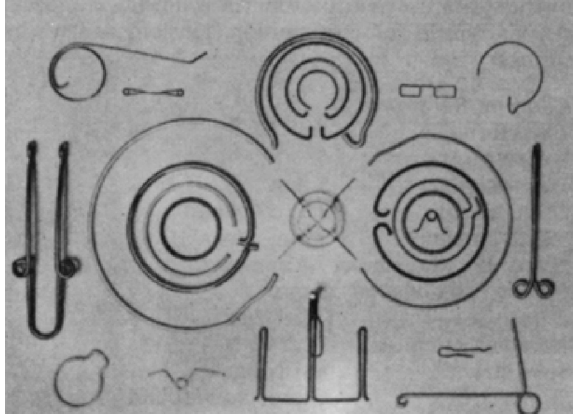


Fig. 32.22 Wire form components.

## Corrosion prevention

Springs operating under severe corrosive conditions are frequently made from phosphor bronze and stainless steel, and occasionally from nickel alloys and titanium alloys. For less severe conditions, cadmium- or zinc-plating is recommended; alternatively, there are other electroplatings available, such as copper, nickel, and tin. Phosphate coatings are frequently specified. Organic coatings, originally confined to stove enamels, now include many plastics materials such as nylon and polythene, as well as many types of epoxy resins.

## Fatigue conditions

Many springs, such as valve springs, oscillate rapidly through a considerable range of stress and are consequently operating under conditions requiring a long fatigue life. The suitability of a spring under such conditions must be considered at the detail design stage, and a satisfactory design and material must be specified. Special treatments such as shot-peening or liquid-honing may be desirable. In the process of shot-peening, the spring is subjected to bombardment by small particles of steel shot; this has the effect of workhardening the surface. Liquid honing consists of placing the spring in a jet of fine abrasive suspended in water. This has a similar effect to shot-peening, and the additional advantage that the abrasive stream removes or reduces stress raisers on the spring surface.

# Welding and welding symbols

33

The science of welding and allied processes plays a major part in engineering design and manufacturing activities; the general versatility and in some cases the sophistication of welding processes enables the designer to create a vast range of fabrications to meet their design intent.

In general, welding may be described as the process of uniting two pieces of material (usually metal but other materials can be welded) by raising the temperature of the material in the vicinity of the joint so it becomes plastic or molten, creating the join. The welding process can be carried out with or without pressure and with or without added material.

There are two main classes of welding, each with a subset of differing processes; these classes are *fusion welding* and *welding with pressure*. Common examples of fusion welding are arc, gas and electron beam welding; common examples of pressure welding are spot, ultrasonic and diffusion welding.

*Fusion welding* is a process whereby the material in the vicinity of the joint becomes molten, fusing the parts together. The heat required to melt the material is usually provided by a gas flame or electric arc. A filler material can be used to build up the material around the welded joint if need be; a good example of the use of a filler material is a *fillet weld*.

To prevent oxidation of the weld during the fusion process a flux can be utilized to form a barrier: 'stick' (consumable electrode) arc welding or submerged arc welding are good examples. Another method commonly used is to provide an inert atmosphere around the weld. This is achieved by shrouding the weld at the point of fusion with an inert gas such as carbon dioxide or argon. Metal inert gas (MIG) and tungsten inert gas (TIG) are good examples of this method.

*Welding with pressure* is a process whereby the areas on the parts to be joined are held together under mechanical pressure and the surfaces at the area to be welded are heated to and maintained in a plastic state. Heating for this process is usually provided by resistance to an electric current (often called *resistance welding*). 'Spot' welding is probably the most widely recognized method of this type of welding process.

Designers should be aware that although the use of welded fabrications facilitates a wide range of design options, there are some limitations which need to be considered. The following considerations are provided as a guide and are not exhaustive.

Welding introduces heat into the part and this can lead to distortion caused by stresses within the material; distortion can also occur when machining a welded part. Heat can also alter the mechanical properties of the material, especially in the area of the weld. Post welding heat treatment of the part, such as annealing or normalizing or the use of weld chills, i.e. thermally conductive material such as copper placed on the surface near the weld zone, can overcome most heat related problems. It should

be noted that in large welded fabrications heat treatment may be required during the fabrication process. The use of electron beam or laser welding techniques introduces very little heat into the part and as a result the parts welded by these methods generally don't require any heat treatment.

The choice of filler material can be critical to the strength and performance of a weld. Generally, the filler material should be of the same type as or compatible with the parent material; many examples of weld failure can be attributed to using a dissimilar material as a filler.

Accessibility to perform the welding process should be considered; often there is not sufficient space to complete (or inspect) a weld leading to redesign and/or rework.

Inspection of welds is usually by non-destructive testing methods such as dye penetrate, ultrasonic or X-Ray, so, as above, accessibility to perform the inspection is crucial, greater accessibility to inspect the weld may be required so it is advised to consult with the NDT experts when space is an issue.

Designers considering using complex welds or experiencing welding problems are advised to contact the Welding Institute ([www.twiprofessional.com](http://www.twiprofessional.com)) for professional advice and guidance.

## **The indication and application of welding symbols on drawings**

### ***General***

The authors feel that it essential that the reader should be made aware that currently two Standards exist for the indication of welding symbols, both of which are widely used worldwide: the International Standard ISO 2553 and the American Standard AWS A2.4.

For one Standard only to be chosen, for mutual acceptance, it would mean half the global users of either Standard would have to change over to the dictates of the other. Many meetings between these two Standards committees have been held to resolve this issue — even the possibility of having a totally new system has been discussed; however, none of the options considered has proved to be acceptable to either committee.

In an effort to find a resolution to break this apparent deadlock a questionnaire was distributed to all member bodies requesting their opinions on the best way forward. The result was to include both systems in one cohabitation Standard, as long as they did not conflict with each other.

This has now been achieved with the revision of ISO 2553: 2013, which clearly and unambiguously identifies and illustrates the two systems. The ISO version is identified as System A and the American version is identified as System B, thus achieving one acceptable global Standard. These systems must never be shown mixed and drawings must clearly indicate which system and units are used.

The content of this chapter is in accordance with the content of BS EN ISO 2553: 2013. System A is illustrated unless stated otherwise.

The following notes are meant as a guide to the method of applying the more commonly used welding symbols relating to the simpler types of welded joints on engineering drawings. Where complex joints involve multiple welds it is often easier to detail such constructions on separate drawing sheets. Refer to BS EN ISO 2553: 2013 for the full specification of symbolic representations for welds.

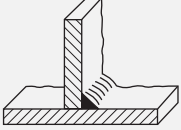



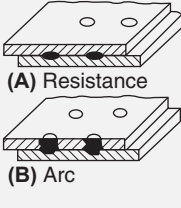

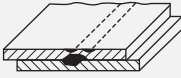

Each type of weld is characterized by a symbol given in Table 33.1. Note that the symbol is representative of the shape of the weld, or the edge preparation, but does not indicate any particular welding process and does not specify either the number of runs to be deposited or whether or not a root gap or backing material is to be used. These details would be provided on a welding procedure schedule for the particular job.

**Table 33.1** Elementary weld symbols.

Form of weld	Illustration	ISO symbol
Flange butt/Corner weld		
Flare V		
Square butt weld		
Single-V butt weld		
Single-bevel butt weld		
Single-V butt weld with broad root face		
Single-bevel butt weld with broad root face		
Single-U butt weld		
Single-J butt weld		
Backing or sealing run		

*Continued*



**Table 33.1** Elementary weld symbols.—cont'd

Form of weld	Illustration	ISO symbol
Fillet weld		
Plug weld (circular or elongated hole, completely filled)		
Spot weld (resistance or arc welding) or projection weld	 <p>(A) Resistance</p> <p>(B) Arc</p>	
Seam weld		









All butt welds are full penetration unless otherwise indicated by dimensions on the weld symbol.

It may be necessary to specify the shape of the weld surface on the drawing as flat, convex or concave and a supplementary symbol, shown in [Table 33.2](#), is then added to the elementary symbol. An example of each type of weld surface application is given in [Table 33.3](#).

**Table 33.2** Supplementary symbols.

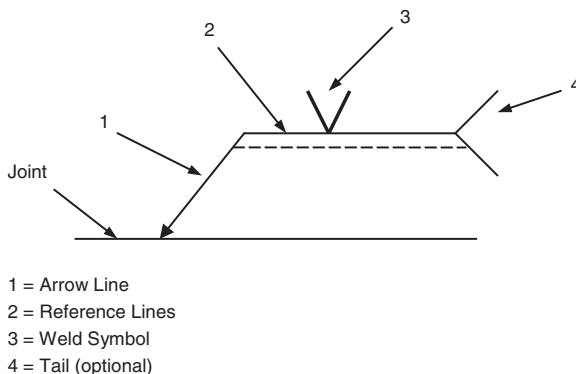
Shape of weld surface	ISO symbol
Flat (usually finished flush)	
Convex	
Concave	

**Table 33.3** Some examples of the application of supplementary symbols.

Form of weld	Illustration	ISO symbol
Flat (flush) single-V butt weld		
Convex double-V butt weld		
Concave fillet weld		
Flat (flush) single-V butt weld with flat (flush) backing run		

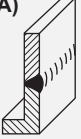
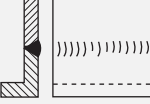
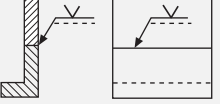
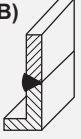
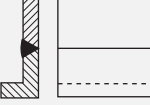
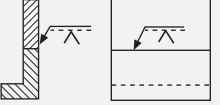


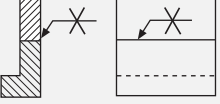

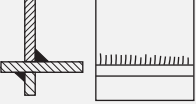
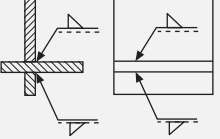
A joint may also be made with one type of weld on a particular surface and another type of weld on the back and in this case elementary symbols representing each type of weld used are added together. The last example in [Table 33.3](#) shows a single-V butt weld with a backing run where both surfaces are required to have a flat finish.

A welding symbol is applied to a drawing by using reference lines and an arrow line as shown in [Fig. 33.1](#). The reference lines (one continuous and one dashed) should be drawn parallel to the bottom edge of the drawing frame. The dashed reference line can be positioned above or below the continuous reference line but it is preferable to position it below. The arrow line forms an angle with the continuous reference line. The side of the joint nearer to the arrowhead is known as the *arrow side* and the opposite side of the joint is known as the *other side*. The continuous reference line relates to the *arrow side* and the dashed reference line relates to the *other side*.

**Fig. 33.1** Elements of a welding symbol.

The welding symbol should be positioned on the reference lines as indicated in Table 33.4 and Fig. 33.1.

**Table 33.4** Significance of the arrow and the position of the weld symbol.

Illustration	Graphic representation	Symbolic representation
(A) 		
(B) 		
(C) 		
(D) 		

Sketch (A) shows the symbol for a single-V butt weld positioned on the continuous reference line; this is because the weld is on the *arrow side* of the joint.

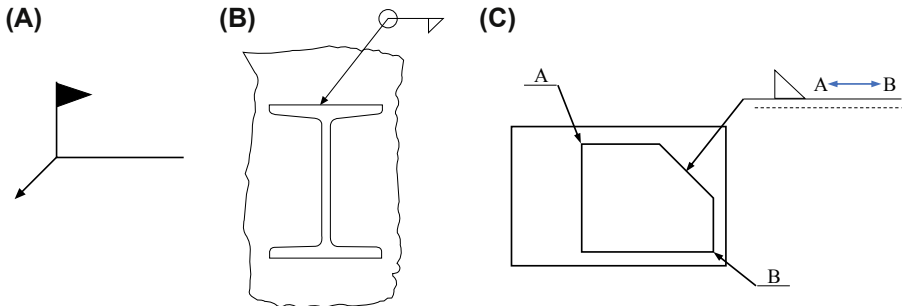
Sketch (B) shows the same symbol positioned on the dashed reference line; this is because the weld is on the *other side* of the joint (opposite to the arrow line).

Sketch (C) shows the symbol applied to a double-V butt weld; in this case the dashed line is omitted and both symbols are positioned on the continuous reference line. There is no requirement to show the dashed reference line when specifying symmetrical welds or spot and seam welds made at the interface between two components.

Sketch (D) shows fillet welds on a cruciform joint where the top weld is on the *arrow side* and the bottom weld is on the *other side* of the joint. In these cases, for the top weld the weld symbol is positioned on the continuous reference line and for the bottom weld the symbol is positioned on the dashed reference line.

The positioning of the symbol is the same for drawings in first or third angle projection.

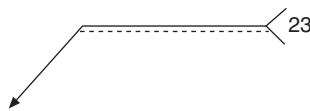
Additional symbols can be added to the reference line as shown in Fig. 33.2. Welding can be done in the factory or in the field or on site when plant is erected. A field/site weld is indicated by a flag. A continuous weld all round a joint is shown by a circle at the intersection of the arrow and the reference line. Note that if a continuous weld is to be undertaken in the field or on site then both symbols should be added to the drawing. Continuous welds of the same type between two points can be designated by the use of the between symbol as shown in Fig. 33.2C. The endpoints of the weld should be clearly identified, and the weld symbol should clearly indicate the weld.



**Fig. 33.2** Indication of (A) field/site welds (B) continuous welds and (C) welds between two points.

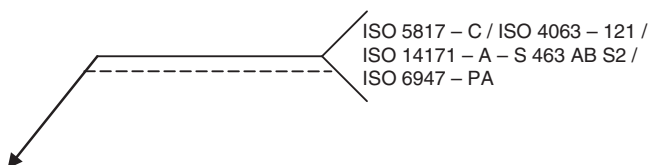
The tail is an optional element which can be added to the end of the continuous reference line (see Fig. 33.3) where additional complementary information can be included as part of the welding symbol. (The projection welding process is indicated in the example in Fig. 33.3). The following information can be specified:

- (a) the level of quality, for example in accordance with ISO 5817, ISO 10042, ISO 13919, etc.;
- (b) the welding process, reference number or abbreviation in accordance with ISO 4063;
- (c) the filler material, for example in accordance with ISO 14171, ISO 14341, etc.;
- (d) the welding position, for example in accordance with ISO 6947;
- (e) any supplementary information to be considered when making the joint.



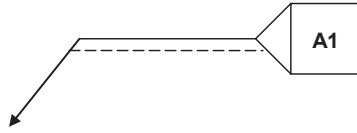
**Fig. 33.3** Weld symbol with complimentary information tail indication projection welding.

The information shall be listed and separated by a forward slash (/) (see Fig. 33.4).



**Fig. 33.4** Separation of information.

A closed tail shall only be used to indicate reference to a specific instruction, e.g. reference to a welding procedure or specification (see Fig. 33.5).



**Fig. 33.5** Weld symbol with reference to a specific instruction.

Repetition of additional information on symbols on a drawing is not advised. A single general note on the drawing should be used instead.

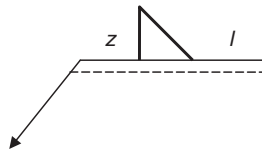
Useful Standards for the designer are as follows: BS 499-1, which gives an extensive glossary for welding, brazing and thermal cutting and includes seven sections relating to welding with pressure, fusion welding, brazing, testing, weld imperfections, and thermal cutting and although lengthy, is a highly recommended read to understand the processes; BS 499-1 Supplement, which gives definitions for electrical and thermal characteristics of welding equipment.

European arc welding symbols in chart form are illustrated in BS 499-2C.

Symbolic representation on drawings for welded, brazed and soldered joints are illustrated in BS EN ISO 22553. Welded and allied processes, nomenclature of processes and reference numbers are given in BS EN ISO 4063:2010.

## Dimensioning of welds

The dimensions of a weld may be added to a drawing in the following manner (Fig. 33.6).



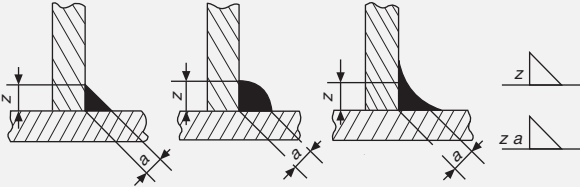
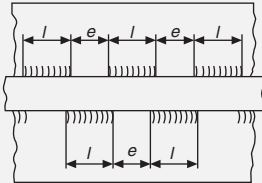
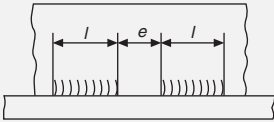
**Fig. 33.6** Position of weld dimensions on the symbol.

Dimensions relating to the cross-section of the weld are symbolized by  $z$  and are given on the left-hand side of the symbol. The cross-sectional dimension to be indicated for a fillet weld is the leg length. If the design throat thickness is to be indicated then the leg-length dimension is prefixed with the letter  $z$  and the design throat thickness with the letter  $a$ .

Longitudinal dimensions are symbolized by  $l$  and are given on the right-hand side of the symbol. If the weld is not continuous then distances between adjacent weld elements are indicated in parentheses. Unless dimensional indication is added to the contrary, a fillet weld is assumed to be continuous along the entire length of the weld. Leg-length dimensions of fillet welds of 3, 4, 5, 6, 8, 10, 12, 16, 18, 20, 22, and 25 mm are the preferred sizes.

Applications of dimensions to different types of fillet welds are given in [Table 33.5](#) in order to indicate the scope of the British Standard, which should be consulted to fully appreciate this topic. In [Table 33.5](#), (1) shows dimensions applied to continuous fillet welds, (2) shows dimensions applied to intermittent fillet welds, and (3) shows dimensions applied to staggered intermittent fillet welds.

**Table 33.5** The dimensioning of welds.

Definition	Inscription
 <p><math>z</math> is the leg length  <math>a</math> is the design throat thickness</p> <p>(1) Continuous fillet welds</p>	
 <p><math>l</math> is the length of weld (without end craters)  <math>e</math> is the distance between adjacent weld elements  <math>n</math> is the number of weld elements  <math>z</math> and <math>a</math> as defined above</p> <p>(2) Staggered intermittent fillet weld</p>	$\frac{z}{z} \triangleleft \frac{n \times l}{n \times l} \begin{matrix} (e) \\ (e) \end{matrix}$ $\frac{z a}{z a} \triangleleft \frac{n \times l}{n \times l} \begin{matrix} (e) \\ (e) \end{matrix}$
 <p><math>a</math>, <math>z</math>, <math>l</math>, <math>e</math> and <math>n</math> as defined above</p> <p>(3) Intermittent fillet welds</p>	$\frac{z}{z} \triangleleft n \times l (e)$ $\frac{z a}{z a} \triangleleft n \times l (e)$

The following list gives details of Standards and publications which will provide a major source of reference material for use in the preparation of various types of engineering diagram.

## General engineering graphical symbols

Construction Drawing Series lists the following:

- BS 1192** Collaborative production of architectural engineering and construction informative code of practice
- BS EN ISO 6284** Indication of limit deviations
- BS EN ISO 8560** Representations of modular sizes, lines and grids
- BS EN ISO 9431** Spaces for drawing for text and title block on drawing
- BS EN ISO 3766** Simplified representation of concrete reinforcement
- BS EN ISO 7518** Simplified representation of demolition and rebuilding
- BS EN ISO 11,091** Landscape drawing practice

## *General engineering graphical symbol series*

BS 1553: Specification for graphical symbols for general engineering.

**Part 1** *Piping systems and plant*: This section deals with graphical symbols for use in the creation of flow and piping plant and heating and ventilation installations.

**Part 2** *Graphical symbols for power generating plant*: Includes steam and internal combustion engines and turbines, also auxiliary plant.

**Part 3** *Graphical symbols for compressing plant*: Includes applications to air operated switchgear.

## *Fluid power systems and components*

BS 2917-1 specification for graphical symbols.

## *Electrical power*

IEC 60,617-2: Graphical symbols for diagrams. Symbol elements, qualifying symbols, and other symbols having general application.

*Note:* In 2002 the IEC (International Electrotechnical Commission) launched an ‘on-line’ database format for the symbol library (available on subscription from the IEC website). Following this decision, in 2002 CENELEC (European Committee

for Electrotechnical Standardization) decided to cease publication of EN 60,617 in 'paper form', to withdraw the then existing Standards and formally to adopt the IEC database without changes for use in Europe. Consequently the British Standard versions were withdrawn.

The database is the official source of IEC 60,617, and it currently includes some 1750 symbols.

Engineering diagram drawing practice is covered by the following Standards:

BS 61,082-1 Preparations of documents used in electrotechnology. Rules. (This Standard replaces the now withdrawn Standards BS 5070-1 and BS 5070-2).

BS 5070-3 Recommendations for mechanical/fluid flow diagrams. Gives principles and presentation for mechanical, hydraulic, pneumatic, topographic, block, circuit, piping, inter-connection, and supplementary diagrams.

BS 5070-4 Recommendations for logic diagrams. Principles and presentation. Covers signal names, characteristics and logic circuit diagrams.

The diagrams which follow are representative of various branches of engineering and obviously every application will be different. The examples can only indicate the type of diagram one is likely to encounter. The Standards listed will provide a valuable source of information relating to layout content and the appropriate symbols to be used (Table 34.1).

## Engineered systems

All of the engineering specialties referred to at the start of this chapter need diagrams and circuits in order to plan and organize the necessary work. It is very difficult to standardize aspects of work of such a varied nature; however, the following general notes are applicable in most circumstances.

### ***Block diagrams***

Block symbols or outlines are used to indicate the main separate elements in an installation and how they are functionally linked together. The diagram needs to be simple, so that the basics of the operation it represents can be appreciated quickly.

The block symbols refer to single hardware items or self-contained units without necessarily indicating all of the exact connections.

A block diagram can be presented to show a sequence of events to the reader and be used for fault diagnosis.

### ***Circuit diagrams***























The term *circuit* suggests electrical components wired together but this need not be the only case. The circuit could show parts of a central heating system connected by water piping or units in an air conditioning system joined together by fabricated ductwork.

**Table 34.1** Common symbols used on engineering diagrams.

	Direct current		Battery of accumulators or primary cells		Conductor, group of conductors, line, cable, circuit, transmission path (for example, for microwaves)
	Alternating current				Form 1 Three conductors
	Positive polarity		Fuse, general symbol		-01-03 Form 2 Three conductors
	Negative polarity		Fuse with the supply side indicated		Conductors in a cable, three conductors shown
	Propagation, energy flow, signal flow, one way		Connecting link, closed		Earth or ground, general symbol
	Terminal strip, example shown with terminal markings		Connecting link, open		Antenna
	Junction of conductors		Circuit breaker		Ammeter
	Double junction of conductors				Oscilloscope
	Crossing of conductors with no electrical connection				Voltmeter
	Data highway				Galvanometer
	Primary cell or accumulator				Earphone
<i>Note - The longer line represents the positive pole, the short line the negative pole. The short line may be thickened for emphasis</i>					
	Inductor, coil, winding, choke		Polarized capacitor, for example, electrolytic		Loudspeaker
	Inductor with magnetic core		Variable capacitor		Transducer head, general symbol
	Inductor with tapplings, two shown		Make contact normally open; also general symbol for a switch		Clock, general symbol
	Transformer with magnetic core		Break contact		Laser (optical maser, general symbol)
	Machine, general symbol The asterisk is replaced by a letter designation as follows: C synchronous converter G generator GS synchronous generator M motor MG machine capable of use as a generator or motor MS synchronous motor		Change-over contact, break before make		Contactor, normally open
	Socket (female), pole of a socket		Contactor, normally closed		Operating device (relay coil), general symbol
	Plug (male), pole of plug		Coil of an alternating current relay		Mechanical coupling
	Plug and jack, telephone type, two-pole		Wattmeter		Semiconductor diode, general symbol
<i>Note - The longest pole on the plug represents the tip of the plug, and the shortest the sleeve</i>					
			Light emitting diode, general symbol		Tunnel diode

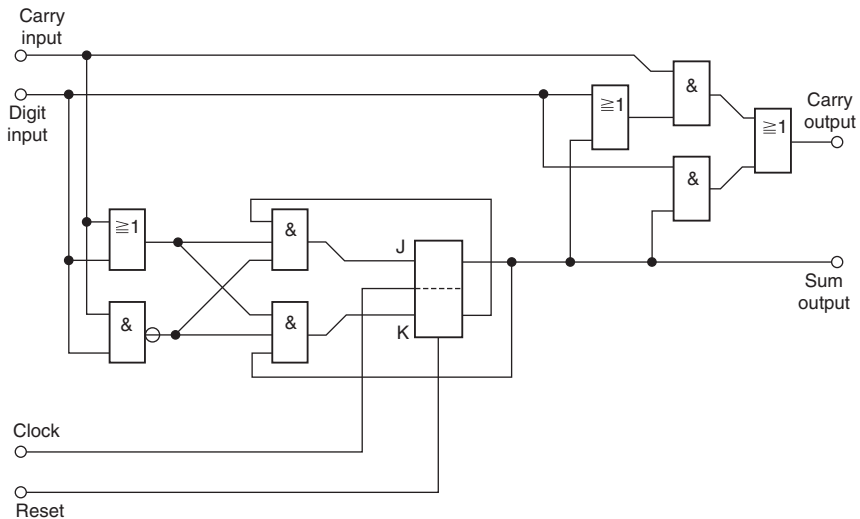
*Continued*

**Table 34.1** Common symbols used on engineering diagrams.—cont'd

	Coaxial plug and socket		Watt-hour meter		Triode thyristor, type unspecified
	Variability, non-inherent		Signal lamp, general symbol		PNP transistor
	Pre-set adjustment		Spotlight		NPN transistor with collector connected to the envelope
	Resistor, general symbol		Luminaire, fluorescent, general symbol		Unijunction transistor with P-type base
	Variable resistor		With three fluorescent tubes		Junction field effect transistor with N-type channel
	Resistor with sliding contact		Bell		Photovoltaic cell
	Heating element		Buzzer		
	Capacitor, general symbol		Microphone		

### Theoretical circuit diagrams

Design staff will prepare theoretical circuit diagrams where all the necessary connections for the correct operation of the system are included. Different sections of industry freely use other terms, such as *schematics*, *sequence diagrams* and *flow charts* (see Fig. 34.1).



**Fig. 34.1** Example of a circuit diagram.

In all these diagrams, the component parts are arranged neatly and if possible horizontally or vertically. If several diagrams form a set, then the style of presentation should be consistent.

One of the conventions with this type of diagram is that components should be arranged so that the sequence of events can be read from left to right, or top to bottom, or perhaps a combination of both.

The diagram does not differentiate between the physical sizes of the separate components. The actual component shape may not be reflected in the standardized symbols and the arrangement on the diagram will not attempt to indicate the true layout of all the items.

Basic engineering practice follows where specifications will be produced for all parts of the system covering, for example, the components in detail, materials, manufacturing processes, relevant Standards, inspection procedures, delivery dates and costs. The customer needs to know exactly what is being supplied, and details of financial arrangements. Contracts will be exchanged when supplier and client are satisfied. Obviously failure of any aspect of an agreement may involve either party in financial loss and litigation could follow. It is of course in nobody's interest that this should occur.

## ***Construction diagrams***

When the system is engineered, the actual position of each component part will dictate the arrangement of wiring, piping and general services, etc. The engineer will need to divide the work according to the scale of the contract and define which diagrams are necessary.

A production circuit diagram for an electrical control panel would show how the panel was built, with all the necessary line and neutral wiring connections in their exact places together with earth links. An exact construction record is essential for service requirements. Wiring must be sized. Standards for current capacity dictate the wire dimensions. Wires are often color coded to facilitate tracing. Wires are run singly, in multicored cables, in looms and conduits, inside and outside, and in almost every conceivable ambient situation.

Clear, accurate and presentable layouts are essential in the production of engineering diagrams. Clarity depends on sufficient thought being given to spacing not only the symbols but associated notes and references.

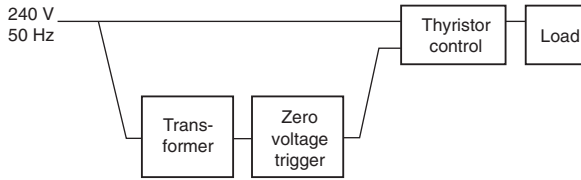
Fig. 34.2 shows a thyristor control system:

Part (a) outlines the basic blocks.

Part (b) provides added detail to the four parts.

Part (c) gives the component connections for the zero voltage trigger with waveforms at various points.

Part (d) is an example of a supplementary diagram where the waveforms are related to a common datum.



*Note.* This diagram forms an introduction to the basic system concept highlighting the major functional areas of the overall system. It is intended for users who require a basic appreciation of the system.

**Fig. 34.2a** Block diagram.

## Heating, ventilation and air conditioning systems

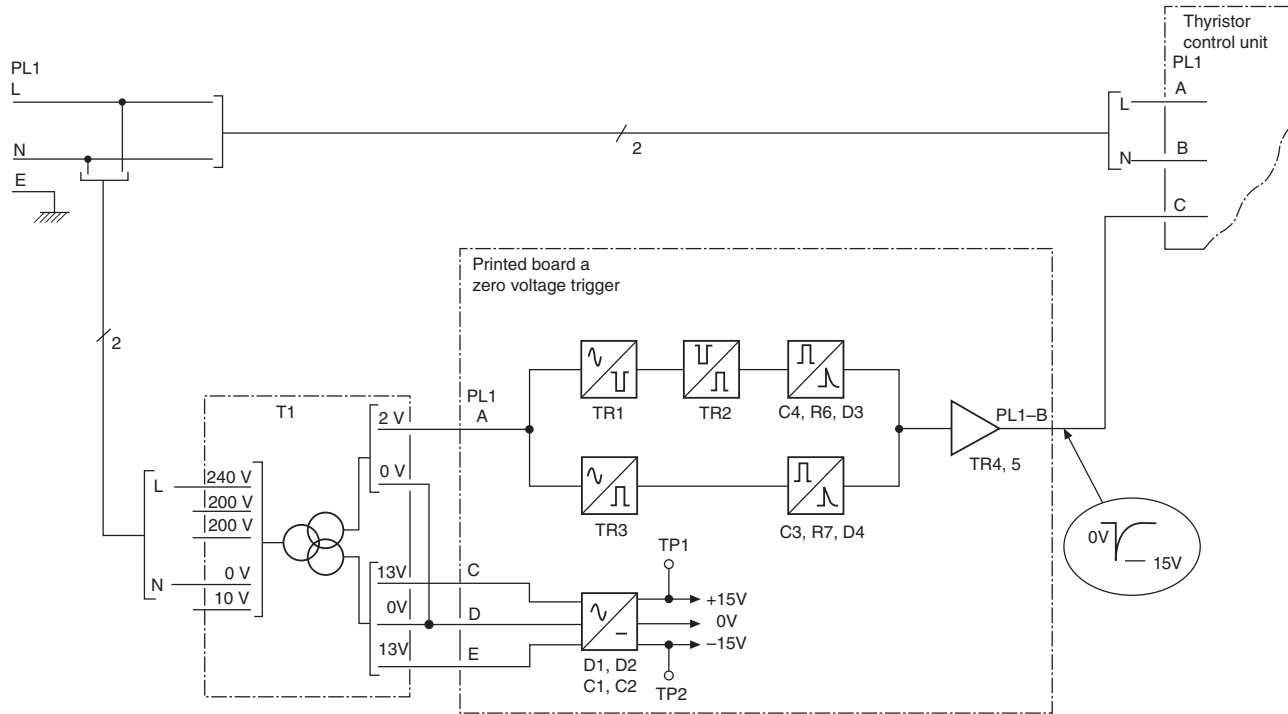
Control systems are devised to suit each individual application. Generally, each part of the system will contain air of different types. With reference to [Fig. 34.3](#) the room air (RA) is extracted by a fan, a proportion of the air is exhausted to the atmosphere and the remainder is returned and mixed with a fresh supply of air. The mixed air will then be returned to the room via a supply air fan after its temperature has been corrected to suit the design requirements.

In most cases this involves a heating operation. However, if the outside air temperature is high, or if there are considerable heat gains within the controlled space, then a cooling operation may well be necessary. In addition, full air conditioning specifications require control of the relative humidity in the space.

Personal physical comfort conditions depend on adjusting air and surface temperatures, humidity and air movement. By balancing these four factors, the engineer can design a climate to suit any type of activity.

In [Fig. 34.3](#) the air is heated by passage through a heat exchanger supplied with hot water. Hot water from a boiler operating at normal atmospheric pressure is low temperature hot water (LTHW). If the boiler operates at pressure, its output is high temperature hot water (HTHW). The heat exchanger could also be supplied with steam or operated by electricity.

The volume of outside air supplied will vary considerably with the occupancy density within the space and the activity. For example, theaters, public houses, conference rooms, areas with large solar heat gains, industrial premises with processing equipment, swimming pools and incubators, to name just a few, all require very special attention. Hence, various degrees of air purification and levels of sophistication exist. Three typical schemes now follow and [Fig. 34.4](#) shows a ventilation system. Here a controller adjusts the position of a three-way valve so that more, or less, water passes through the heat exchanger in response to supply air temperature demands. The air supplies are controlled by electrically operated dampers fitted in the ducts. Note that the air into the space has its temperature measured by the sensor fl. An alternative position for the sensor could be in the outlet duct when it could take note of any temperature increases generated within the space, or it could be positioned within the space itself, shown by u2. Many choices need to be considered.



Note. This diagram shows part of a detailed block diagram developed from the simple form of block diagram shown in (a). In this diagram functional information has been expanded and specific information in respect of input/output terminations has been added.

At this level the diagram becomes a useful diagnostic tool where input/output parameters may be monitored and hence faulty operation detected at unit, printed boards, etc. level. Maintenance at this level involves the replacement of the faulty unit or printed circuit board thus restoring normal working fairly rapidly.

Fig. 34.2b Added information.

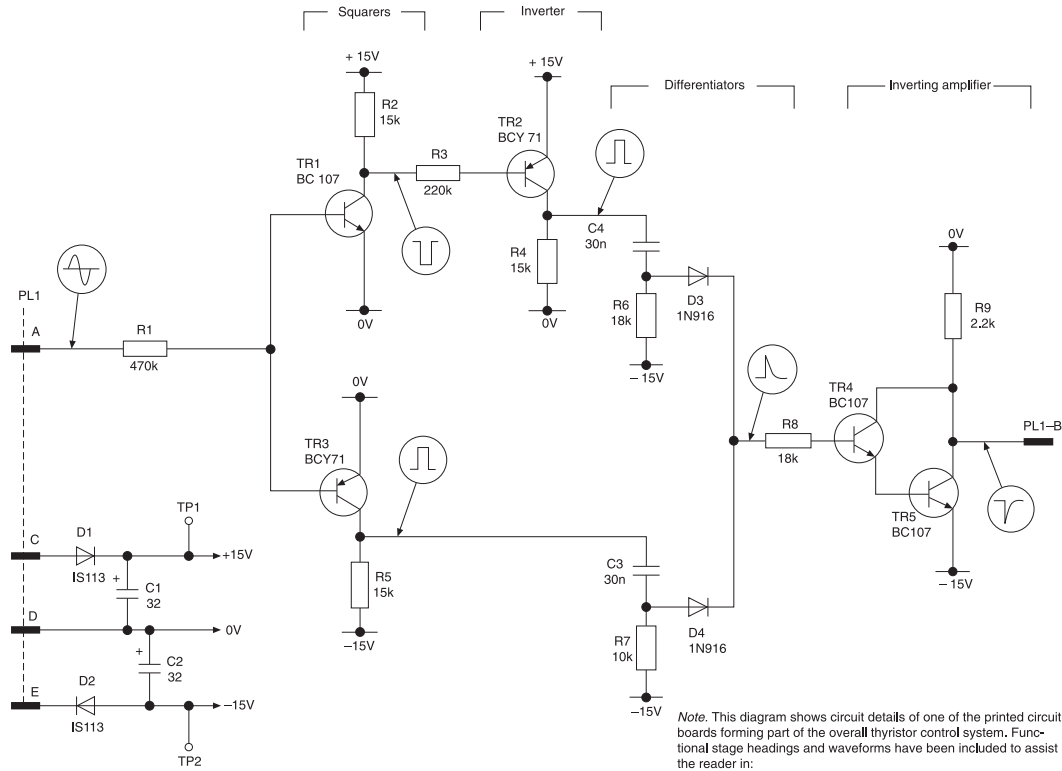
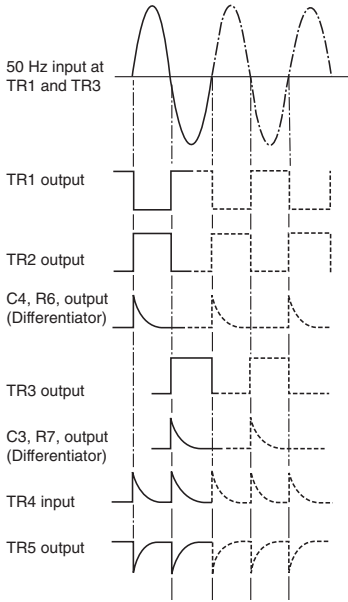
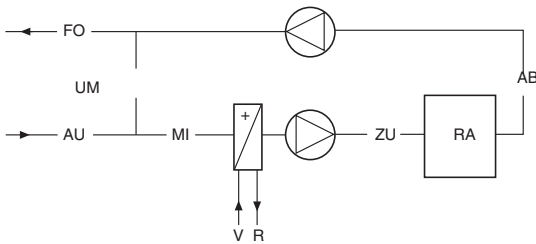


Fig. 34.2c Component connections added.



*Note.* Although the waveforms shown in (c) are of assistance to the reader in establishing that the correct signals are present at various parts of the diagram, thus assisting preliminary fault location, it does not show the timing relationship that exists between waveforms. This diagram is a supplementary diagram that defines this time relationship.

**Fig. 34.2d** Supplementary diagram.



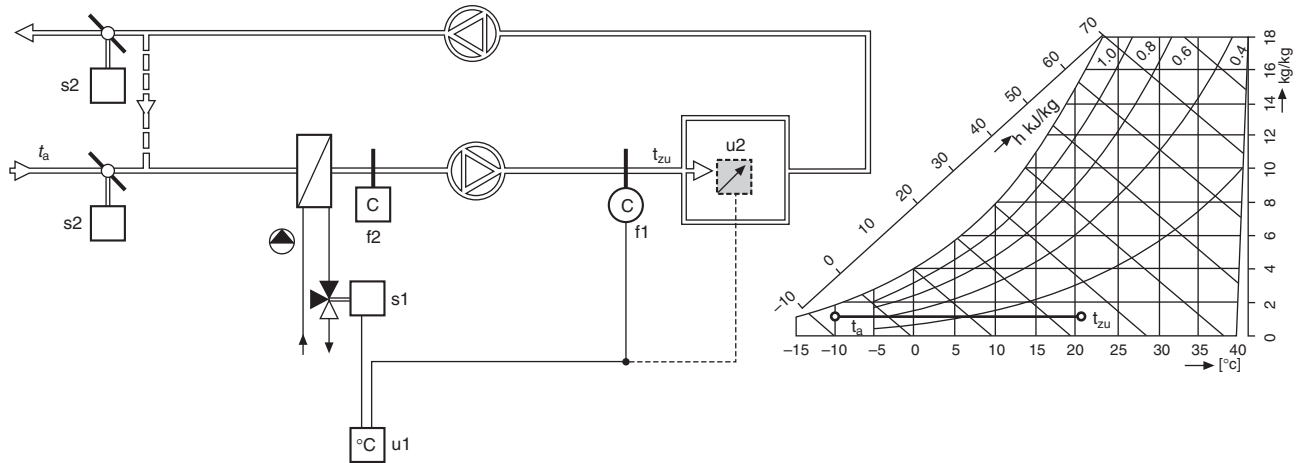
Air types: (DIN 1946).

Air type	Abbreviation
Outside air	AU
Penetrated outside air	VAU
Exhaust air	FO
Aftertreated exhaust air	NFO
Extract air	AB
Room air	RA
Aftertreated extract air	NAB
Return air	UM
Mixed air	MI
Supply air	ZU
Pretreated supply air	VZU
<hr/>	
Water:	
Flow	V
Return	R

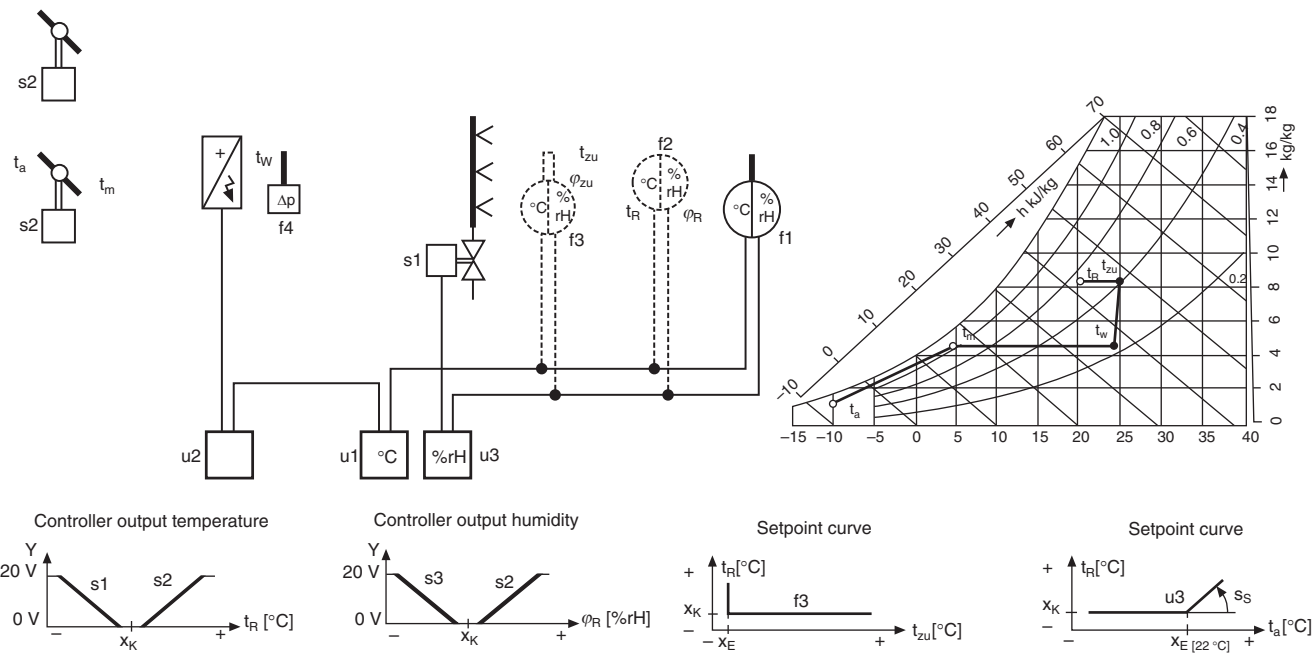
**Fig. 34.3** Example of a control system.

A scheme for partial air conditioning is illustrated in Fig. 34.5 where in addition to ventilation and heating, the humidity has been given a degree of control. For full air conditioning it is necessary to provide equipment to cool the air and typical plant has been added to the layout in Fig. 34.6.

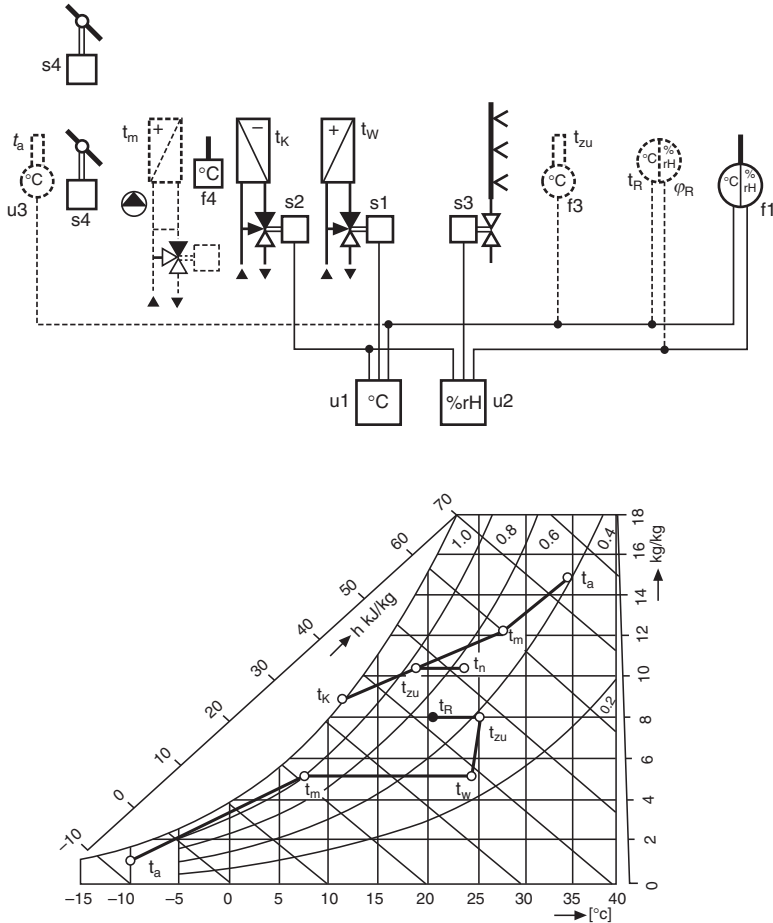
All of the installed plant needs to be carefully sized to ensure that specifications for air quality are met. The engineer uses a psychrometric chart to determine the physical properties of the air to be handled.



**Fig. 34.4** Ventilation system diagram. System designed to control the temperature of supply air into a space with heating from LTHW, HTHW or a steam heated coil. Variant with remote setpoint potentiometer.



**Fig. 34.5** Partial air conditioning system. System designed to control the extract air from a room. The air into the space is heated with an electric heating coil and humidified with steam. Alternative: room sensor instead of extract air sensor. Variant with low-limit supply air temperature control, and high-limit supply air humidity control.



**Fig. 34.6** Air conditioning system diagram. System designed to control the extract air from a room. The air into the space is heated by LTHW, HTHW or a steam heated coil. Cooling and dehumidifying with CHW cooling coil. Humidifying with steam. Alternative: room sensor instead of extract air sensor. Variants: with low-limit supply air temperature control, and with summer compensation.

**Functions**

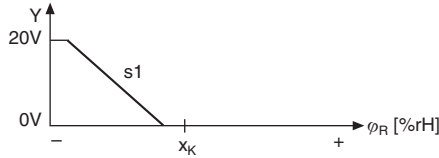
*Temperature control*

The duct sensor f1 measures the temperature  $t$ . The controller u0010 compares this value with the selected setpoint  $X$  on the controller u0010 or on the remote setpoint potentiometer u0020 and adjusts the heating coil valve s1 in accordance with the difference between the two.

## Safety devices

When there is danger of frost, the frost protection thermostat f2 must switch off the fan, close the damper s2, open the heating coil valve s1 and, where appropriate, switch on the heating pump.

## Controller output temperature



## Functions

### Temperature control

The duct sensor f1 or the room sensor f2 measures the temperature  $t$ . The controller u0010 compares this value with the selected setpoint  $X$  and adjusts the heating coil step controller (or power controller) u0020 in accordance with the difference between the two.

### Humidity control

The duct sensor f1 or the room sensor f2 measures the humidity  $\varphi$ . The controller u0030 compares this value with the selected setpoint  $X$  and adjusts the humidifying valve s1 in accordance with the difference between the two.

## Safety devices

If there is an air flow failure, the differential pressure switch f4 must cut off the control voltage of the electric heating coil. With electric heating coils, it is advisable to incorporate a timer so that the fan will run on for approximately 5 min and dissipate any residual heat.

## Functions

### Temperature control

The duct sensor f1 or the room sensor f2 measures the temperature  $t$ . The controller u0010 compares this value with the selected setpoint  $X$  and adjusts the heating coil

valve s1 or the cooling coil valve s2 in sequence in accordance with the difference between the two.

### **Humidity control**

The duct sensor f1 or the room sensor f2 measures the humidity  $\phi$ . The controller u0020 compares this value with the selected setpoint  $X$  and adjusts the humidifying value s3 or the cooling valve s2 in sequence in accordance with the difference between the two.

### **Safety devices**

When there is danger of frost, the frost protection thermostat f4 must switch off the fan, close the damper s4, open the heating coil valve s1 and, where appropriate, switch on the heating pump.

*Variant:* with low-limit supply air temperature control.

The low-limit supply air temperature sensor f3 prevents the supply air temperature  $t$  from dropping below the cut-in point  $X$  set on the controller u0010 (draught elimination).

*Variant:* with summer compensation.

The outside temperature compensation sensor u0030 is used to increase the room temperature  $t$  in summer. If the outside temperature  $t$  rises above the cut-in point  $X$  (22 °C), the setpoint  $X$  is increased continuously by the selected steepness  $S$ .

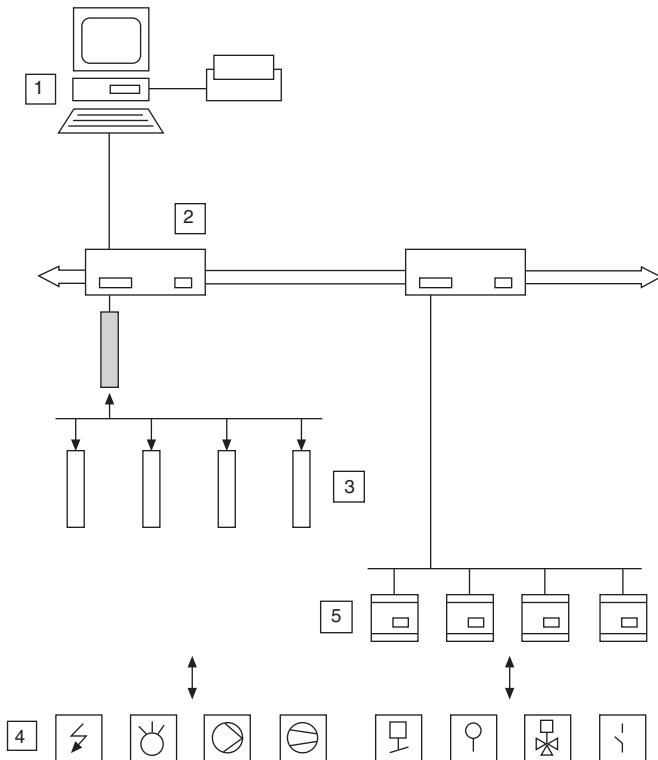
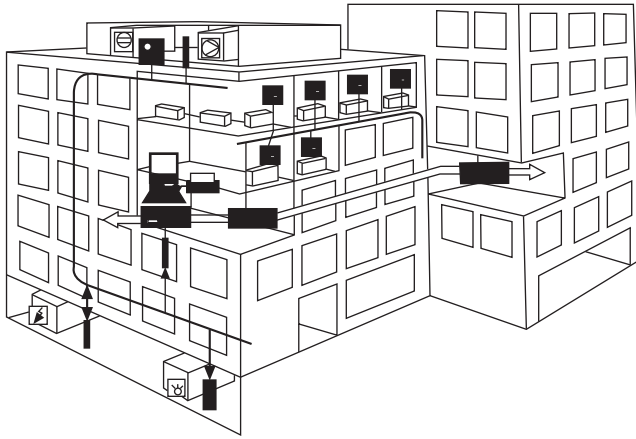
Engineer uses a psychrometric chart to determine the physical properties of the air to be handled.

### **Building management**

Figs. 34.5 and 34.6 show possible schemes for partial and full air conditioning. In addition to the controls indicated there will be all the associated ductwork, filters, water, steam, and electrical services. An electrical control panel is usually necessary for the wiring of interconnected equipment, instrumentation, and to isolate plant for servicing. Although operations are generally fully automatic, emergency hand control facilities are often specified.

In an industrial situation where many departments exist under the one roof, a central building management system is necessary if the plant engineer requires to know what is happening in the installation at any time.

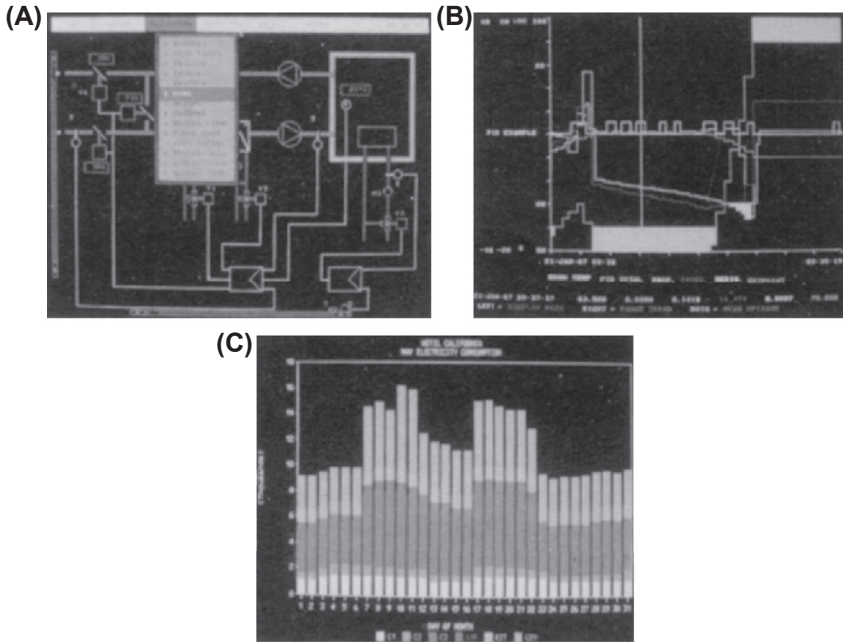
Fig. 34.7 shows a diagrammatic arrangement of a building management system with software designed specifically for the installation. Control can be by a PC (item 1) or laptop.



**Fig. 34.7** Diagrammatic arrangement of a building management system.

The operator can check how any of the peripheral components (4) are working. Control units for major items of equipment such as boilers and fans are shown as item (3). Individual room controllers (5) control energy consumption as a function of room occupancy, the time of day and season. System controllers (2) coordinate process control tasks such as the overall management of energy.

The plant manager has instant access to data using a mouse operation and pull down menus. Individual schematic diagrams can be displayed. Recorded data over a period of time can be displayed or printed out (Fig. 34.8).



**Fig. 34.8** Typical displays. (A) Pull down menus for selecting functions relating to any schematic in the building layout. (B) Pictorial graph of control operations with shaded bands where limit values have been exceeded. (C) Data evaluation and display. Electricity consumption in various zones for one month is given in this example.

### **The psychrometric chart (Fig. 34.9)**

In air conditioning technology, it is necessary to define thermodynamic processes and the properties of moist air.

This may be achieved by a good knowledge of physics, with theoretical calculations using complicated formulae and tables. The procedure can be time consuming.

By presenting the interrelated factors on a psychrometric chart, an immediate decision can be made regarding the feasibility of controlling an air conditioning system and the means required to carry this out.

For a given air sample nine different parameters are shown on the psychrometric chart.

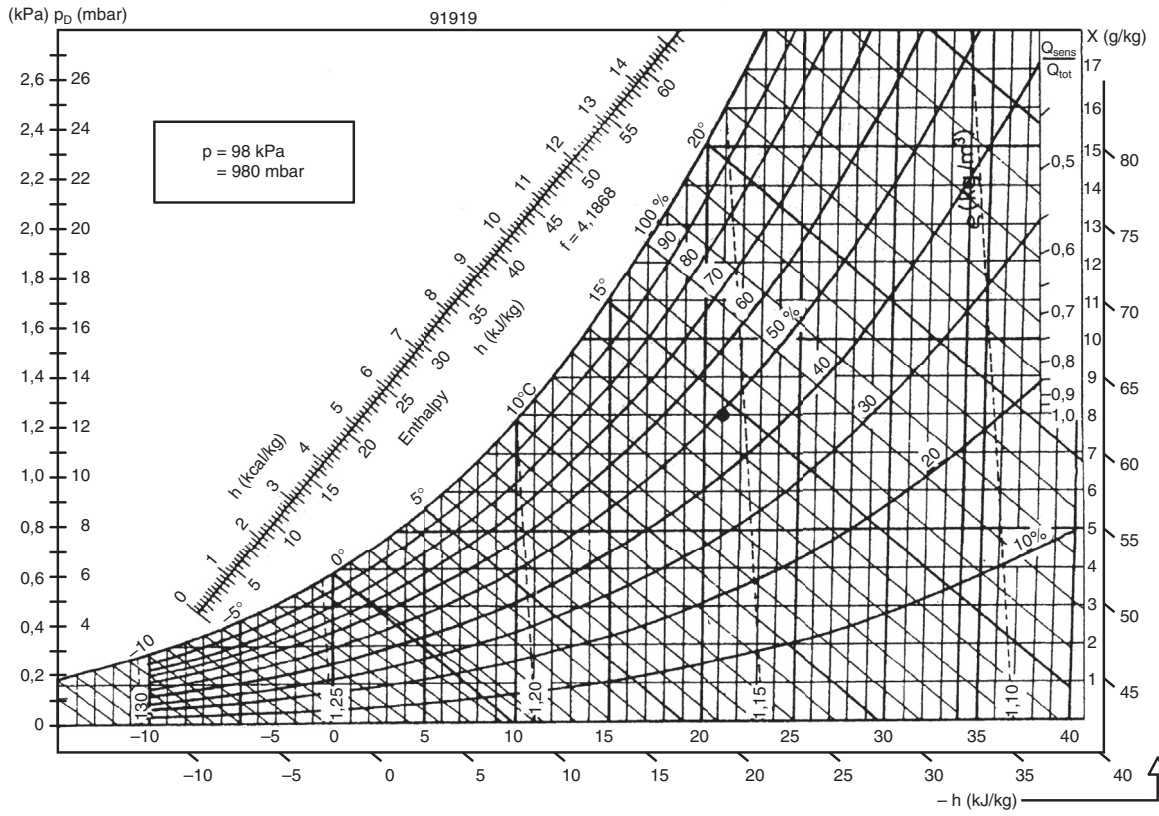


Fig. 34.9 Psychrometric chart.

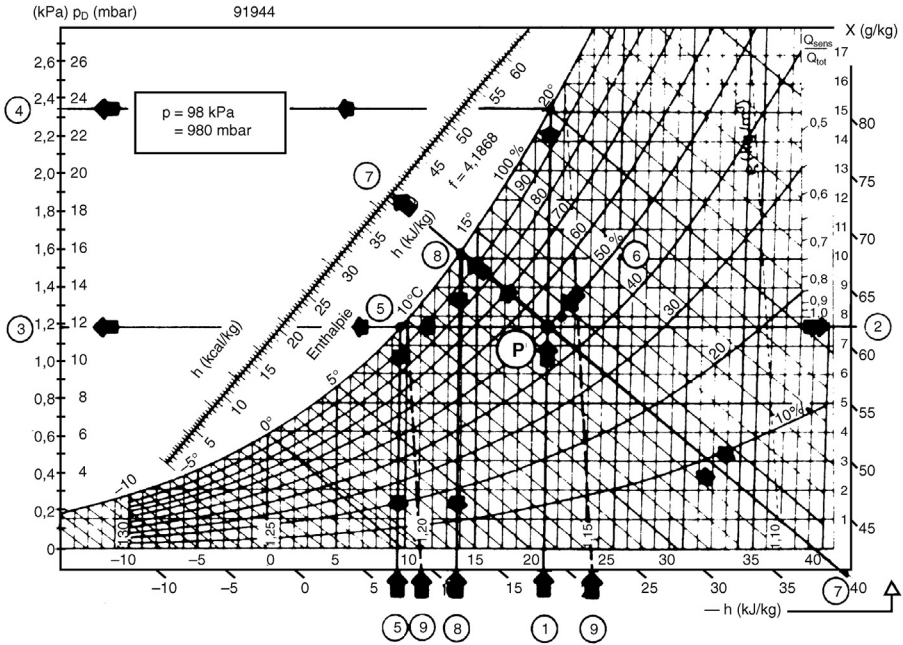


Fig. 34.10 Solution - Psychrometric chart.

A position on the chart can be established at the intersection of two ordinates for known conditions and the others obtained.

Since the properties and behavior of moist air depend on barometric pressure, a psychrometric chart can only be drawn for a specific barometric pressure. Allowances may be made for changes in barometric pressure by using correction factors.

Note that the chart indicates a condition of 21 °C dry bulb temperature and 48% relative humidity. These are typical values to provide comfort in an office.

Example: Find the missing values for the following case (see Fig. 34.9).

1. Dry bulb temperature  $t = 20 \text{ }^\circ\text{C}$
2. Absolute humidity  $x = \text{g/kg}$
3. Partial water vapor pressure  $P = \text{mbar or kPa}$
4. Saturation pressure  $P = \text{mbar or kPa}$
5. Saturation temperature (dew point)  $t = \text{ }^\circ\text{C}$
6. Relative humidity  $\varphi = 50\%$
7. Enthalpy  $h = \text{kJ/kg}$
8. Wet bulb temperature  $t = \text{ }^\circ\text{C}$
9. Density  $\rho = \text{kg/m}^3$

The point on the chart is defined by the temperature and the relative humidity given above.

Solution - see Fig. 34.9.

The point of intersection  $P$  between the  $20\text{ }^\circ\text{C}$  isotherm from the dry bulb temperature (1) and the line of 50% constant relative humidity (6) clearly defines the position of the required condition.

The absolute humidity (2) is found by drawing a horizontal line through the point  $P$  and extending it until it meets the ordinate on the right.

If this horizontal is extended to the left it will intersect the scale for partial water vapor pressure  $p$  (3).

To obtain the saturation pressure (4) the isotherm from  $P$  must be extended until it intersects the 100% relative humidity line. At this point the air is saturated, i.e. it cannot absorb any further moisture without a dense mist forming. An extension of the horizontal line through this point of intersection to the left intersects the partial pressure scale at point (4). The pressure of the saturated air can now be read.

Where the horizontal line from ( $P$ ) intersects the saturation curve a similar condition occurs, whereby the air cannot absorb any additional moisture (5). The dew point or saturation temperature can now be read on the saturation curve (and also on the dry bulb temperature scale).

By following the isenthalp (line of constant enthalpy) which passes through condition ( $P$ ) we can determine the enthalpy at the points of intersection (7) with the enthalpy scale. If an adiabatic line is drawn through the point ( $P$ ) toward the saturation curve, the two intersect at point (8) to give the wet bulb temperature. This is lower than the starting temperature because the absorption of moisture has caused sensible heat to be converted into latent heat.

The density is determined from the nearest broken lines of constant density (9).

The required values are:

2.	$\times$	= 7.65	g/kg
3.	$P$	= 11.8	mbar = 1.18 kPa
4.	$P$	= 23.4	mbar = 2.34 kPa
5.	$t$	= 9.6	$^\circ\text{C}$
7.	$H$	= 39.8	kJ/kg
8.	$t$	= 13.8	$^\circ\text{C}$
9.	$P$	= 1.16	kg/m <sup>3</sup>

## Refrigeration systems and energy-saving applications

In order to appreciate the engineering diagram examples relating to refrigeration practice, we have included an explanation of a typical cycle of operations.

## ***Refrigeration through evaporation***

When you pour liquid ether on to the back of your hand, after a few seconds you feel your hand turn ice-cold. The liquid evaporates very quickly, but in order to do so it requires heat — so-called heat of evaporation. This heat is drawn in from all around the ether — including from your hand — and it is this which causes a sensation of cold.

If you could catch this evaporated ether and liquefy it again by compressing and cooling, the heat absorbed during evaporation would be released back into the surroundings.

This is precisely the principle on which the refrigeration cycle works. A special refrigeration agent, which is even more suitable for this purpose than ether, is evaporated close to the medium to be refrigerated. The heat necessary for this process is drawn in from all around, thereby cooling the air or water.

The most widely known refrigerating agent used to be ammonia but this has now been almost entirely superseded by halogen refrigerants, the best known of which are R12, R22, and R502.

## ***The refrigerant cycle***

The refrigerant circulates in a closed system. To produce this circulation, a very powerful pump is required — the compressor. This draws in the expanded refrigerant in vapor form and compresses it. On being compressed, the temperature of the vapor rises. It moves on to the condenser and is cooled by means of cold water. The cooling is so great that the condensation temperature is reached and the condensation heat thus produced is given up to the water in the condenser.

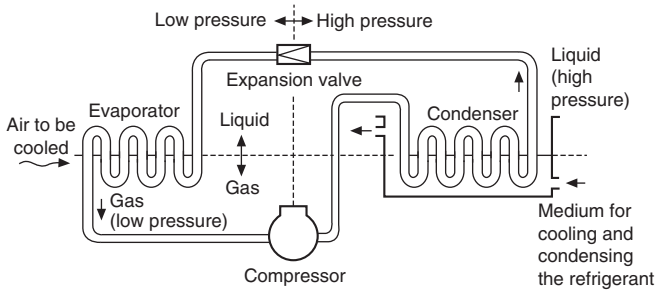
The refrigerant is then pumped on in liquid form into a receiver and from there on to the evaporator. But just before this, it flows through an expansion valve. This valve reduces the pressure on the liquid so much that it evaporates, drawing in the required heat from its surroundings. This is precisely as intended for the air or water to be cooled and it is led past the group of pipes in the evaporator. After leaving the evaporator, the refrigerant is once again drawn into the compressor.

To summarize: in one-half of the cycle, the heat is removed by evaporation (i.e. cooled where cooling is required) and in the other half heat has been released by condensing. Thus energy (heat) is moved from where it is not wanted to a (different) place where it is tolerated or, in fact, required.

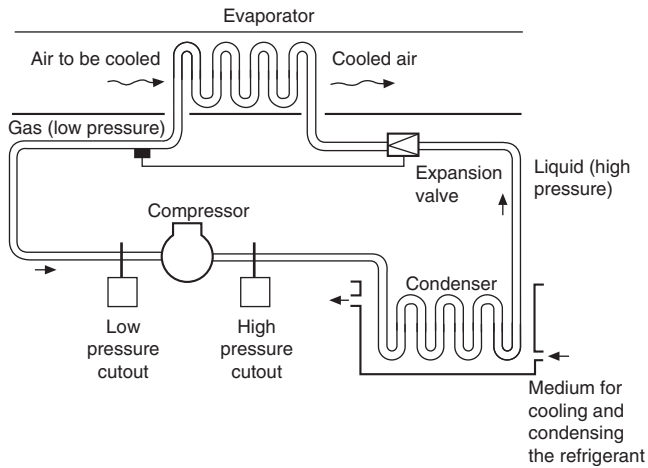
When the theoretical cycle of operations is applied in practice it is necessary to include controls and safety devices. In a domestic system, the motor and compressor are manufactured in a sealed housing.

The heat extracted from the inside of the refrigerator, where the evaporator is positioned, passes to the condenser, generally at the back of the cabinet, where natural convection currents release the heat into the surroundings.

In a large industrial installation it may be economically viable to recover heat from a condenser and use it for another process (Figs. 34.11–34.12).



**Fig. 34.11** The refrigerant cycle.



**Fig. 34.12** The safety devices in the refrigerant cycle.

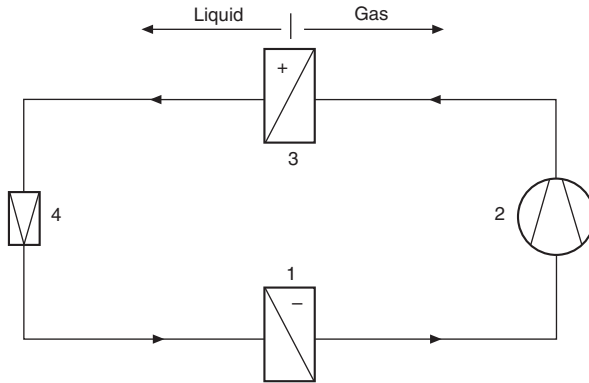
### ***Heat recovery control in refrigeration systems***

The principle of the refrigeration cycle is shown in Fig. 34.13, where the refrigerant passes through the following four phases:

1. evaporation (with heat absorption);
2. compression (with energy absorption);
3. condensation (with heat emission);
4. expansion.

In a refrigeration system, a second condenser can be incorporated in the cycle and the recovered heat used for:

1. heating domestic water;
2. supply air heating;
3. reheating in the case of supply air dehumidification.



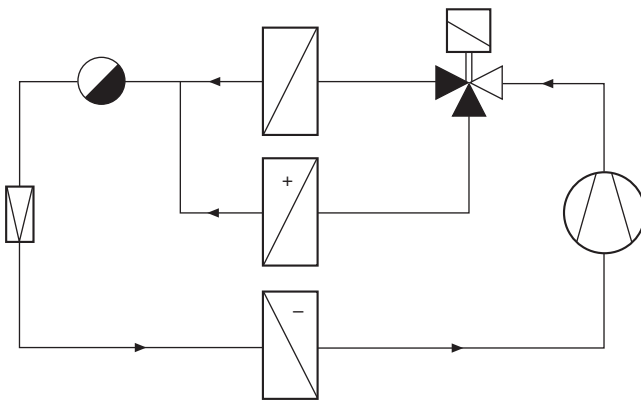
**Fig. 34.13** Four stages of a refrigeration cycle.

**Control options**

The heat absorbed by the evaporator and that generated by the compressor are emitted in the condenser. To recover this heat an additional condenser can be connected in parallel, and alternative positions of a three-way valve give two options: ‘hot gas diversion’ or ‘condensate control’.

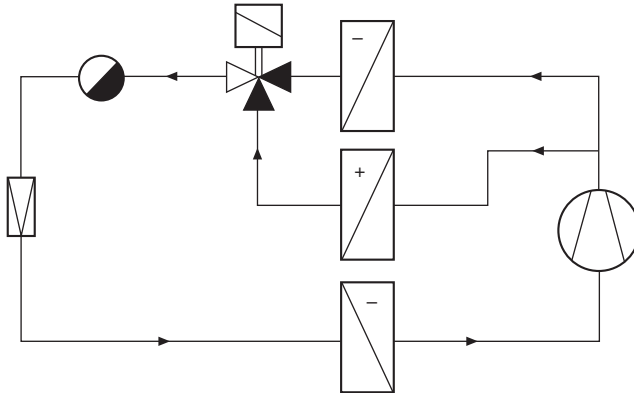
Fig. 34.14 shows the second condenser fed from a three-way diverting valve installed in the hot gas pipe to illustrate hot gas diversion.

*Option 1:* When the controller transmits a demand for heating (e.g. via the supply air temperature in the air conditioning system), the modulating diverting valve opens the flow to the heat recovery condenser and closes the supply to the other condenser. If not all the heat recovered is required, the remainder is dissipated via the second condenser.



**Fig. 34.14** Heat recovery using two condensers.

Fig. 34.15 shows the connections for condensate control with the three-way value positioned in the liquid pipe.



**Fig. 34.15** Condensate control connections.

*Option 2:* The entire refrigerant flow is normally directed through the valve (see Fig. 34.15). The three-way liquid valve opens the condensate pipe of the heat recovery condenser and closes the pipe of the second condenser when the heat recovery condenser has to emit effective heat. This condenser then releases all condensate thus making its heat exchange surface free for condensation of fresh hot gas. At the same time, the second condenser is filled with liquid thus making its exchange surface inactive. When the demand for effective heat decreases, the process is reversed.

The following examples show how the two options have been applied in a swimming pool/ice rink and a covered shopping complex.

The system shown in Fig. 34.16 relates to an air conditioning system in an indoor swimming pool combined with a low-temperature refrigeration system for an ice rink. It is designed on the principle of the schematic in Fig. 34.14 (hot gas diversion) in order to provide a fast response time of the supply air control.

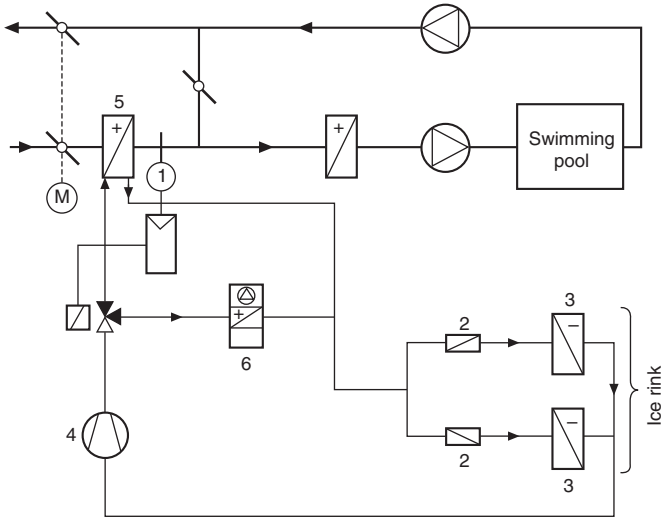
Indoor swimming pools normally require large quantities of heat and have high-relative humidity. If cold outside air is mixed with the humid return air, condensation results. To avoid this, the outside air is preheated by a heat recovery condenser (5) (Fig. 34.17).

Systems installed in enclosed shopping complexes have the following characteristics:

- large heat demand for air conditioning of shopping street;
- large heat output from refrigerated cabinets.

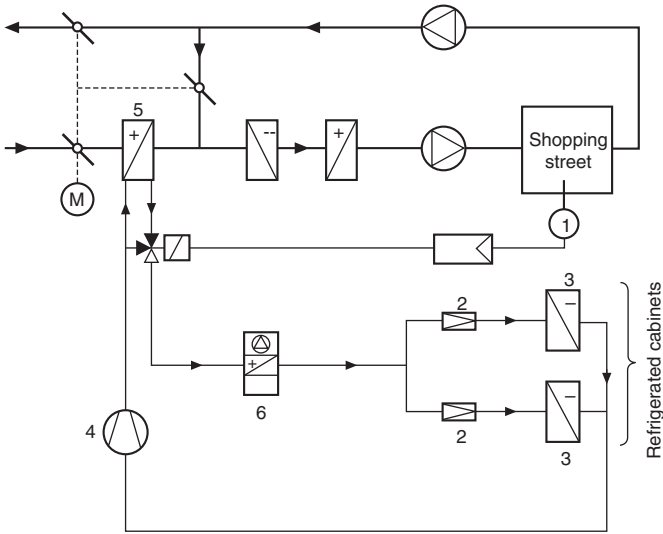
The two condensers in the system illustrated are connected in series. The heat recovery condenser (5) can be switched off completely in summer. In winter, spring and autumn it is used to pre-heat the outside in accordance with demand (Fig. 34.18).

The authors wish to express their thanks for the assistance given and permission to include examples of applications engineered by Staefa Control System Ltd – [www.staefacontrol.com](http://www.staefacontrol.com).



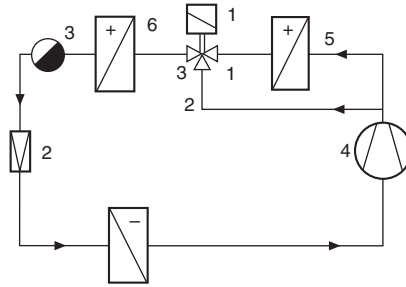
- Key
- 1 Control valve
  - 2 Expansion valve
  - 3 Evaporator
  - 4 Compressor
  - 5 Heat recovery condenser
  - 6 Outside condenser

**Fig. 34.16** Indoor swimming pool/ice rink.



- Key
- 1 Control valve
  - 2 Expansion valve
  - 3 Evaporator
  - 4 Compressor
  - 5 Heat recovery condenser
  - 6 Outside condenser

**Fig. 34.17** Air conditioning and refrigeration system in an enclosed shopping complex.



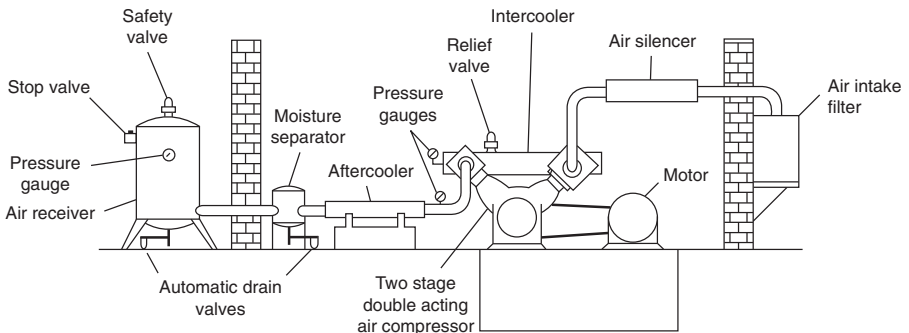
- Key**
- |                   |                           |
|-------------------|---------------------------|
| 1 Control valve   | 4 Compressor              |
| 2 Expansion valve | 5 Heat recovery condenser |
| 3 Evaporator      | 6 Outside condenser       |

**Fig. 34.18** Refrigeration cycle of the shopping complex (simplified).

## Pneumatic systems

Pneumatic systems require a supply of clean compressed air to motivate cylinders, tools, valve gear, instruments, delicate air controls and other equipment. Most factory and plant installations operate between 5.5 and 7 bar.

A typical compressor installation is shown in [Fig. 34.19](#).



**Fig. 34.19** Typical compressor installation.

Compressors are sized according to the amount of free air delivered. Air flow is measured in cubic decimetres per second ( $\text{dm}^3/\text{s}$ ) at standard atmospheric conditions of 1013 mbar and  $20^\circ\text{C}$  as specified in ISO 554. The compressed air is stored in an air receiver and, for a system operating at pressures in the region of 7 bar gauge, the size of the receiver in liters should be approximately equal to 30 times the rated free air delivery of the compressor in  $\text{dm}^3/\text{s}$ . Thus, a compressor rated at  $50 \text{ dm}^3/\text{s}$  free air delivery requires a receiver of approximately 1500 L capacity.

Compressed air in any normal supply mains contains contaminants which need to be either completely or partially removed depending on the ultimate use of the

compressed air. Naturally, the cleaner the air has to be, the greater the expense. The contaminants are:

- a. water in liquid and vapor form;
- b. oil which can exist in three forms, i.e. oil/water emulsions, minute droplets suspended in the air as an aerosol, and oil vapors;
- c. atmospheric dirt particles and solid particles formed by the heat of compression.

Having considered the types of contaminant present in an air system, one can decide upon the degree of cleanliness needed for any particular process and the means required to obtain it. This includes after-coolers, receivers, air line filters, air dryers, coalescing filters, vapor adsorbers, and ultra high-efficiency dirt filters. Each application must be considered on its merits. Fig. 34.20 shows a typical air line installation for a factory. Further cooling may occur in the distribution mains themselves; these should be installed with a pitch in the direction of the air flow, so that both gravity and air flow will carry water to drain legs at appropriate intervals. These legs should be fitted with automatic drain valves. Note that take-off points are connected to the top of the distribution mains to prevent water entering the take-off lines.

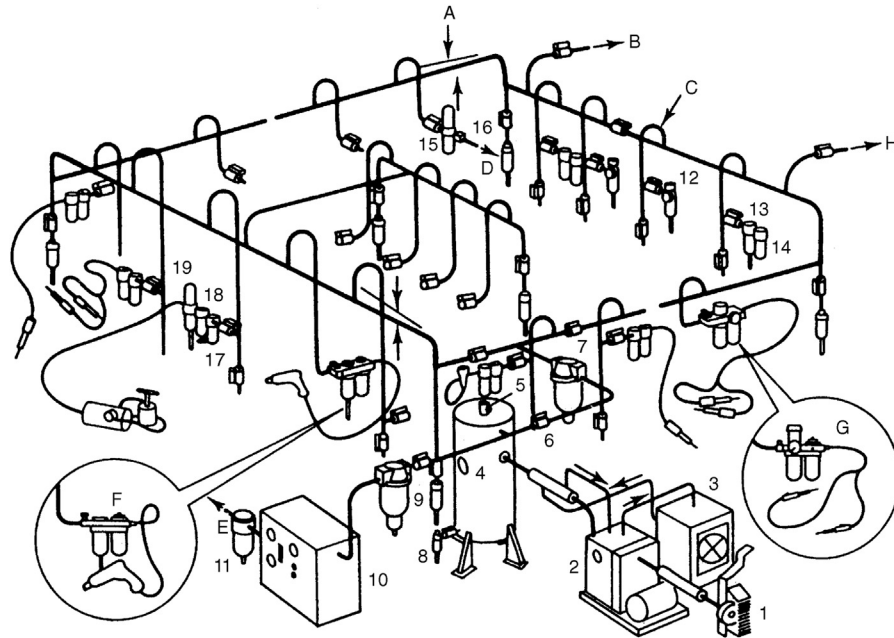
The quality of air required for plant use will now dictate which accessories are to be fitted at each take off point. These range from a selection of filters to pressure regulators; and if lubrication is required in air actuated components, then lubricant can be metered and atomized in the air line in the form of a fine fog to coat all operating parts with a thin protective film. The equipment is lubricated automatically through its operating cycle.

Regular maintenance will ensure trouble-free production facilities.

Industrial processes include: air agitation, air bearings, air conveying of foodstuffs and powders, air motors, i.e. rotary, reciprocating and linear air cylinders, blow guns, cleaning and cooling nozzles, breathing masks and protective clothing, fluidics, food and drink processing, general machinery, instrumentation, pneumatic circuits and valves, and spray guns. and the common symbols used in pneumatic circuits are shown in Table 34.2.

### ***Pneumatic circuit design***

The first requirement in circuit design is a thorough understanding of the symbols to be used. The most important and frequently used symbols are the five-port and three-port valves. They are also the most frequently misunderstood symbols, and therefore we start by showing the build-up of a typical five-port valve. In Fig. 34.21 a double-acting cylinder is shown connected to a five-port valve. The square envelope represents the valve body and there are three ports on the bottom edge and two on the top edge. A compressed air supply is connected to the center port 1. Air exhausts to atmosphere at ports 3 and 5. Air outlets to power the cylinder at ports 2 and 4. The lines within the envelope show the passages within the valve for the current valve state. The air supply 1 is connected to outlet 4 and outlet 2 is connected to exhaust 3. Exhaust 5 is sealed. This means that the cylinder has air pressure pushing the piston to the instroked or 'minus' position. The other side of the piston is connected to exhaust.



- |   |  |
|---|--|
| 1. Air intake filter                          | 17. Primary filter*                      |
| 2. Air compressor                             | 18. Precision regulator*                 |
| 3. Air compressor water to air heat exchanger | 19. 'Ultraire' filter                    |
| 4. Air receiver                               | A. Pitch with flow                       |
| 5. Safety valve                               | B. To machine shop                       |
| 6. Isolating valve                            | C. Wide pattern return bends             |
| 7. Main line air filter                       | D. To gauging equipment                  |
| 8. Automatic air receiver drain               | E. Dry air to process control            |
| 9. Drip-leg drain                             | F. Olympian 'plug-in' Vitalizer unit     |
| 10. Dryer                                     | G. Olympian 'plug-in' lubro-control unit |
| 11. 'Puraire' after-filter                    | H. To future extensions                  |
| 12. Filter-regulator                          |  |
| 13. Automatic drain filter                    |  |
| 14. Lubricator                                |  |
| 15. 'Ultraire' filter*                        |  |
| 16. Precision controller*                     |  |
- \*Precision air sets

Fig. 34.20 Typical air line installation.

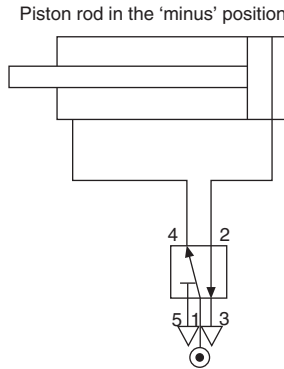


Fig. 34.21 Double acting cylinder with five port valve.

Table 34.2 Common symbols used on pneumatic diagrams.

Description	Symbol	Description	Symbol	Description	Symbol
General symbols		Air-oil actuator (transforms pneumatic pressure into a substantially equal hydraulic pressure or vice versa)		spring loaded (opens if the inlet pressure is greater than the outlet pressure and the spring pressure)	
Basic symbols		Directional control valves		pilot controlled (opens if the inlet pressure is higher than the outlet pressure but by pilot control it is possible to prevent:	
Restriction:		Flow paths:		closing of the valve	
affected by viscosity		one flow path		opening of the valve	
unaffected by viscosity		two closed ports		with restriction (allows free flow in one direction but restricted flow in the other)	
Functional symbols		two flow paths			
hydraulic flow		two flow paths and one closed port			
pneumatic flow or exhaust to atmosphere		two flow paths with cross connection			
Energy conversion		one flow path in a by-pass position, two closed ports			
Pumps and compressors		Directional control valve 2/2:			
Fixed capacity hydraulic pump:		with manual control		Shuttle valve (the inlet port connected to the higher pressure is automatically connected to the outlet port while the other inlet port is closed)	
with one direction of flow		controlled by pressure against a return spring		Pressure control valves	
with two directions of flow		Direction control valve 5/2:		Pressure control valve:	
Motors		controlled by pressure in both directions		one throttling orifice normally closed	
Fixed capacity hydraulic motor:				one throttling orifice normally open	
with one direction of flow		Non-return valves, shuttle valve, rapid exhaust valve		two throttling orifices normally closed	
Oscillating motor:		Non-return valve:		Sequence valve (when the inlet pressure overcomes the spring, the valve opens, permitting flow from the outlet port)	
hydraulic		free (opens if the inlet pressure is higher than the outlet pressure)			
Cylinders					
Single acting:	Detailed				
returned by an unspecified force	Simplified				
Double acting:					
with single piston rod	Detailed				
Cylinder with cushion:					
Single fixed					

**Table 34.2** Common symbols used on pneumatic diagrams.—cont'd

Description	Symbol	Description	Symbol	Description	Symbol
<b>Flow control valves</b>					
Throttle valve: simplified symbol		Rotary connection		Over-centre device (prevents stopping in a dead centre position)	
Example: braking valve		one way		Pivoting devices: simple	
Flow control valve (variations in inlet pressure do not affect the rate of flow):	*Simplified	three way		with traversing lever	
with fixed output		<b>Reservoirs</b>		with fixed fulcrum	
Flow dividing valve (divided into a fixed ratio substantially independent of pressure variations)		Reservoir open to atmosphere:		<b>Control methods</b>	
<b>Energy transmission and conditioning</b>					
<b>Sources of energy</b>					
Pressure source		with inlet pipe above fluid level		Muscular control:	
Electric motor		with inlet pipe below fluid level		general symbol	
Heat engine		with a header line		by push-button	
<b>Accumulators</b>					
		Pressurized reservoir		by lever	
		The fluid is maintained under pressure by a spring, weight or compressed gas		by pedal	
<b>Flow line and connections</b>					
		Filters, water traps, lubricators and miscellaneous apparatus		Mechanical control:	
Flow line:		Filter or strainer		by plunger or tracer	
working line, return line and feed line		Heat exchangers		by spring	
pilot control line		Temperature controller (arrows indicate that heat may be either introduced or dissipated)		by roller	
drain or bleed line		Cooler (arrows indicate the extraction of heat)		by roller, operating in one direction only	
flexible pipe		with representation of the flow lines of the coolant		Electrical control:	
Pipeline junction		Heater (arrows indicate the introduction of heat)		by solenoid (one winding)	
Crossed pipelines (not connected)		Control mechanisms		by electric motor	
Air bleed		Mechanical components		Control by application or release of pressure	
Power take-off		Rotating shaft:		Direct acting control:	
plugged		in one direction		by application of pressure	
with take-off line		in either direction		by release of pressure	
connected, with mechanically opened non-return valves		Detent (device for maintaining a given position)		Combined control:	
uncoupled, with open end		Locking device (*symbol for unlocking control)		by solenoid and pilot directional valve (pilot directional valve is actuated by the solenoid)	
uncoupled, closed by free non-return valve				Measuring instruments	
<b>Control mechanisms</b>					
<b>Pressure measurement:</b>					
pressure gauge					
<b>Other apparatus</b>					
Pressure electric switch					

Note 1: The symbols for hydraulic and pneumatic equipment and accessories are functional and consist of one or more basic symbols and in general of one or more functional symbols. The symbols are neither to scale nor in general orientated in any particular direction.

Note 2: In circuit diagrams, hydraulic and pneumatic units are normally shown in the unoperated position.

Note 3: The symbols show connections, flow paths and the functions of the components, but do not include constructional details. The physical location of control elements on actual components is not illustrated.

To make the cylinder move to the outstroked or ‘plus’ position the valve has to be operated to change to its new state. This is shown in Fig. 34.22. Note that the envelope and port connections are exactly the same and it is only the connection paths inside the valve that have changed.

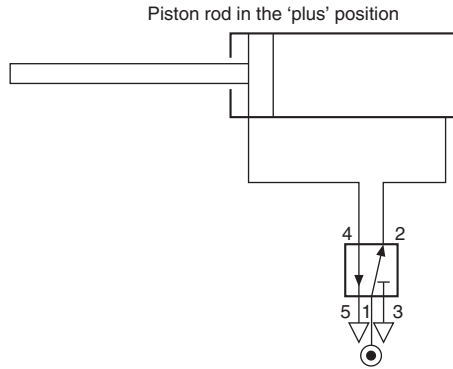


Fig. 34.22 Double acting cylinder with five port valve.

The full symbol for a 5/2 valve (five ports, two positions) are these two diagrams drawn alongside each other. Only one-half will have the ports connected.

Which half will depend on whether the cylinder is to be drawn in the instroked or outstroked state. The method by which the valve is operated, push button, lever, foot pedal, etc. is shown against the diagram of the state that it produces.

Fig. 34.23 shows a 5/2 push button operated valve with spring return. It is operating a double acting cylinder. In addition a pair of one-way flow regulators are included to control the speed of piston rod movement. The symbol for this type of flow regulator consists of a restrictor, an ‘arrow’ which indicates it is adjustable and a non-return valve in parallel, to cause restriction in one direction only. The conventional way to control the speed of a cylinder is to restrict the exhausting air. This allows full power to be developed on the driving side of the piston which can then work against the back pressure and any load presented to the piston rod.

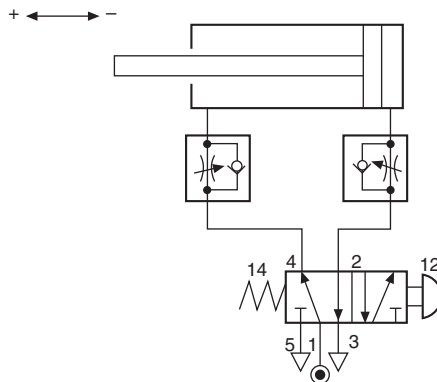
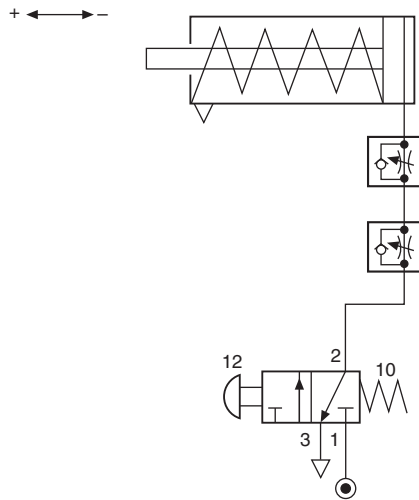


Fig. 34.23 Double acting cylinder with push button valve.

Study Fig. 34.24 and imagine that when the push button is pressed the complete symbol moves sideways to the left, but leaves the pipe connections and port numbers behind so that they line up with the other half of the diagram. In this position the cylinder piston rod will move out to the 'plus' position. Imagine the spring pushing the symbol back again when the button is released. The numbers at the valve ends signify which output will be pressurized when the valve is operated at that end. If the button is pushed at end 12 then port 1 will be connected to port 2.

If the button is released, the spring at end 14 becomes dominant and port 1 will be connected to port 4.

A three-port valve symbol works in a similar way. Two diagrams of the valve are drawn side by side. Fig. 34.24 shows the full symbol for a 3/2 valve controlling a single acting cylinder. Port 1 is the normal inlet, port 2 the outlet and port 3 the exhaust. The valve end numbers 12 and 10 indicate that port 1 will be connected either to 2 or to 0 (nothing). Since there is only one pipe supplying a single-acting cylinder, speed control of the 'plus' motion has to be obtained by restricting the air into the cylinder. Speed control of the 'minus' motion is effected conventionally by restricting the exhausting air. To provide independent adjustment two one-way flow regulators are used and these are connected in the line back-to-back.

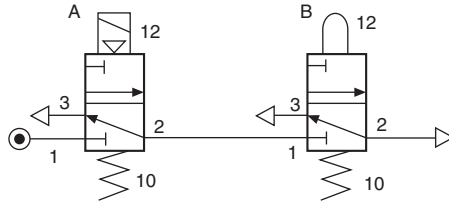


**Fig. 34.24** Single acting valve controlled by a 3/2 valve.

### Logic functions

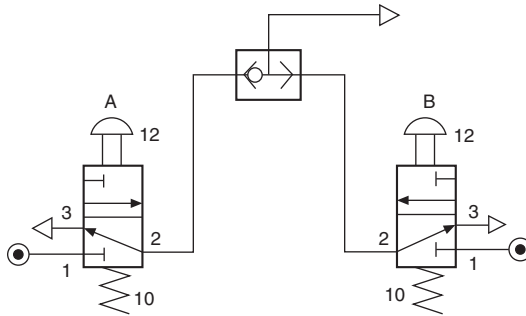
Designers of pneumatic circuits are not usually consciously thinking in pure logic terms, but more likely designing intuitively from experience and knowledge of the result that is to be achieved. Any circuit can be analyzed, however, to show that it is made up of a combination of logic functions. The four most commonly used are illustrated in Figs. 34.25–34.33.

*The AND function:* The solenoid valve A (AND) the plunger operated valve B must both be operated before an output is given at port 2 of valve B (Fig. 34.25).



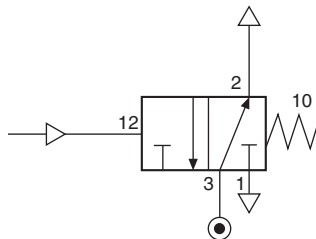
**Fig. 34.25** The 'AND' function.

*The OR function:* For this a shuttle valve is required so that either of two push-button valves A (OR) B can provide a signal that is directed to the same destination. The shuttle valve contains a sealing element that is blown by the incoming signal to block off the path back through the other valve's exhaust port (Fig. 34.26).



**Fig. 34.26** The 'OR' function.

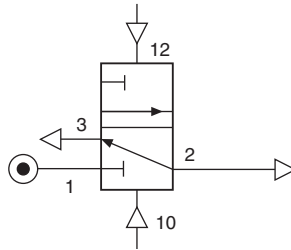
*The NOT function:* This is simply a normally open valve. When it is operated by a pilot signal on port 12 it will NOT give an output. The outlet will be given when the valve re-sets to its normal state by removing the signal (Fig. 34.27).



**Fig. 34.27** The 'NOT' function.

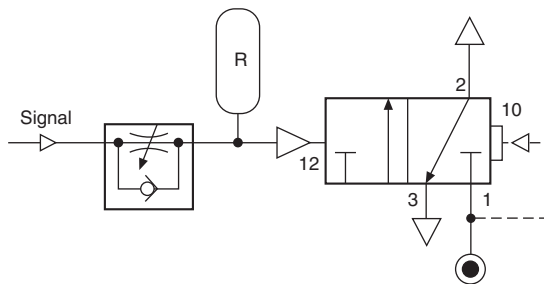
*The MEMORY function:* When a double pressure operated three-port valve is given a signal at port 12, an output is obtained at port 2. If the signal is now removed the output will remain; it has REMEMBERED its ON state even when the signal that caused it has gone.

If a signal is given to port 10 the valve will re-set and the output exhausted. If the signal is removed the new OFF state is REMEMBERED (Fig. 34.28).



**Fig. 34.28** The 'MEMORY' function.

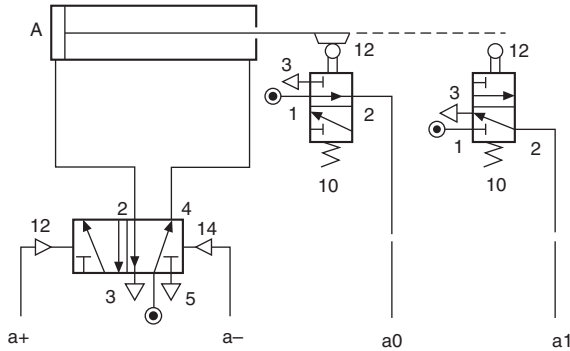
*The TIME DELAY:* By using a flow regulator and a 3/2 pilot operated pressure switch, a signal can be slowed down to provide a time delay. Fig. 34.29 shows that when a signal is fed through the flow regulator, it will slowly build up pressure in an air reservoir (R) and on the signal port 12 of the pressure switch. This will continue until the pressure is high enough to operate the pressure switch. Then, a strong unrestricted signal will be sent to operate a control valve or other device. The delay can be adjusted by changing the setting on the flow regulator. A reservoir, of approximately 100 cc in volume, would allow a delay range of between 2 and 30 s. Without the reservoir, the range will be reduced to approximately 3 s maximum. Note that the pressure switch is like a pilot operated 3/2 valve, but uses air pressure as a return spring. The pilot signal on port 12 overcomes this, as it is working on a larger area piston.



**Fig. 34.29** The 'TIME DELAY'.

A semi-automatic circuit is shown in Fig. 34.30. When the push button is operated and released, the 3/2 valve will send a signal to operate the 5/2 double pilot valve. This will cause the cylinder to move to the 'plus' position. A cam on the piston rod will operate the roller plunger valve and this will give a signal to re-set the 5/2 valve. The piston rod will then automatically move to the 'minus' position and wait until a further operation of the push button is given.





**Fig. 34.31** Circuitry building block.

These provide adjustable speed control for each movement. To RUN and END the repeating cycle a 3/2 manually operated valve is included.

The two building blocks form a complete circuit by having their command and feedback lines connected together. The method of interconnection is achieved by application of this simple rule:

‘The proof of position signal resulting from the completion of each movement is connected to initiate the next movement.’

The circuit can be traced as follows:

Start with the output given from the RUN/END valve when it is switched to RUN.

The a+ command is given.

Cylinder A moves +.

The a1 proof of position signal results.

This becomes the b+ command.

Cylinder B moves +.

The b1 proof of position signal results.

This becomes the a– command.

Cylinder A moves –.

The a0 proof of position signal results.

This becomes the b– command.

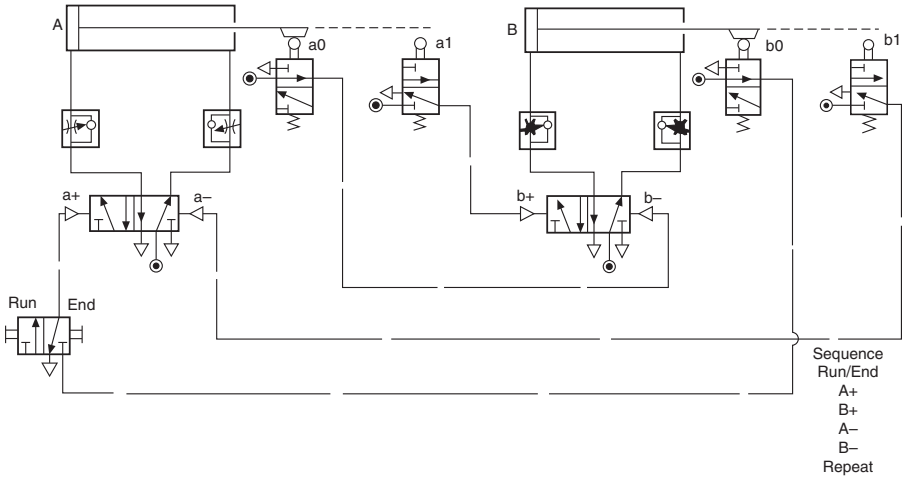
Cylinder B moves –.

The b0 proof of position signal results.

This becomes the supply to the RUN/END valve.

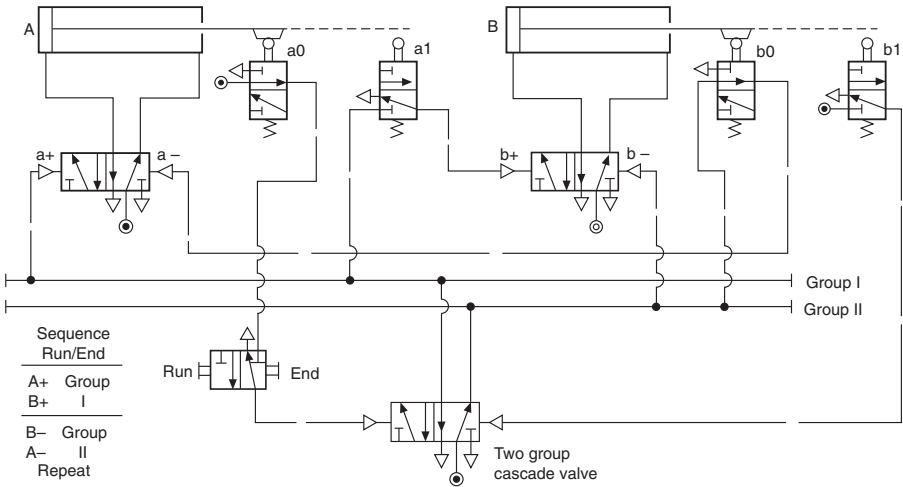
If the RUN/END valve is still switched to RUN a repeat cycle will be started.

This simple daisy chain method of interconnection will work for any number of cylinders, provided the sequence allows their return movements to occur in the same order as their first movements. For this to be true, the first movement of a cylinder need not be plus nor is it necessary for the first half of the sequence to be in alphabetical order, e.g. the sequence B + A – D + C – B – A + D – C + conforms to these rules and can be solved with this simple daisy chain method.



**Fig. 34.32** Two circuitry building blocks.

If the cylinders do not return in exactly the same order as their first movements complications will arise. Take for example, the sequence  $A + B + B - A -$  and repeat. If we try to interconnect the equipment for this sequence in the same way as before, there will be two states where the 5/2 valves will have both a 'plus' and 'minus' command existing at the same time, therefore preventing operation. This condition is commonly known as *opposed signals* and can be cured in a variety of ways. For the most reliable and economical method we suggest the use of the Cascade system (see Fig. 34.33).



**Fig. 34.33** Cascade system.

The cascade technique is to switch on and off the supply air to the critical trip valves in groups. The need for this will occur when a trip valve's mechanism is still held down, but the output signal has been used and requires removing. By switching off

the group air that is supplying the valve, the output is also removed and achieves the desired result. After the valve's mechanism is naturally released in the sequence, the group supply is switched on again in time for its next operation. To determine the number of cascade groups for any sequence, the sequence must be split into groups starting at the beginning, so that no letter is contained more than once in any group. The group numbers are given roman numerals to avoid confusion with other numbering systems that may exist on larger systems. The placing of the RUN/END valve should be in the line that selects group I. This determines that the first task of group I is to signal the first movement of the sequence. In addition, when the circuit is at rest, inadvertent operation of an uncovered trip valve will not risk an unwanted operation of a cylinder.

By studying Fig. 34.33, it can be seen that the sequence splits into two groups. These groups are supplied from a single, double pressure operated 5/2 valve, so that only one group can exist at any time. This is known as the *cascade valve*.

It can also be seen that neither of the 5/2 valves controlling the cylinders can have the + and - command lines as opposed signals, since their source is from different groups.

The circuit can be traced as follows:

To start, set RUN/END valve to RUN. This generates a command to select group I.

Group I gives a command a-.

Cylinder A moves +.

Valve a1 is operated and generates a command b+.

Cylinder B moves +.

Valve b1 is operated and generates a command to select group II.

Group II gives a command b- (because group I has been switched off there is no opposing signal from a1).

Cylinder B moves -.

Valve b0 is operated and generates a command a- (no opposed signal).

Cylinder A moves -.

Valve a0 is operated and generates a command to start the sequence again.

If at any time the RUN/END valve is switched to END, the current cycle will be completed, but the final signal will be blocked and no further operation will occur.

The rules for interconnection are as follows:

1. The first function in each group is signaled directly by that group supply.
2. The last trip valve to become operated in each group will be supplied with main air and cause the next group to be selected.
3. The remaining trip valves that become operated in each group are supplied with air from their respective groups and will initiate the next function.

## Pneumatics and electronics

Systems of low complexity and those in use in hazardous areas, not compatible with electronics, will probably be designed as pure pneumatic systems.

A purely pneumatic system can be viewed as three main sections:

1. Generation and preparation of the compressed air source.
2. Power actuation of pneumatic cylinders through directional control valves.
3. Pneumatic signal processing or logic control.

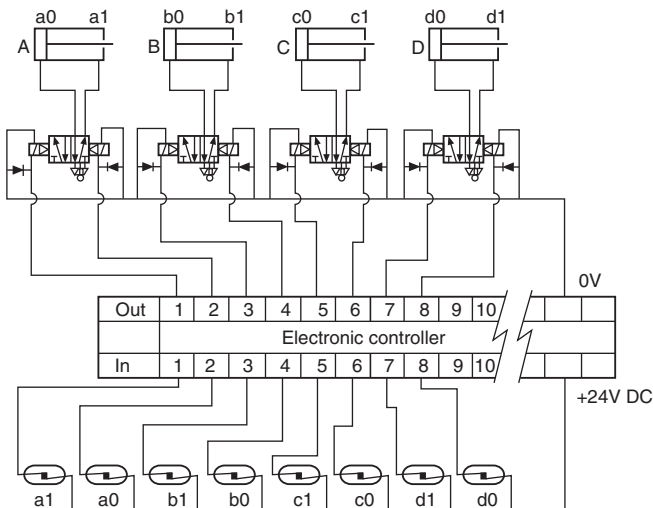
Electronics can influence all of these sections, for example:

- a. By electronic management control of compressors and controlled pressure regulation.
- b. In [Section 2](#) there are solenoid valves that provide proportional flow and pressure, together with air cylinders having electronic proportional feedback.
- c. In [Section 3](#), for many systems pneumatic logic has been replaced completely by electronic sequence or logic control.

Programmable sequence controllers (sequencers) and programmable logic controllers (PLCs) are commonly used devices and offer a wide range of features such as timing, counting, looping and logic functions. If a proposed scheme involves a sequence of events more complicated than that shown in [Fig. 34.33](#), then electronic possibilities should be explored. In addition to sequence operations there may be the additional complications from long-counting operations, or a number of time delays, requiring a high degree of repeatable accuracy. Here the electronic controller will usually be the better choice. Inputs to the controller indicate the completion of the cylinder movement.

These are most conveniently achieved by using a magnetic cylinder fitted with reed switches. The reed switch consists of two spring-like metal reeds within a sealed enclosure. When a magnet around the piston is within range, the reeds are magnetized, each having a N and S pole. As the free ends will be of the opposite polarity they snap together. For environments where strong magnetic fields exist mechanical limit switches may be used.

The scope of such a system will be appreciated from [Fig. 34.34](#). Programming methods vary with the type of controller and for someone with no experience it is



**Fig. 34.34** Programmable sequence controllers.

generally easier than they think. Sequencers are designed to be easy to program and are a good choice for machines where the actions are performed in a one-after-the-other interlock. Sequencers are able to jump from one part of the sequence to another, run sections of a sequence in a repeating loop, time, count and perform logic functions such as AND, OR, NOT. It may also be possible to hold several sequences in a memory and select the desired one for a particular task. Sequencers will have a built in range of control buttons to provide facilities such as run/end cycle, emergency stop, single cycle, auto cycle and manual over-ride.

It takes a little longer to program a PLC. This is produced by keying in a list of logic statements first determined by drawing a ladder diagram. A ladder diagram for a PLC is a logic circuit of the program as it relates to a machines function and sequence. The ladder diagram illustrated in Fig. 34.35 is derived from, and similar to, the ladder electrical circuits used to design electro mechanical relay systems.

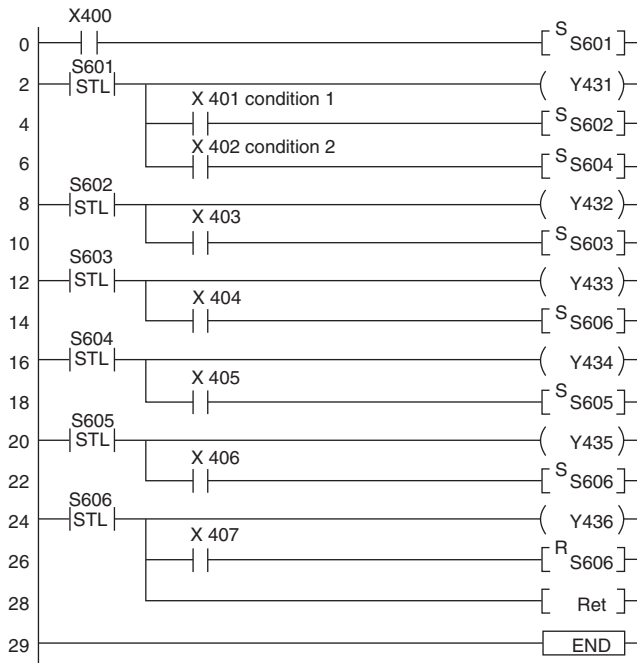



















Fig. 34.35 Ladder diagram.

Pneumatic and electronic systems play an important part in production engineering and typical applications are the control of the main axes of variable pick and place arms and robotics.

The authors wish to express their thanks for the assistance given and permission to include examples of applications of pneumatic controls manufactured by Norgren Martonair Limited – [www.norgren.com](http://www.norgren.com).

The BS 1533 series, parts 1, 2 and 3, specifies graphical symbols for use in general engineering. Within the European Community, many additional symbols are in common use and a selection of these are included here for reference purposes (Table 34.3).





















**Table 34.3** General additional symbols in common use

	<b>Equipment Labelling</b>
	positioning or flow direction
	steps
	on
	off
	stand-by (stand-by position)
	day (normal mode), sun, brightness
	cooling, frost, cold (below 0 °C)
	heating flame
	wind, wind influence (international)
	manual actuation, manual control
	safety insulation, electrical protection Class II
	extra-low voltage (up to 50 volts), protection Class III
	dangerous electrical voltage (voltage indication)
	flow arrow, indicating passage, entry and exit of important substances
	indicator arrow
	temperature increase, increase temperature
	temperature reduction, reduce temperature

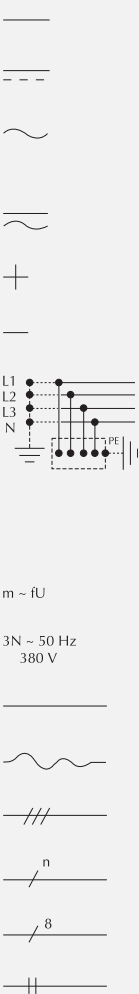
	<b>Systems symbols</b>
	heating energy, energy demand
	heat exchanger, general with substance flows crossing
	heat exchanger, general without substance flows crossing
	tank, general (pressureless)
	tank with convex bottom, general (for high pressure)
	isolating valve (general) two way valve
	three way valve
	four way valve
	flow symbols:
	– variable
	– constant
	mixing
	diverting
	shower, nozzle
	steam trap
	filter
	manual actuator
	self operated actuator (or actuator in general)
	electromotoric actuator
	electrothermic actuator

*Continued*

**Table 34.3** General additional symbols in common use—cont'd

	Systems symbols
	hydraulic or pneumatic actuator
	diaphragm actuator
	cam control
	electromagnetic actuator
	example: magnetic valve showing flow
	liquid pump, circulating pump, general
	fan (general)
	compressor (general)
	compressor, 4 step
	compressor, 4 step
	air damper
	air filter (general)
	heating coil
	cooling coil
	device or function unit, general
	modulating controller (general)
	keys, keyboard
	sensor with on-off function (thermostat, hygrostat pressure switch etc.)
	sensor with on-off function (thermostat, hygrostat pressure switch etc.) with immersion, duct or capillary pocket
	immersion thermostat for temperature

**Table 34.3** General additional symbols in common use—cont'd

	Systems symbols
<p>Other references examples:</p> <p>x absolute humidity</p> <p>P pressure</p> <p><math>\Delta p</math> differential pressure</p> <p>V flow, volume flow rate</p> <p>v velocity</p> <p>h enthalpy</p> <p>aq air quality (SCS)</p> <p>Ⓢ occupancy</p>	
	Symbols for electrical schematics
	<p>DC-current, also DC-voltage (general)</p> <p>alternative (use this symbol only where there is a risk of confusion on diagrams)</p> <p>AC-current, also frequency in general AC-voltage (frequency indicated where necessary – on the right of the symbol, e.g. ~50 Hz)</p> <p>suitability for use on either DC or AC supply</p> <p>positive polarity</p> <p>negative polarity</p> <p>definitions of electric conductors</p> <p>–L Phase (formerly PH)</p> <p>–N Neutral (formerly N)</p> <p>–L<sub>1</sub> Phase 1 (formerly R)</p> <p>–L<sub>2</sub> Phase (formerly S)</p> <p>–L<sub>3</sub> Phase (formerly T)</p> <p>–PE Earth</p> <p>AC-current with m phases, frequency f and voltage U</p> <p>Example: three-phase AC-current with neutral wire, 50 Hz, 380 V (220 V between phase wire and neutral wire)</p> <p>one wire or a group of wires</p> <p>flexible wires</p> <p>line showing the number of wires e.g. 3 wires</p> <p>numbers of wires = n</p> <p>example: 8 wires</p> <p>line showing the number of circuits e.g. 2 circuits</p> <p>Combining wires for the sake of simplicity in wiring diagrams</p>

Continued

**Table 34.3** General additional symbols in common use—cont'd























	<b>Symbols for electrical schematics</b>
	combined wires, general , any sequence on each side (wires should be coded)
	combined wires, general, as above but single line representation
	general symbol denoting a cable
	example: 2 core cable
	example: 2 core cable 'screened' (general)
	coaxial line, screened
	crossing of conductor symbols no electrical connection
	junction of conductors
	general contact, in particular one that is not readily separable; e.g. soldered joint
	readily separable contact; e.g. terminal on controller base
	terminals: device terminals
	control panel terminals:
	— on connection diagram
	— on circuit diagram
	plug or plug pin
	socket outlet
	fuse general
	fuse showing supply side
	voltage fuse general over voltage discharge device surge arrester

**Table 34.3** General additional symbols in common use—cont'd








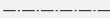
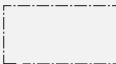








	<b>Symbols for electrical schematics</b>
	isolating point with plug-in connection
	earth, general
	safety conductor, safety earth
	chassis, general
	GND (ground, common chassis)
	resistor, general
	inductor, inductive reactance
	capacitor, capacitive reactance
	polarized (electrolytic) capacitor
	motor, general
	transformer with two separate windings
	as above (alternative representation)
	battery of cells or accumulators (the long line represents the positive pole)
	mechanical coupling: — general symbol
	— symbol used when space is limited
	linear motion: — to the right
	— to the left
	— both directions
	rotational motion: — clockwise
	— anti-clockwise
	— both directions
	thermostat, hygrostat etc.

*Continued*

**Table 34.3** General additional symbols in common use—cont'd








	<b>Symbols for electrical schematics</b>
	e.g. p → pressure switch
	Manually operated control, general
	— this symbol is used when space is limited
	manual operation by pushing
	manual operation by pulling
	manual operation by turning
	manual operation by toggle or lever
	actuator general, e.g. for relay, corrector
	electromechanical actuator, e.g. showing active winding
	electromechanical actuator with two windings active in the same direction
	signal lamp general 'operation'
	signal lamp, flashing for fault
	signal lamp 'fault', emergency lamp
	buzzer
	bell
	horn
	siren
	transducer, signal transducer, transmitter, general symbol
	rectifier, rectifying device general
	amplifier general symbol
	oscillograph, general symbol
	recording/measuring device, recorder

**Table 34.3** General additional symbols in common use—cont'd

	<b>Symbols for electrical schematics</b>
	recording/measuring device printer
	remote operation, general
	adjuster
	communication (electronic)
	clock, general
	synchronous clock
	time clock
	dividing line (e.g. between two zones or to separate a space)
	example: control panel
	(IEC) semi-conductor rectifier diode
	zener diode
	PNP—transistor E — emitter C — collector B — base
	NPN-transistor the collector is connected to the housing
	optocoupler (SCS) combined symbol
	Variability inherent linear variability under influence of a physical variable
	inherent non-linear variability under influence of a physical variable
	continuous variability by mechanical adjustment, general

*Continued*

**Table 34.3** General additional symbols in common use—cont'd

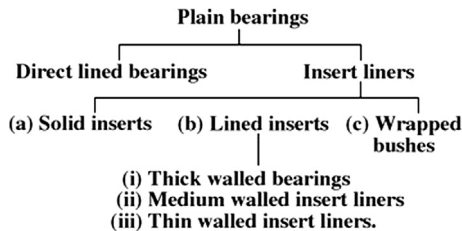
		Symbols for electrical schematics	
		adjustable in steps	
		non-inherent non-linear variability	
		continuous variability by mechanical adjustment, linear	
		continuous variability by mechanical adjustment, non-linear	
		pre-set mechanical adjustment general symbol	
	Example: temperature dependent resistor with negative temperature coefficient (thermistor)		
Wire colour abbreviations:			
bl	blue	ws	white
dbl	dark blue	sw	black
hbl	light blue	og	orange
rt	red	vl	violet
gb	yellow	gb/gn	yellow/green
gn	green	bn	brown
gr	grey		
International colour code			
Colour reference for resistance value and its tolerance			
		Tolerance class:	
		- without colour reference ± 20%	
		* - silver ± 10%	
		* - gold ± 5%	
		- red ± 2%	
		- brown ± 1%	
		* As alternative colours the following are valid on the 4th ring:	
		green instead of gold for ± 5%	
		white instead of silver for ± 10%	
black	0	0	-
brown	1	1	0
red	2	2	00
orange	3	3	000
yellow	4	4	0 000
green	5	5	00 000
blue	6	6	000 000
violet	7	7	0 000 000
grey	8	8	00 000 000
white	9	9	-
e.g brown - green - red - gold			
	1	5	00 = 1500 ± 5%

When surfaces rotate or slide, the rotational or sliding motion results in friction and heat. Energy is used, the surfaces wear, and this reduces component life and product efficiency. Friction may be reduced by lubrication which keeps the surfaces apart. At the same time, lubricants dissipate heat and maintain clean contact surfaces. Materials are carefully selected with appropriate mechanical and physical properties for bearings and their housings, to minimize the effects of friction, and particular care is taken with the accuracy of machining, surface finish and maintenance of all component parts associated with bearings.

In a plain bearing, the relative motion is by sliding in contrast with the rolling motion of ball and roller bearings.

## Plain bearings

Plain bearings may be classified as follows:



The bearing metal should have a low coefficient of sliding friction, be able to conduct heat generated away from the bearing surfaces, resist wear in use and be tough enough to withstand shock loading in service. In the event of breakdown due to lack of lubrication, it may be desirable when overheating occurs for the bearing material to run, preventing seizure and possible severe damage to associated mechanical parts.

### *Direct-lined housings*

These housings are lined directly with bearing materials and the choice of material is limited by the practicality of keying or bonding the bearing material to the housing surface.

The dimensions of the housings, casting temperatures and bonding characteristics of the bearing materials will determine whether metallurgical bonding is possible without unacceptable distortion of the housing. Generally this technique is limited to ferrous housings with low-melting point whitemetal bearing surfaces. Light alloy and zinc base housings are difficult to line directly with whitemetal.

### ***Insert liners***

These are bearing elements which consist of a liner inserted into a previously machined housing and they can be divided into separate classes:

- (a) Solid-insert liners
- (b) Lined inserts
- (c) Wrapped bushes.

*Solid-insert liners:* Manufactured wholly from suitable bearing materials such as aluminum alloy, copper alloy or whitemetal, these liners consist of machined bushes, half bearings and thrust washers.

The housings are machined to relatively close tolerances. An insert may be finished machined after assembly or a prefinished standard precision liner added as a final operation and this has the added advantage of spares replacement.

Typical applications of insert liners are to be found in diesel engine small bores, crank shaft main bearings, bushes for gearboxes, steering gear and vehicle suspensions.

*Lined inserts:* These consist of a backing material such as cast iron, steel or a copper alloy which has been lined with a suitable bearing surface of aluminum or copper alloy, or of whitemetal. This type can also be supplied as a solid insert, a split bush, half bearing or thrust washer.

Insert bearing half liners are manufactured as:

- (a) Rigid or thick-walled bearings
- (b) Medium-walled bearings
- (c) Thin-walled bearings.

*Thick-walled bearings:* These are backing shells of cast iron, steel pressings and copper base alloys generally lined with whitemetal and copper alloys and are used to produce bearings which are manufactured as pairs and used in turbines, large diesel engines and heavy plant machinery. Usually more economic than direct lined housings, these bearings may be provided with a finishing allowance for the bore and length which is adjusted during assembly.

*Medium-walled insert liners:* Normally a steel backing is used with a wide range of lining materials. Bearings are prefinished in bore and length and manufactured as interchangeable halves.

*Thin-walled insert liners:* These are high precision components with steel backing and whitemetal or copper and aluminum base alloy surfaces, and are suitable for

universal application in large production products such as high-speed diesel engines and compressors.

*Wrapped bushes:* These are pressed from flat strip of rolled bronze, or steel lined with whitemetal, lead bronze, copper lead, or aluminum alloys. They are supplied as a standard range of prefinished bushes or with a bore allowance for finishing in situ by fine boring, reaming, broaching or burnishing. These are suitable for all bushing applications in which the tolerable wear will not exceed the thickness of the lining material.

### ***Plain bearing lubrication***

The requirements of a lubricant can be summarized as follows:

- (1) To support the bearing when static and under all speed and load conditions.
- (2) To have a low coefficient of friction.
- (3) To be non-corrosive to the materials used in the bearings.
- (4) To maintain viscosity over the operating range of temperature.
- (5) Able to provide an effective bearing seal.
- (6) Have the ability to adhere as a film to the bearing.
- (7) Be able to conduct heat rapidly.

No single lubricant can satisfy all of these properties and the design of the equipment will determine which aspect needs priority before a choice from available types can be made.

### ***Plain bearing materials***

The application of the bearing, the bearing material and the lubricant used are all interdependent, but four basic requirements are necessary for the material:

- (1) Strong enough to resist failure by fatigue or overheating.
- (2) Good wear resistance and running properties.
- (3) Good lubricant retention.
- (4) High corrosion resistance which may arise due to temperature, the environment and lubricants used.

A wide range of materials consists of metallic, metallic backings with various bearing surfaces, reinforced synthetic resin, graphitic and sintered metallic. Various surface treatments are also available to improve wear resistance and reduce friction.

### ***Whitemetals***

These are a large range of either lead base or tin base alloys and are covered by British Standards. Antimony is used as a hardening agent since tin and lead are soft. Whitemetal is a low-melting point alloy which is compatible with virtually any type of

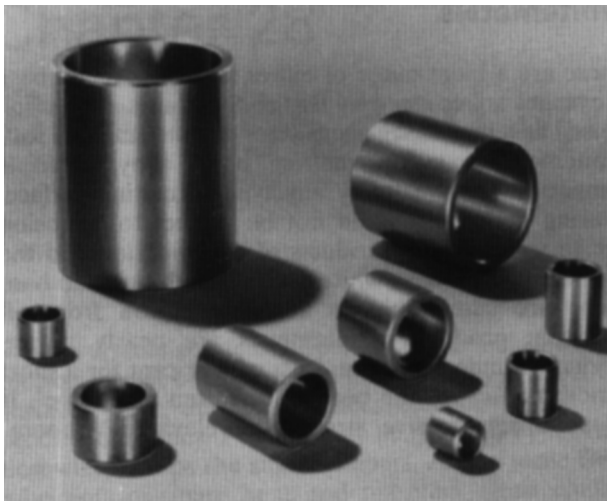
mating surface. Bearing materials should not be subject to corrosion due to water or the products of oil oxidation and the resistance of tin base whitemetals is high but lead base alloys are susceptible to acidic corrosion from oil oxidation products. Whitemetals are nearly always lubricated under pressure. Loss of lubricant for a short period may cause the bearing to soften and 'wipe'. It loses its compressive strength at elevated temperatures.

### ***Other bearing materials***

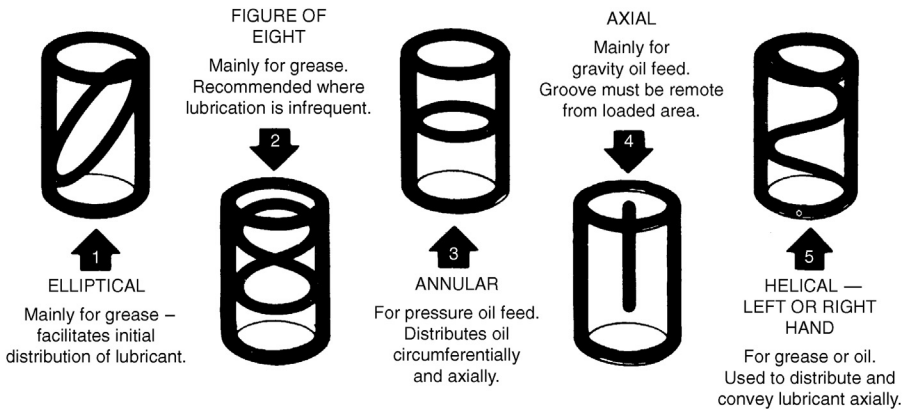
Other materials for plain bearings include copper lead alloys, lead bronzes, tin bronzes (phosphor bronze), gunmetals and aluminum base alloys.

Before concluding this section it should be stated that metallic porous metal bearings are widely used which are manufactured by powder metallurgy where very fine metal powders are mixed and compressed in molds to the correct form and sintered at high temperature in a reducing atmosphere. The product is in effect a metal sponge which can be impregnated with lubricating oil. The porosity depends on the initial compression and these products are designed for suitable applications where high volume is required. Self-lubricating materials are also available in tube and bar form for individual manufacture.

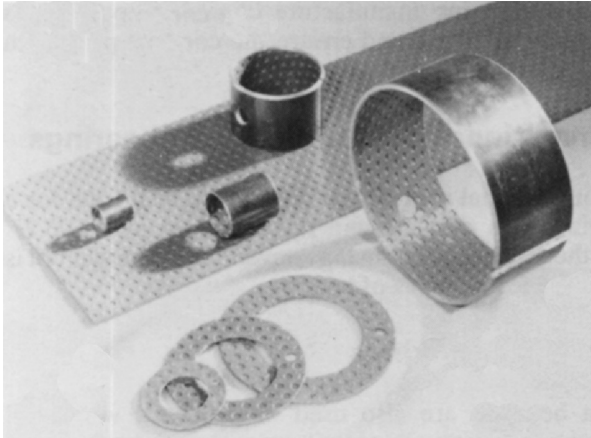
Figs. 35.1–35.9 show a selection of different types of bearing from the range manufactured by The Glacier Metal Company Limited. It is generally the case that for small quantities a design, for economic reasons, should incorporate a standard bearing as first choice if possible. Bearing manufacturers employ applications engineers to advise on and ensure the correct application and use of their products.



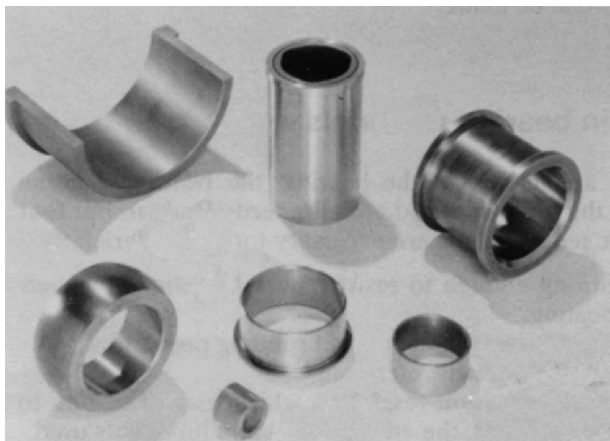
**Fig. 35.1** Selection of standard stock bushes manufactured in lead bronze.



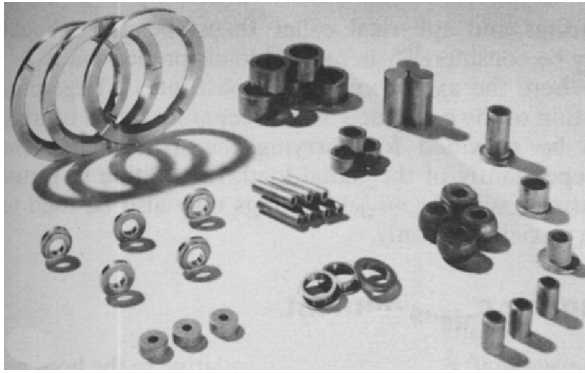
**Fig. 35.2** Types of groove which can be added for lubrication.



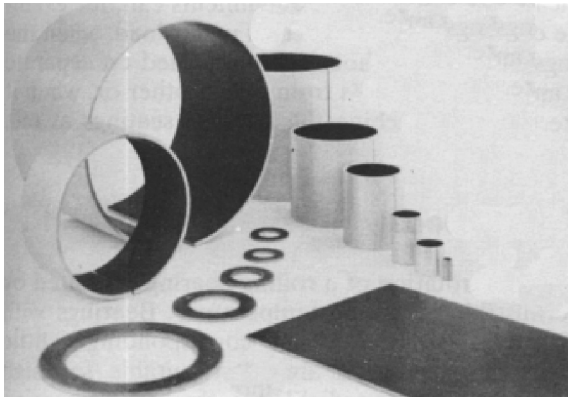
**Fig. 35.3** Prelubricated bearings have an acetal co-polymer lining. The indentations in the linings provide a series of grease reservoirs.



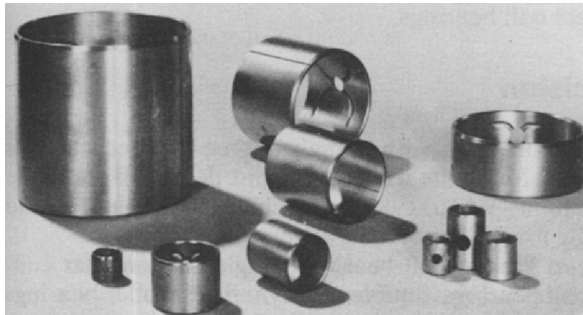
**Fig. 35.4** Fully machined components from self-lubricating materials produced by powder metallurgy.



**Fig. 35.5** Components pressed to finished size by powder metallurgy techniques.



**Fig. 35.6** Dry bearings requiring no lubrication with a PTFE/lead bearing surface.



**Fig. 35.7** Standard wrapped bushes, steel backed lined with lead bronze.



**Fig. 35.8** Thick walled bearings are produced as bushes, half bearings and thrust washers in copper and aluminum base alloys, also tin and lead base whitemetals.



**Fig. 35.9** Structural plain bearings.

## ***Structural bearings***

Plain bearings are also used in structural work and bridge construction to permit expansion and movement, and a selection are shown below with an indication of possible motions. This type of bearing utilizes the low-friction properties of polytetrafluoroethylene (PTFE) and in the applications shown can withstand a maximum live loading up to  $45 \text{ N/mm}^2$ . Illustrations of bearings in Figs. 35.1–35.9 are reproduced by kind permission of the manufacturers, GGB Bearing Technologies — [www.ggbearings.com](http://www.ggbearings.com).

## **Ball and roller bearings**

### ***Bearing selection***

Each type of bearing has characteristic features which make it particularly suitable for certain applications. However, it is not possible to lay down hard and fast rules for the selection of bearing types since several factors must be considered and assessed relative to each other. The following recommendations will, for a given application, serve to indicate those details of greatest importance in deciding the type of bearing to be used.

### ***Available space***

In many instances at least one of the main dimensions of the bearing, usually the bore, is predetermined by the machine design. Deep-groove ball bearings are normally selected for small diameter shafts whereas cylindrical-roller bearings, spherical-roller bearings and deep-groove ball bearings can be considered for shafts of large diameter.

If radial space is limited then bearings with small sectional height must be selected, e.g. needle roller assemblies, certain series of deep groove-bearings and spherical-roller bearings.

Where axial space is limited and particularly narrow bearings are required then some series of deep-groove ball bearings and cylindrical-roller bearings can be used.

### ***Bearing loads***

*Magnitude of load* — This is normally the most important factor in determining the size of bearing. Generally, roller bearings can carry greater loads than ball bearings of the same external dimensions. Ball bearings are mostly used to carry light and medium loads, whilst roller bearings are often the only choice for heavy loads and large diameter shafts.

*Direction of load* — Cylindrical-roller bearings having one ring without flanges and needle-roller bearings can only carry radial loads. Other types of radial bearing can carry both radial and axial loads.

Thrust-ball bearings are only suitable for axial loads. Spherical-roller thrust bearings, in addition to very heavy axial loads, can also carry a certain amount of simultaneously acting radial load.

A combined load comprises a radial and an axial load acting simultaneously.

The most important feature affecting the ability of a bearing to carry an axial load is its angle of contact. The greater this angle the more suitable is the bearing for axial loading. (Refer to maker's catalog for individual values.) Double and single row angular contact ball bearings are mainly used for combined loads.

Self-aligning ball bearings and cylindrical roller bearings can also be used to a limited extent. Duplex bearings and spherical roller thrust bearings should only be considered where axial loads predominate.

Where the axial component constitutes a large proportion of the combined load, a separate thrust bearing can be provided for carrying the axial component independently of the radial load. In addition to thrust bearings, suitable radial bearings may also be used to carry axial loads only.

### ***Angular misalignment***

Where a shaft can be misaligned relative to the housing, bearings capable of accommodating such misalignment are required, namely self-aligning ball bearings, spherical roller bearings, spherical roller thrust bearings or spherical plain bearings. Misalignments can, for example, be caused by shaft deflection under load, when the bearings are fitted in housings positioned on separate bases and large distances from one another or, when it is impossible to machine the housing seatings at one setting.

### ***Limiting speeds***

The speed of rotation of a rolling bearing is limited by the permissible operating temperature. Bearings with low frictional resistance and correspondingly little internal heat generation are most suitable for high-rotational speeds. For radial loads, the highest bearing speeds are obtainable with deep groove ball bearings or cylindrical roller bearings and for combined loads the highest bearing speeds are obtainable with angular contact ball bearings.

### ***Precision***

Rolling bearings with a high degree of precision are required for shafts where stringent demands are made on running accuracy, e.g. machine tool spindles and usually for shafts rotating at very high speeds.

Deep groove ball bearings, single row angular contact ball bearings, double row cylindrical roller bearings and angular contact thrust ball bearings are manufactured to high degrees of precision both as regards running accuracy and dimensions. When using high precision rolling bearings, shaft and housings must be machined with corresponding accuracy and be of rigid construction.

## ***Rigidity***

Elastic deformation in a loaded rolling bearing is very small and in most instances can be ignored. However, the bearing rigidity is of importance in some cases, e.g. for machine tool spindles.

Due to the greater area of contact between the rolling elements and raceways, roller bearings, e.g. cylindrical roller bearings or taper roller bearings, deflect less under load than ball bearings. The rigidity of the bearings can be increased by suitable preloading.

## ***Axial displacement***

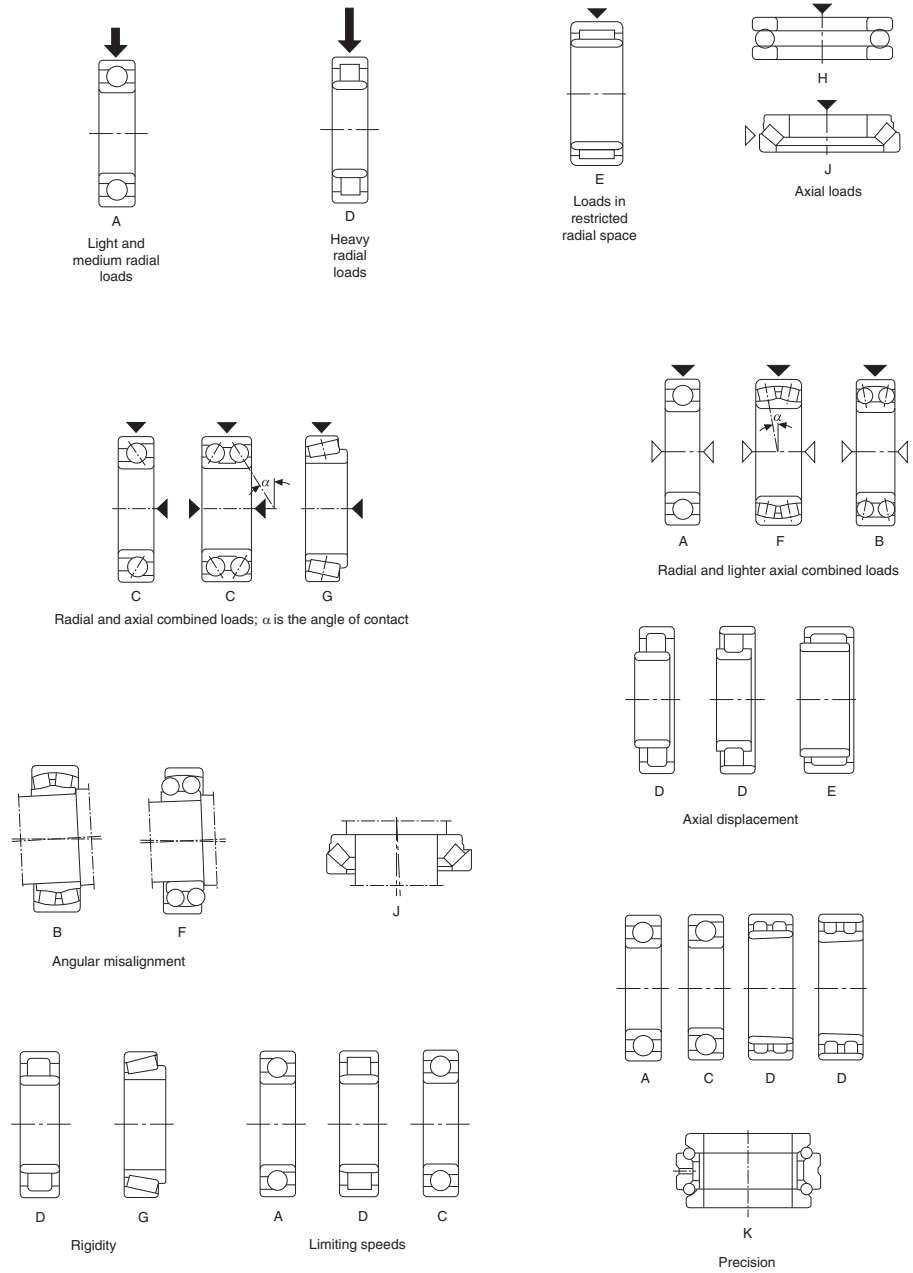
The normal bearing arrangement consists of a locating (fixed) bearing and a non-locating (free) bearing. The non-locating bearing can be displaced axially thus preventing cross location, e.g. by shaft expansion or contraction. Cylindrical roller bearings having one ring without flanges or needle roller bearings are particularly suitable for use as free bearings. Their internal design permits axial displacement of the inner and outer rings in both directions. The inner and outer rings can therefore be mounted with interference fits.

## ***Mounting and dismounting***

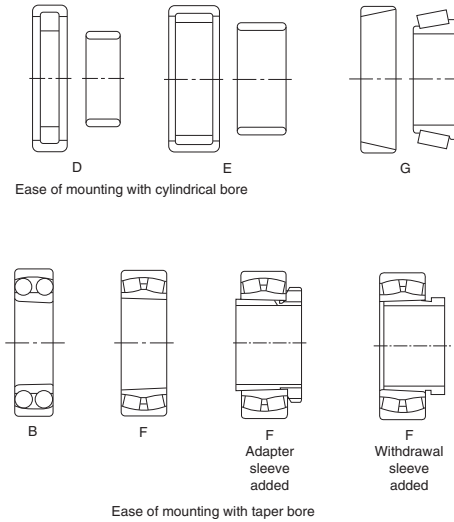
The rings of separable bearings (cylindrical roller bearings, needle roller bearings, taper roller bearings) are fitted separately. Thus, when an interference fit is required for both inner and outer rings or where there is a requirement for frequent mounting and dismounting, they are easier to install than non-separable bearings (deep groove ball bearings, angular contact ball bearings, self aligning ball bearings and spherical roller bearings).

It is easy to mount or dismount bearings with taper bores on tapered seatings or when using adapter withdrawal sleeves on cylindrical shaft seatings. Fig. 35.10 gives a simplified guide showing the suitability of the more popular types of bearing for particular applications. The type of bearing indicated for each of the features should be considered as a first choice, but not necessarily the only choice. The bearings listed are described below.

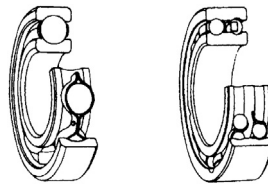
- A – Deep groove ball bearing.
- B – Self-aligning ball bearing.
- C – Angular contact ball bearing.
- D – Cylindrical roller bearing.
- E – Needle roller bearing.
- F – Spherical roller bearing.
- G – Taper roller bearing.
- H – Thrust ball bearing.
- J – Spherical roller thrust bearing.
- K – Double row angular contact thrust bearing.



**Fig. 35.10** Bearing suitability for particular applications.



**Fig. 35.10** Cont'd.



**Fig. 35.11** Single and double row deep groove ball bearings.

### **Deep groove ball bearings (Fig. 35.11)**

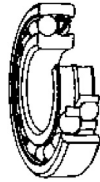
Deep groove ball bearings are available in both single row and double row designs. Single row ball bearings are the most popular of all rolling bearings. They are of simple design, non-separable and suitable for high-speed operation, and require little attention in service. The deep grooves enable axial loads to be carried in either direction. Bearings are available with shields and seals and can be supplied with the correct quantity of lithium base grease and used in operating temperatures between  $-30^{\circ}\text{C}$  and  $+110^{\circ}\text{C}$ . Special bearings operate over a wider range. Relubrication in service is not required. Shielded and sealed bearings are primarily intended for applications where the inner ring rotates. In cases where the outer ring rotates, there is a risk that lubricant will be lost and the manufacturer should be consulted.

Snap rings, fitted to bearings with snap ring grooves, provide a simple means of location.

Deep groove ball bearings have very limited ability to accommodate errors of alignment.

### **Self-aligning ball bearings (Fig. 35.12)**

Self-aligning ball bearings have two rows of balls and a common sphered raceway in the outer ring and this feature gives the bearing its self-aligning property which permits a minor angular displacement of the shaft relative to the housing. These bearings are particularly suitable for applications where misalignment can arise from errors in mounting or shaft deflection. A variety of designs are available with cylindrical and taper bores, with seals and adapter sleeves and extended inner rings.

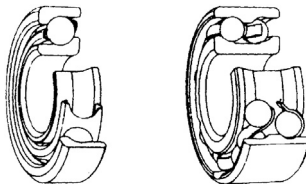


**Fig. 35.12** Self-aligning ball bearings with cylindrical bore.

### **Angular contact ball bearings (Fig. 35.13)**

In angular contact ball bearings the line of action of the load, at the contacts between balls and raceways, forms an angle with the bearings axis. The inner and outer rings are offset to each other and the bearings are particularly suitable for carrying combined radial and axial loads. The single row bearing is of non-separable design, suitable for high speeds and carries an axial load in one direction only. A bearing is usually arranged so that it can be adjusted against a second bearing.

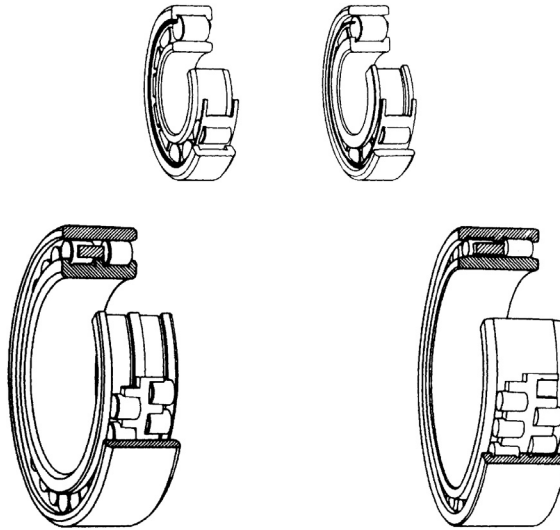
A double row angular contact bearing has similar characteristics to two single bearings arranged back to back. Its width is less than two single bearings and it can carry an axial load in either direction. These bearings are used for very accurate applications such as the shafts in process pumps.



**Fig. 35.13** Single and double row angular contact ball bearings.

### **Cylindrical roller bearings (Fig. 35.14)**

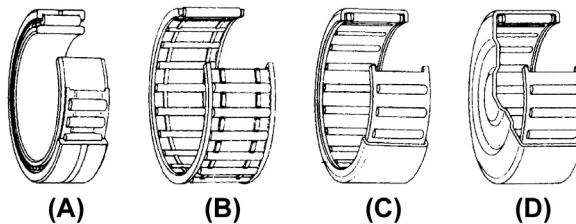
In cylindrical roller bearings, the rollers are guided between integral flanges on one of the bearing rings. The flanged ring and rollers are held together by the cage to form an assembly which can be removed from the other ring. This separable feature of the bearing design facilitates mounting and dismounting, particularly where, because of loading conditions, interference fits for both rings are necessary. Single and double row bearings are available for heavy loads, high speeds and rigidity. Typical applications are for machine tools and heavy electric motors.



**Fig. 35.14** Single and double row cylindrical roller bearings.

### **Needle roller bearings (Fig. 35.15)**

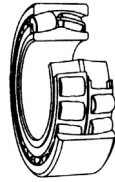
The chief characteristic of needle roller bearings is that they incorporate cylindrical rollers with a small diameter/length ratio. Because of their low-sectional height these bearings are particularly suitable for applications where radial space is limited. Needle roller bearings have a high load carrying capacity in relation to their sectional height.



**Fig. 35.15** Needle roller bearings. (A) With inner ring, (B) needle roller cage assembly, (C) drawn cup needle roller bearings with open ends and (D) drawn cup needle roller bearings with closed end.

### **Spherical roller bearings (Fig. 35.16)**

Spherical roller bearings have two rows of rollers which run on a common sphered raceway in the outer ring, the inner ring raceways each being inclined at an angle to the bearing axis. The bearings are self-aligning and permit minor angular displacements of the shaft relative to the housing which may occur in mounting or because of shaft deflection under load. Heavy duty types are available for severe operating conditions encountered in vibrating machinery such as soil compactors.



**Fig. 35.16** Spherical roller bearing.

### ***Taper roller bearings (Fig. 35.17)***

In a taper roller bearing the line of action of the resultant load through the rollers forms an angle with the bearing axis. Taper roller bearings are therefore particularly suitable for carrying combined radial and axial loads. The bearings are of separable design, i.e. the outer ring (cup) and the inner ring with cage and roller assembly (cone) may be mounted separately.

Single row taper roller bearings can carry axial loads in one direction only. A radial load imposed on the bearing gives rise to an induced axial load which must be counteracted and the bearing is therefore generally adjusted against a second bearing.

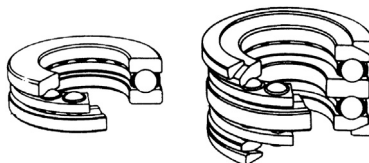
Two and four row taper roller bearings are also made for applications such as rolling mills.



**Fig. 35.17** Taper roller bearing.

### ***Thrust ball bearings (Fig. 35.18)***

Thrust ball bearings are designed to accommodate axial loads. They are not suitable for radial loads. To prevent sliding at the ball to raceway contacts, caused by centrifugal forces and gyratory moments, thrust ball bearings must be subjected to a certain minimum axial load. The bearings are of separable design and the housing and shaft washers may be mounted independently.



**Fig. 35.18** Single row thrust ball bearing.

### **Spherical roller thrust bearings (Fig. 35.19)**

In spherical roller thrust bearings the line of action of the load at the contacts between the raceways and the rollers forms an angle with the bearing axis, and this makes them suitable for carrying a radial load. This radial load must not exceed 55% of the simultaneous acting axial load. The sphered raceway of the housing washer provides a self-aligning feature which permits, within certain limits, angular displacement of the shaft relative to the housing.



**Fig. 35.19** Spherical roller thrust bearing.

### **Application of bearings**

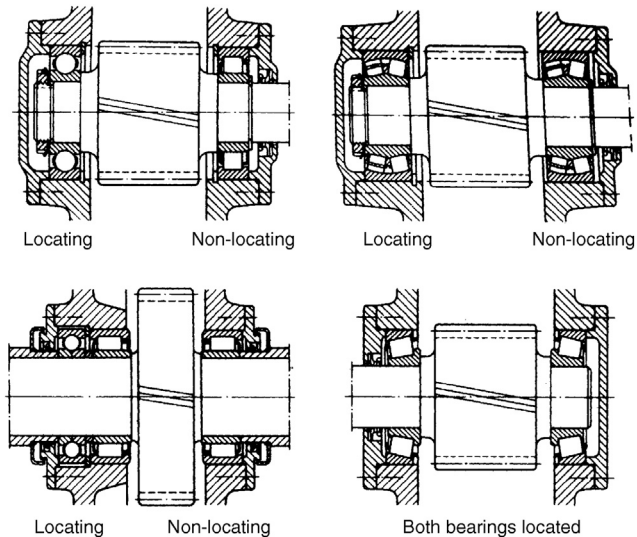
A rotating machine element, e.g. the shaft, generally requires two bearings to support and locate it radially and axially relative to the stationary part of the machine, e.g. the housing. Normally, only one of the bearings (the locating bearing) is used to fix the position of the shaft axially, whilst the other bearing (the non-locating bearing) is free to move axially.

Axial location of the shaft is necessary in both directions and the locating bearing must be axially secured on the shaft and in the housing to limit lateral movement. In addition to locating the shaft axially the locating bearing is also generally required to provide radial support, and bearings which are able to carry combined loads are then necessary, e.g. deep groove ball bearings, spherical roller bearings and double row or paired single row angular contact ball bearings. A combined bearing arrangement, with radial and axial location provided by separate bearings, can also be used, e.g. a cylindrical roller bearing mounted alongside a four-point contact ball bearing or a thrust bearing having radial freedom in the housing.

To avoid cross location of the bearings the non-locating bearing, which provides only radial support, must be capable of accommodating the axial displacements which arise from the differential thermal expansion of the shaft and housings. The axial displacements must be compensated for either within the bearing itself, or between the bearing and its seating on the shaft, or in the housing.

Typical examples of locating and non-locating bearings are shown on the applications in Fig. 35.20.

To prevent roll or creep it is important to maintain the correct fits between the bearings and seatings. Inadequate fits can result in damage to both the bearings and associated components. Normally, the only way to prevent movement at the bearing seatings is to provide a sufficient degree of interference for the bearing rings. Interference fits provide a further advantage in that relatively thin section bearing rings are properly supported around their circumference to give a correct load distribution and allow the load carrying ability of the bearing to be fully utilized. However, where



**Fig. 35.20** Locating and non-locating applications.

there is a requirement for easy mounting and dismounting of the bearing, or where a non-locating bearing must have freedom of movement axially on its seating, interference fits may not be possible.

### ***Bearings with cylindrical bore***

The most important factors to be considered when selecting bearing fits are as follows:

*Conditions of rotation* – The conditions of rotation refer to the direction of the load in relation to the bearing rings.

If the bearing ring rotates and the load is stationary, or if the ring is stationary and the load rotates so that all points on the raceway are loaded in the course of one revolution, the load on the ring is defined as a rotating load. Heavy oscillating loads such as apply to the outer rings of connecting rod bearings are generally considered as rotating loads.

If the bearing ring is stationary and the load is also stationary, or if the ring and load rotate at the same speed so that the load is always directed toward the same point on the raceway, the load on the ring is defined as a 'stationary load'.

Variable external loading, shock loading, vibrations and out of balance forces in high speed machines, giving rise to changes in the direction of the load which cannot be accurately established, are classified under the term 'direction of load indeterminate'.

A bearing ring subjected to a rotating load will creep on its seating if mounted with a clearance fit, and wear of the contacting surfaces will occur (fretting corrosion). To prevent this, an interference fit should be used. The degree of interference required is

dictated by the operating conditions referred to below in the notes on internal clearance and temperature conditions.

A bearing ring subjected to a stationary load will not normally creep on its seating and an interference fit is not therefore necessary unless dictated by other requirements of the application.

When the direction of loading is indeterminate, and particularly where heavy loading is involved, it is desirable that both rings have an interference fit. For the inner ring the fit recommended for a rotating inner ring is normally used. However, when the outer ring must be axially free in its housing or if the loading is not heavy a somewhat looser fit than that recommended for rotating loads may be used.

*Magnitude of the load* — The load on a bearing inner ring causes it to expand resulting in an easing of the fit on the seating; under the influence of a rotating load, creep may then develop. The amount of interference between the ring and its seating must therefore be related to the magnitude of the load: the heavier the load the greater the interference required.

*Internal clearance* — When bearing rings are mounted with an interference fit, the bearing radial internal clearance is reduced because of the expansion of the inner ring and/or contraction of the outer ring. A certain minimum clearance should however remain. The initial clearance and permissible reduction depend on the type and size of bearing. The reduction in clearance due to the interference fit can be such that bearings with radial internal clearance greater than normal may be necessary.

*Temperature conditions* — In service, the bearing rings normally reach a higher temperature than the component parts to which they are fitted. This can result in an easing of the fit of the inner ring on its seating or alternatively the outer ring may expand and take up its clearance in the housing thereby limiting its axial freedom. Temperature differentials and the direction of heat flow must therefore be carefully considered in selecting fits.

*Requirements regarding running accuracy* — Where bearings are required to have a high degree of running accuracy, elastic deformation and vibration must be minimized and clearance fits avoided. Bearing seatings on shafts should be at least to tolerance IT5 and housing seatings to tolerance IT6. Accuracy of form (ovality and taper) is also very important and deviations from true form should be as small as possible.

*Design and material of shaft and housing* — The fit of the bearing ring on its seating must not lead to uneven distortion (out of round) of the bearing ring, which may for example be caused by surface irregularities of the seatings. Split housings are not suitable when outer rings are to have an interference fit and the limits of tolerance selected should not give a tighter fit than that obtained when tolerance groups H or J apply. To ensure adequate support for bearing rings mounted in thin walled housings, in light alloy housings or on hollow shafts, heavier interference fits must be used than would normally be selected for thick walled steel or cast iron housings or solid shafts.

*Ease of mounting and dismantling* — Bearings having clearance fits are preferred for many applications to facilitate installation and removal. When operating conditions necessitate the use of interference fits and ease of mounting and dismantling is also essential, separate bearings or bearings having a tapered bore and an adapter or withdrawal sleeve can often provide a solution.

*Displacement of a non-locating bearing* — When a non-separable bearing is used at the non-locating position, it is necessary that under all conditions of operation one of the rings is free to move axially. This is ensured by using a clearance fit for that ring which carries a stationary load. Where for example, light alloy housings are used, it may sometimes be necessary to fit a hardened intermediate bush between the outer ring and the housing. If certain types of cylindrical roller bearings, or where needle roller bearings are used at the non-locating position, then both inner and outer rings can be mounted with an interference fit.

### ***Bearings with tapered bore***

Bearings with a tapered bore are often used to facilitate mounting and dismounting and in some cases this type of bearing may be considered essential to the application. They can be mounted either directly on to a tapered shaft, or by means of an externally tapered sleeve on to a cylindrical shaft.

The axial displacement of a bearing on its tapered seating determines the fit of the inner ring and special instructions relating to the reduction of clearance of bearings with a tapered bore must be observed. The fit of the outer ring in the housing is the same as that for bearings having a cylindrical bore. Adapter and withdrawal sleeves allow greater shaft tolerances to be used (h9 or h10). Errors of form (ovality and taper) of the shaft seating must, however, still be closely controlled (tolerance IT5 or IT7).

### ***Fits and tolerances***

Tolerances for the bore and outside diameter of metric rolling bearings are internationally standardized. The desired fits are achieved by selecting suitable tolerances for the shaft and housing using the ISO tolerance system incorporated in data sheet BS 4500A and B.

For any particular bearing, the manufacturer's catalog should be consulted with regard to recommended fits because these must be related to the actual size of the bearings supplied.

### ***Axial location of bearings***

Interference fits in general only provide sufficient resistance to axial movement of a bearing on its seating when no axial forces are to be transmitted and the only requirement is that lateral movement of the ring should be prevented. Positive axial location or locking is necessary in all other cases. To prevent axial movement in either direction of a locating bearing it must be located at both sides. When non-separable bearings are used as non-locating bearings, only one ring — the one that has the tighter fit — is axially located; the other ring must be free to move axially in relation to the shaft or housing.

Where the bearings are arranged so that axial location of the shaft is given by each bearing in one direction only it is sufficient for the rings to be located at one side only.

### **Methods of location (Fig. 35.21)**

Bearings having interference fits are generally mounted against a shoulder on the shaft or in the housing. The inner ring is normally secured in place by means of a locknut and locking washer (a), or by an end plate attached by set screws to the shaft end (b). The outer ring is normally retained by the housing end cover (c), but a threaded ring screwed into the housing bore is sometimes used (d).

Instead of shaft or housing abutment shoulders, it is frequently convenient to use spacing sleeves or collars between the bearing rings (e), or a bearing ring and the adjacent component, e.g. a gear (f). On shafts, location can also be achieved using a split collar which seats in a groove in the shaft and is retained by either a solid outer ring which can be slid over it, or by the inner ring of the bearing itself.

Axial location of rolling bearings by means of snap rings can save space, assist rapid mounting and dismounting and simplify machining of shaft and housings. An abutment collar should be inserted between the snap ring and the bearing if heavy loads have to be carried, in order that the snap ring is not subjected to large bending moments across its section. If required, the axial clearance, which is generally present between the snap ring and the snap ring groove, can be reduced by selecting an abutment collar of suitable width or by using shims. Deep groove ball bearings with a snap ring groove in the outer ring and fitted with a snap ring sometimes provide a simplified and compact housing arrangement.

Bearings with a tapered bore mounted directly on tapered shafts are usually retained by a locknut on the shaft (g), or the locknut may be screwed on to an externally threaded split ring inserted into a groove in the shaft (h). With adapter sleeve mounting, the locknut positions the bearing relative to the sleeve (j). When bearings with an adaptor sleeve are mounted on shafts without an abutment shoulder, the axial load which can be applied depends on the resulting friction between shaft and sleeve. When bearings with a tapered bore are mounted on withdrawal sleeves the inner ring of the bearing must be mounted against an abutment (k). A suitable abutment can be provided by a collar which can frequently serve as part of a labyrinth seal. The withdrawal sleeve must be secured in position either by means of a locknut or an end plate and set screws.

### **Seals**

Bearings must be protected by suitable seals against the entry of moisture and other contaminants and to prevent the loss of lubricant. The effectiveness of the sealing can have a decisive effect on the life of a bearing.

Many factors must be considered when deciding on the best sealing arrangements for a given bearing application, e.g. the type of lubricant (oil or grease), peripheral speed at the sealing surface, misalignment of the shaft, available space, friction of the seal and resultant temperature rise and cost. Two basic designs are normally used for rolling bearings.

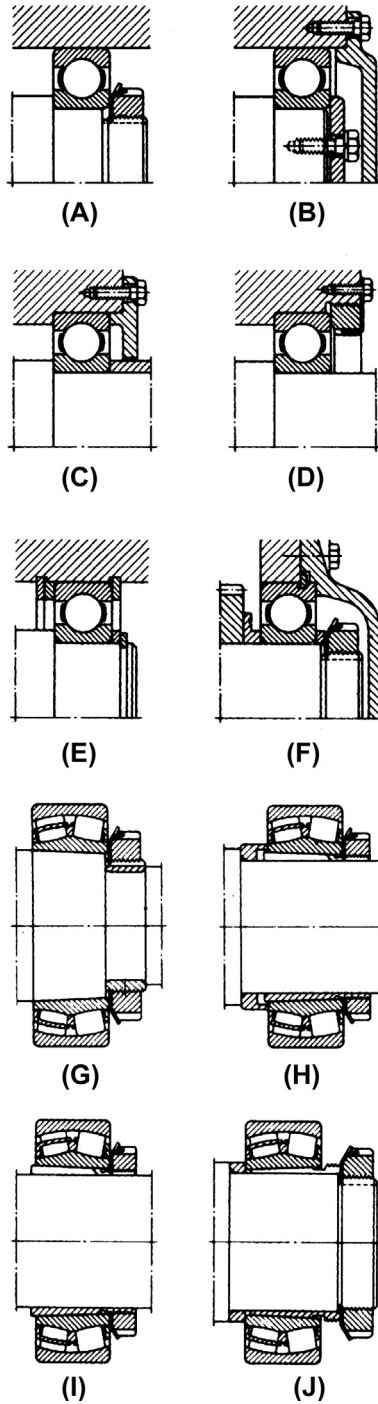


Fig. 35.21 Bearing location methods.

### Non-rubbing seals (Fig. 35.22)

Non-rubbing seals depend for their effectiveness on the sealing efficiency of narrow gaps, which may be arranged axially, radially or combined to form a labyrinth. This type of seal has negligible friction and wear and is not easily damaged. It is particularly suitable for high speeds and temperatures.

This simple gap type seal which is sufficient for machines in a dry, dust free atmosphere comprises a small radial gap formed between the shaft and housing (a). Its effectiveness can be improved by providing one or more grooves in the bore of the

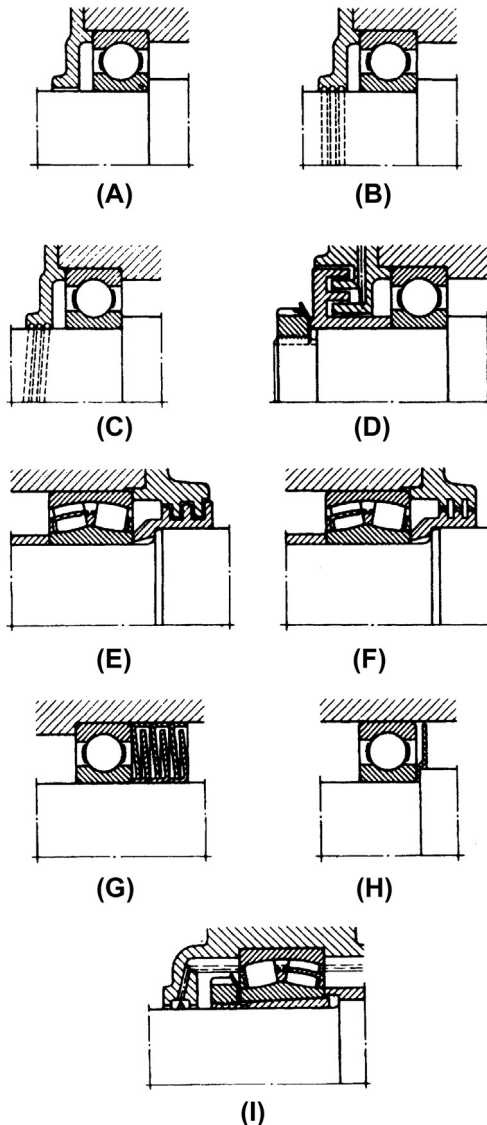


Fig. 35.22 Bearing seals - non rubbing.

housing cover (b). The grease emerging through the gap fills the grooves and helps to prevent the entry of contaminants. With oil lubrication and horizontal shafts, right or left hand helical grooves can be provided in the shaft or the seal bore (c). These serve to return any oil which may tend to leak from the housing. However, with this arrangement it is essential that the direction of rotation does not vary.

Single or multiple labyrinths give appreciably more effective sealing than gap seals but they are generally more expensive to manufacture. They are chiefly used with grease lubrication. Their effectiveness can be still further improved by providing a grease duct connecting with the labyrinth passage and periodically pumping in a quantity of water insoluble grease, e.g. a calcium soap base grease. In solid housings the tongues of the labyrinth seal are arranged axially (d), and in split housing, radially (e). The radial clearance between the shaft and the housing seal components is not affected by axial displacement of the shaft during running and can be made very small. If angular misalignment of the shaft relative to the housing has to be accommodated, labyrinths of the form shown at (f) are normally used.

An inexpensive and effective labyrinth seal can be made using pressed steel sealing washers (g). The effectiveness of this type of seal increases in direct proportion to the number of washers used. To increase the sealing efficiency of non-rubbing seals, the shaft can be fitted with rotating discs (h) and in case of oil lubrication, flinger rings (i) are often used. The oil flung from the ring is collected in a channel in the housing wall and returned to the sump through suitable ducts.

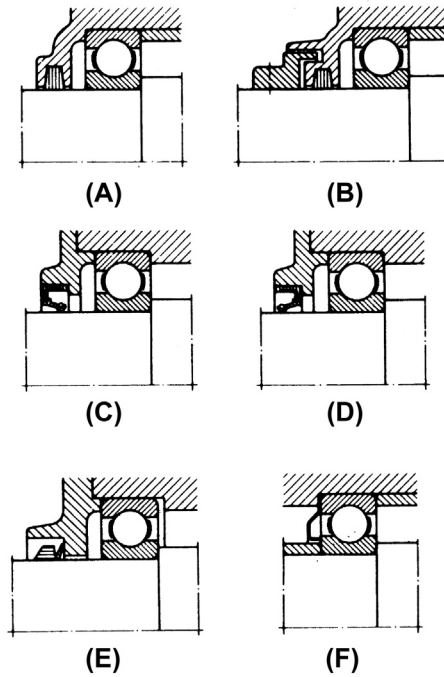
### ***Rubbing seals (Fig. 35.23)***

Rubbing seals rely for their effectiveness essentially on the elasticity of the material exerting and maintaining a certain pressure at the sealing surface. The choice of seal and the required quality of the sealing surface depend on the peripheral speed.

Felt washers (a) are mainly used with grease lubrication, e.g. in plummer blocks. They provide a simple seal suitable for peripheral speeds up to 4 m/s and temperatures of about 100 °C. The effectiveness of the seal is considerably improved if the felt washer is supplemented by a simple labyrinth ring (b). The felt washers or strips should be soaked in oil at about 80 °C before assembly.

Where greater demands are made on the effectiveness of the rubbing seal, particularly for oil lubricated bearings, lip seals are often used in preference to felt seals. A wide range of proprietary lip type seals is available in the form of ready to install units comprising a seal of synthetic rubber or plastics material normally enclosed in a sheet metal casing. They are suitable for higher peripheral speeds than felt washers. As a general guide at peripheral speeds of over 4 m/s the sealing surface should be ground, and above 8 m/s hardened or hard chrome-plated and fine ground or polished if possible. If the main requirement is to prevent leakage of lubricant from the bearing then the lip should face inwards (c). If the main purpose is to prevent the entry of dirt, then the lip should face outwards (d).

The V-ring seal (e) can be used for grease or oil lubricated bearing arrangements. It comprises a rubber ring with a hinged rubber lip which is pressed axially against the sealing surface. It is easy to fit, can accommodate fairly large angular misalignments of



**Fig. 35.23** Bearing seals - rubbing.

the shaft relative to the housing at slow speeds, and in certain circumstances is suitable for high speeds. The effectiveness of the seal owes much to the fact that dirt and liquids tend to be flung off by the rotating seal. The V-ring seal is normally fitted on the inside rotating seal. The V-ring seal is therefore normally fitted on the outside of the housing when grease lubrication is used and on the inside with oil lubrication.

Spring steel sealing washers provide a cheap and space saving seal, especially for grease lubricated deep groove ball bearings. They can be clamped either against the outer ring (f) or against the inner ring and are designed so that the sealing face is constrained to press against the face of the other bearing ring.

### ***Combined seals***

In difficult operating conditions and where severe demands are placed on sealing, e.g. large amounts of dirt or water, rubbing and non-rubbing seals are often combined. In such cases the non-rubbing seals (labyrinths, flinger rings, etc.) are arranged to supplement the rubber seals and protect them from wear.

### ***Sealed and shielded bearings***

Simple space saving arrangements can be achieved by using bearings incorporating seals or shields at one or both sides which are supplied lubricated with the correct quantity of grease. Relubrication is not normally required and they are primarily

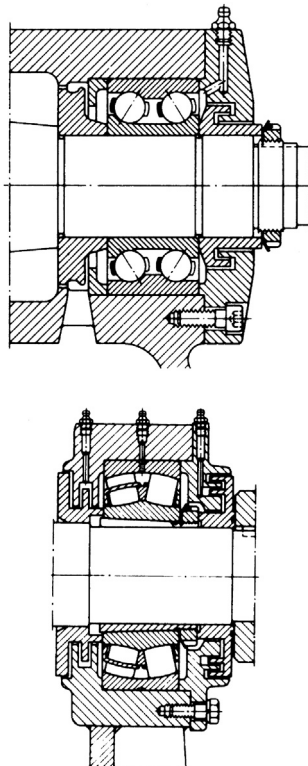
intended for applications where sealing is otherwise inadequate or where it cannot be provided for reasons of space.

### ***Grease lubrication***

Grease lubrication is generally used where ball and roller bearings operate at normal speeds, temperature and loading conditions. Grease has certain advantages by comparison with oil: it is more easily retained in the bearing housing and assists in sealing against the entry of dirt and moisture.

In general the free space in the bearing and housing should only be partly filled with grease (30–50%). Overfilling causes rapid temperature rise particularly if speeds are high. Manufacturers supply details regarding suitable weights of grease for particular bearings.

Bearings can be supplied which are sealed after prepacking with the correct type and quantity of grease. Where relubrication is more frequent, provision must be made by fitting grease nipples to the housing. Grease will then be applied by a grease gun and a lubrication duct should feed the grease adjacent to the outer ring raceway or between the rolling elements. Examples are shown in [Fig. 35.24](#).



**Fig. 35.24** Bearing seals - lubricated.

## Oil lubrication

Oil lubrication is generally used where high speeds or operating temperatures prohibit the use of grease, when it is necessary to transfer frictional heat or other applied heat away from the bearing, or when the adjacent machine parts, for example gears, are oil lubricated.

Oil bath lubrication is only suitable for slow speeds. The oil is picked up by rotating bearing elements and after circulating through the bearing drains back to the oil bath. When the bearing is stationary, the oil should be at a level slightly below the center of the lowest ball or roller. An application is shown in Fig. 35.25. At high speeds it is important that sufficient oil reaches the bearing to dissipate the heat generated by friction and oil jets provide an effective method (Fig. 35.26).

The illustrations in this section (Fig. 35.10–35.26) are reproduced by kind permission of SKF (UK) Limited – [www.skf.co.uk](http://www.skf.co.uk).

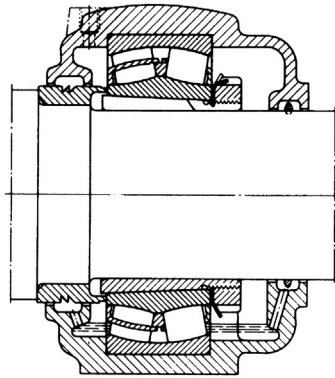


Fig. 35.25 Oil bath lubrication.

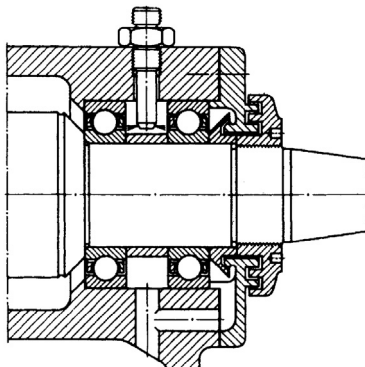


Fig. 35.26 Oil jet lubrication.

### ***Trouble-free bearing operation***

When bearings fail, they can bring equipment to an unscheduled halt. Every hour of down time due to premature bearings failure can result in costly lost production in a capital intensive industry. Substantial investment in research and development has resulted in the manufacture of bearings of the highest quality. Quality alone cannot guarantee trouble-free bearing operation since other factors may affect life span including the following:

1. *Operating environment:* Machinery must be kept in peak operating condition. Bearings should be properly aligned and protected from extreme temperatures, moisture and contaminants.
2. *Proper installation:* Knowledge of the proper installation techniques and tools is required to ensure that the bearings are not damaged.
3. *Proper maintenance:* The following of lubrication and maintenance schedules using recommended materials and time intervals is essential. A familiarity with operating procedures, basic trouble shooting, condition monitoring and vibration analysis is also desirable.

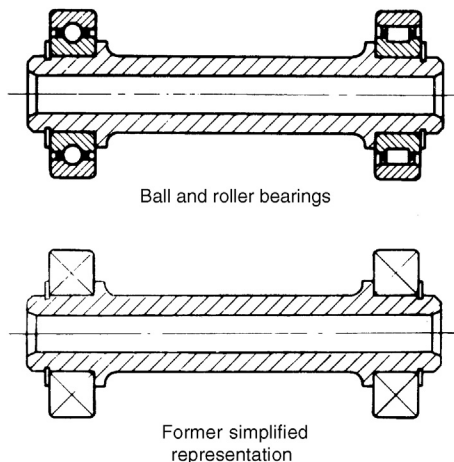
However, bearing manufacturers do have a full line of products and services to make installation and maintenance easy to perform and should be consulted. This will certainly contribute to long bearing life and ensure cost-effective operation.

### ***General convention and simplified representation***

Both types are illustrated in [Fig. 35.27](#).

Simplified representations for both types are the same. The simplification shown here with crossed diagonal lines was the practice used by industry in the past.

Current practice introduces a free-standing upright cross referred to in ISO 8826-1.



**Fig. 35.27** Simplified representation.

The use of adhesives is now a well-established practice in manufacturing. New materials and production processes have considerably increased the options available to the engineering designer. Adhesive bonding is a proved, cost-effective manufacturing method and can be used with confidence. A basic principle is that joints should be designed with this method of production in mind when the product is in the early stages of development.

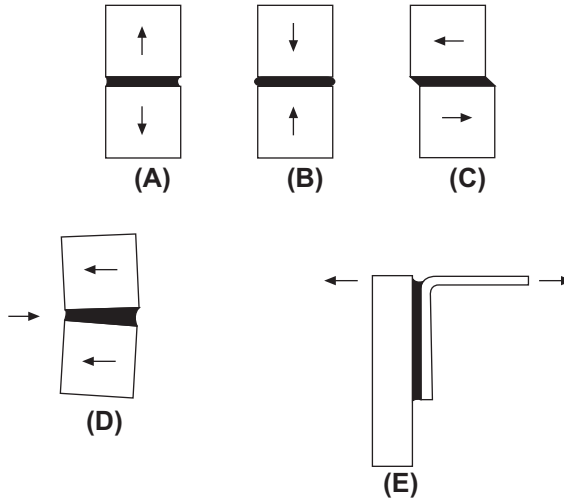
The following are some advantages of using adhesives:

- (a) Stress concentrations present in bolted, riveted or spot welded joints are avoided.
- (b) The distribution of stresses achieved by adhesive bonding permits a reduction in weight and cost, especially relevant with fragile materials and lightweight structures. Joint strength and fatigue properties are improved.
- (c) Production costs are reduced due to the elimination of drilled holes and other machining operations. Labor costs are reduced with automated assembly work.
- (d) Structures are generally stiffer despite weight reduction since the bonding covers the whole area of the joint. Rivets, screws and spotwelds pin the surfaces together only at localized points. Loading may be increased before buckling occurs.
- (e) Gap filling properties. Certain adhesives are gap filling, and this makes possible the continuous joining of materials where the gap along the joint is of irregular width.
- (f) Delicate or brittle materials such as metal foils or ceramics are readily bonded.
- (g) High-strength bonds can be formed at room temperature with minimal pressure by using cold-setting adhesives.
- (h) The film formed by the adhesive resists corrosion, and can form a leak-proof seal and insulate dissimilar metals against electrochemical action.

## Designing for adhesives

For the best possible performance, joints should be specifically designed for adhesive bonding. Follow this principle and much better joints will be achieved than if bonding is adopted as a substitute for welding in a joint designed for that purpose. Bond stresses, materials, type of adhesive, surface preparations, method of application and production requirements can then all be considered in relation to each other at the outset. The designer should consider especially the effect of shear, tension, cleavage, and peel stresses upon the joint. Bonded joints perform best under conditions of tension (pure), compression or shear loading; less well under cleavage; and relatively poorly under peel loading. The loading conditions are shown in Fig. 36.1.

Designing a joint to take pure tensile or compressive stresses is normally impracticable with sheet materials, so all joints in sheet materials should be designed so that the main loading is in shear. Joints between massive parts perform well in tension or



**Fig. 36.1** Loading conditions. (A) Tension, (B) Compression, (C) Shear, (D) Cleavage, and (E) Peel.

compression loading, provided this is uniform — a side load may set up excessive cleavage stresses in a tension-loaded bond (Fig. 36.1 (d)). Cleavage loading will concentrate stress at one side of the joint. Bond area may have to be increased to withstand this load so the joint will not prove so economical in terms of material and/or adhesives as compared to joints designed for shear and tension stresses. Peel strength is usually the weakest property of a joint. A wide joint will be necessary to withstand peel stresses, plus the use of an adhesive with high-peel strength.

For an adhesive to be used, a joint must allow the easy application of the adhesive, must allow for the adhesive to cure fully, and must be designed to give uniform stress. Even in a simple face-to-face joint it must be possible to apply adhesive to one surface and for it to remain there until the two parts are brought together and after that until curing takes place.

These requirements highlight the need for a choice of thin, thick or thixotropic adhesives. Design details which may also be significant include removal of sharp edges and substitution of a bevel or radius.

## The bond line

The gap between the parts, and therefore the thickness of the adhesive film, has an important bearing on the characteristics of the joint. In terms of simple strength, a thick bond line will generally be a weakening feature, since the mechanical strength of the unsupported resin film is likely to be less than that of the substrates.

A thick bond line can however confer advantages. The adhesive is generally more flexible than the adherents or substrates. This is particularly so in most engineering

applications where metals or other rigid materials can be bonded. Because of this, a thick bond line can offer a capacity to absorb some impact energy, thus increasing the strength of the bond under this type of loading.

Consideration of bond line thickness leads immediately to the question of environmental resistance.

Adhesive bonds will always be susceptible to environmental attack and it is essential that any such attack should not reduce the strength of the bond to an unacceptable level. The most important factor here is the correct choice of adhesive, but design of the joint can make a significant difference. Thus a thick bond line offers a ready path for access by moisture or other solvents which might be able to diffuse through the cured adhesive.

## Typical bonded joints

Fig. 36.2 shows a range of bonded joints and possible modifications which can be made to reduce or eliminate the effect of cleavage and peel stresses.

The following notes should be regarded as of a general nature:

- (a) Avoid butt joints if bond area is small.
- (b) Scarfed joint provides increased bonding area.
- (c) Simple lap joint with in-line forces.
- (d) Alternative lap joint with offset loading.
- (e) Tapered lap joint.
- (f) Bracket bonded to a fixed surface where peel is likely.
- (g) Repositioned bracket strengthens joint.
- (h) and (j) Cleavage loading eliminated by the addition of a component in shear.
- (a) (k) and (l) Simple improvement for safety.
- (b) (m) and (n) Increase in bond area reinforces corner joint.

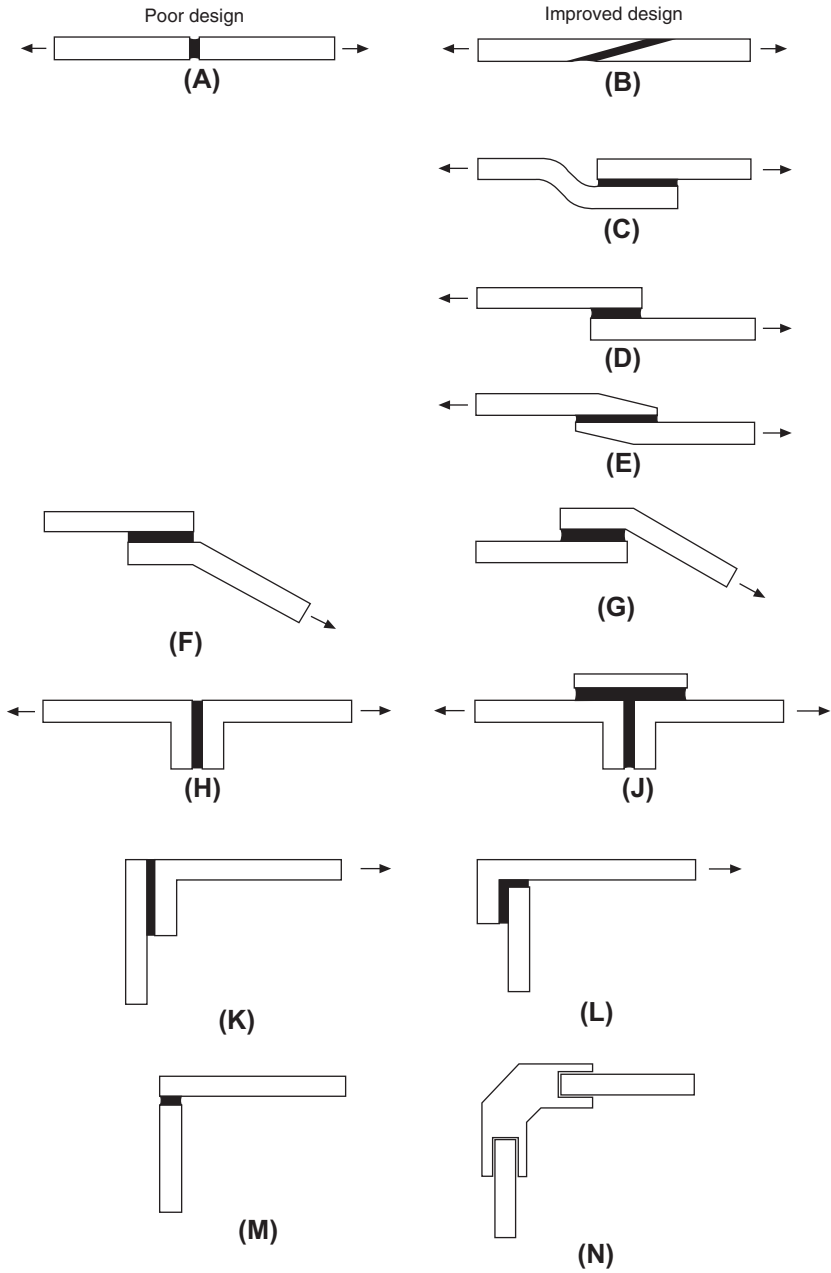
Quite obviously practical considerations involve a study of the forces applicable and acceptable appearance of the finished assembly (Fig. 36.3).

Fig. 36.4 shows two tubular applications.

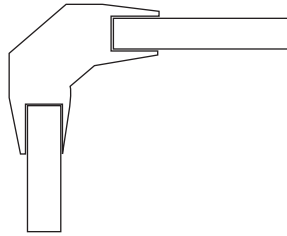
In (a) a cylindrical plug is used to join two tubes in a structure. An example of a tapered tubular joint is given in (b). The taper ensures that the adhesive is not pushed out of the assembly.

The joint permits a long bond line and does not impede fluid flow.

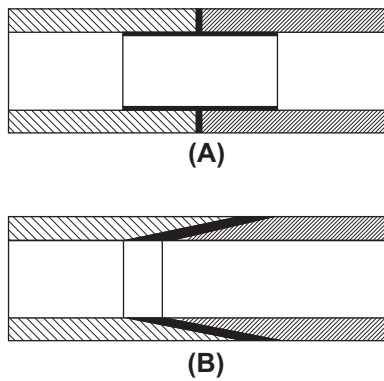
A selection of bonded stiffeners is shown in Fig. 36.5. These can be used to reduce vibration and deflection of thin sheet materials. When the flanges on the stiffened sections deflect with the sheet, little difficulty from the peel results due to the area of the bond. Corrugated backings can provide complete flatness over the entire area. If a corrugated insert is sandwiched between two flat sheets (the second sheet is indicated by dotted lines) as indicated in example (a) then a structure of lightweight and high strength can be manufactured from adhesive bonding. There are many aircraft applications. Standard strip, angles, tee sections, and formed channels are used in structural engineering.



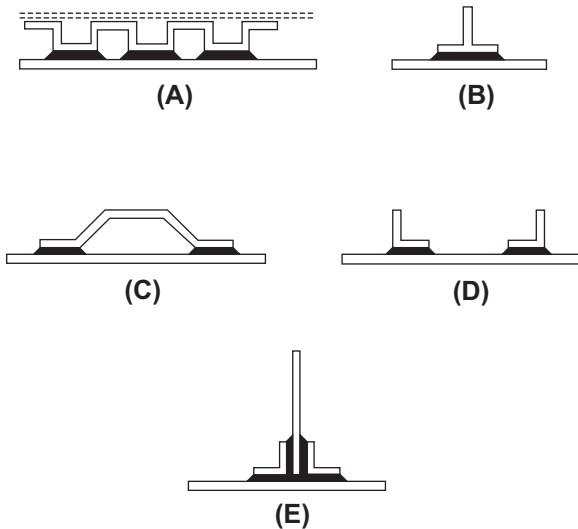
**Fig. 36.2** Typical bonded joints.



**Fig. 36.3** Where slotted joints are used, tapering removes the high-stress concentrations caused by abrupt changes in section. Example gives a possible modification to Fig. 36.2(n).



**Fig. 36.4** Tubular joints



**Fig. 36.5** Examples of bonded stiffeners

The types of adhesive which cover the vast majority of engineering assembly applications come from the following categories.

1. *Epoxies*: Two components are mixed in equal proportions. The adhesive and the hardener begin to cure immediately and have a useable 'pot life'. After this time the bond becomes less effective, often used for DIY repairs. Industry uses an alternative type of epoxy which incorporates rubber of low-molecular weight and is called a 'toughened adhesive'. It has greater resistance to impact forces and peel.
2. *Acrylic adhesives*: Four basic types:
  - (a) *Toughened acrylics*: These are two-part systems where a hardener and an adhesive are applied to the two surfaces being joined and the assembly of the joint automatically mixes them. It can be used on oily steel. It bonds glass into metal frames. It is also used in railway carriage interior panels.
  - (b) *Cyanoacrylate adhesives*: These polymerize (solidify) by a chemical reaction which is usually initiated by atmospheric moisture, present as traces of water on the surfaces to be joined. Successful bonding depends upon ambient humidity, the type of material being bonded, the choice of adhesive, and the nature of the surface. 'Instant adhesives' and 'Superglues' are in this range of products.
  - (c) *Anaerobic adhesives*: These automatically harden in the absence of air and are used mainly in rigid metallic joints. Many applications follow. These products are manufactured normally as single component materials.
  - (d) *UV curing acrylics*: These are single component adhesives where cure is effected rapidly by placing the assembly under an ultraviolet lamp.

These adhesives are applied in the manufacture of printed circuit boards for surface sealing.

3. *Hot melt adhesives*: These are available in rod, sheet and powder forms. It is a convenient method of assembling small components which are lightly loaded. A heating gun raises the temperature of the rod and the adhesive is applied to one component. On cooling, the adhesive solidifies and the two surfaces are bonded together. These adhesives are also used in packaging equipment.
4. *Solvent based contact adhesives*: Here the adhesive is applied in a solvent solution to the two surfaces. The solvent evaporates leaving a tacky film and the surfaces are brought together. Applications include laminated sheet fixings in furniture manufacture.

A considerable range of options is available to the designer in the choice of suitable types of adhesive.

Precision measuring and dispensing is necessary so that the required volume, in the defined position, is applied at a given time and with consistently repeatable accuracy on a production line.

In the interests of satisfactory selection and operation, it is recommended that the manufacturer should be consulted to ensure that all technical considerations have been included in a proposed scheme.

## Engineering applications

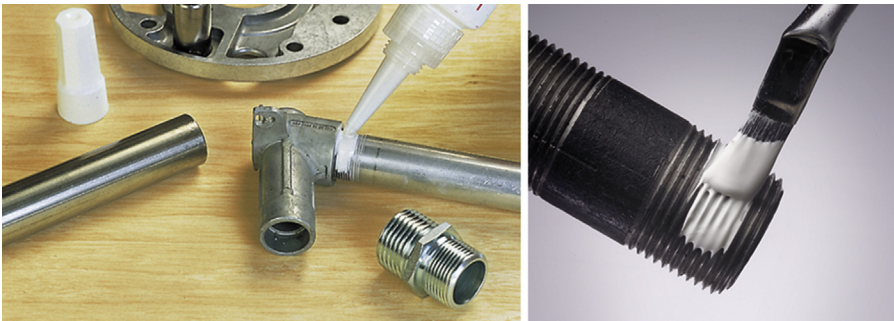
The following examples show varied uses of engineering adhesives in industry.

*Locking screw threads:* The liquid is applied to the cleaned thread of a bolt or stud. When the nut is tightened the liquid fills the gaps between mating threads and hardens to form a tough plastic joint which is shock, vibration, corrosion, and leak proof. The joint will remain in place until it needs to be undone again using normal hand tools (Fig. 36.6).



**Fig. 36.6** Thread locking.

*Threadsealing pipe fittings:* The sealant is applied to the clean thread followed by screwing together as normal. The sealant will not creep or shrink and gives a constant and reliable seal. There is no need to wrench tight and the fitting can be positioned as required (Fig. 36.7).



**Fig. 36.7** Thread sealing (A) Hydraulic sealant for fine threads in pneumatic and hydraulic systems – particularly those subject to vibration. (B) Pipe sealant used to seal coarse threads of pipes and fittings up to 75 mm outside diameter.

*Retaining:* Traditional retaining methods using screws, splines, pins, keys, and press fits, etc., do not necessarily seal joints and eliminate the possibility of corrosion. Local stress concentrations may cause cracking. Retaining adhesives can be used to augment these methods. Often, a redesign will give a replacement with substantial cost savings.

These adhesives are supplied in various strengths:

- (a) High-shear strength adhesives in association with press fits can provide added rigidity.
- (b) Maximum strength retainers are used on parts which generally do not need to be taken apart.
- (c) Medium strength adhesives suit parts which need frequent disassembly (Fig. 36.8).



**Fig. 36.8** Retaining.

*Sealing with anaerobic gaskets:* Gaskets are fitted between flanges to provide an effective seal against fluids and gases. It is cheaper to use a gasket than manufacture two perfectly flat mating surfaces with close flatness and surface finish tolerances.

Gaskets can be preformed from materials such as compressed asbestos, paper, fiber or cork. Alternatively, they can be formed where they are required with a liquid.

The principles of liquid gasketing are fundamentally different from preformed gaskets in that they allow metal-to-metal contact. There are several forms of liquid gasket such as anaerobic, non-setting solvent based and moisture curing.

*The anaerobic principle:* Anaerobic gaskets are available in a range of viscosities from thick liquids to non-slump pastes. Each can be applied directly from the original container, or by various application methods such as simple rollers, screen printing and computerized robotics. On assembly, the anaerobic gasket spreads between the flanges and is forced into surface irregularities to provide total contact between the two faces. The product then polymerizes at ambient temperature into a tough thermoset plastic.

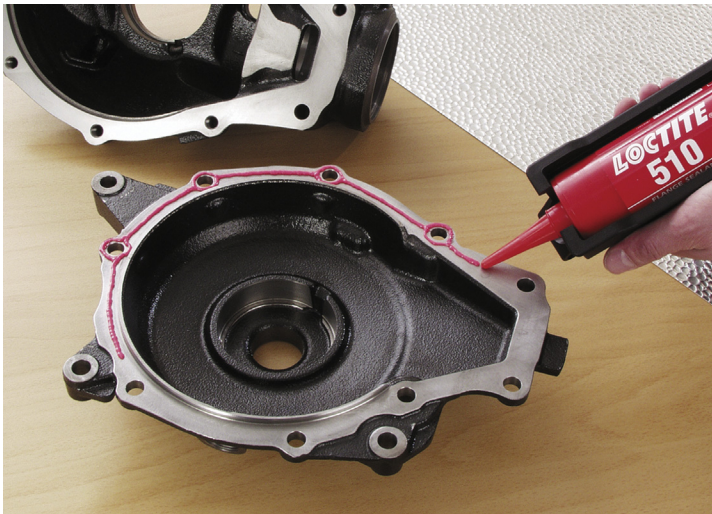
The strength of joints from anaerobics can be tailored to suit a specific application. Effective cure requires the absence of air and the presence of metal. At room temperature it takes just a few minutes.

*Note:* Anaerobic gaskets are thermosetting plastics; the temperature range in service can be from  $-50\text{ }^{\circ}\text{C}$  up to  $200\text{ }^{\circ}\text{C}$  at the joint line. They seal against petroleum based fuels and lubricating oils, water/glycol mixtures and many other industrial chemicals. For compatibility of specific chemical environments the designer would be advised to consult the manufacturers.

Although anaerobic gaskets permit metal-to-metal contact, electrical continuity cannot be assumed.

Fig. 36.9 shows the application of an anaerobic gasket to one half of a gearbox housing.

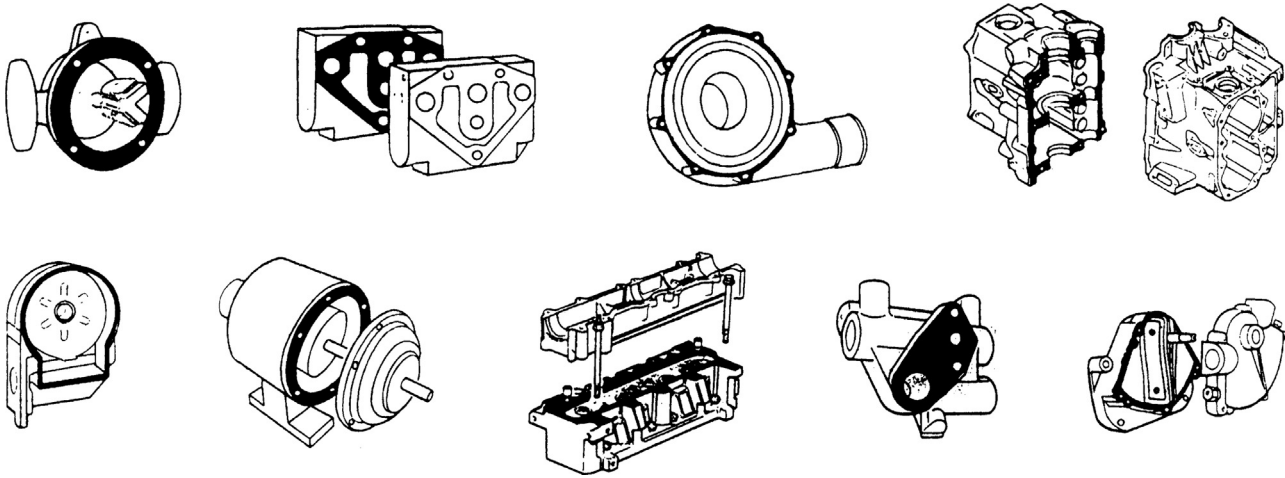
It often happens during maintenance work that damaged or scored surfaces are found and an adhesive gasket can save the need and cost of re-machining.



**Fig. 36.9** Application of an anaerobic gasket.

Engineering adhesives for sealing flat faces have the following characteristics and applications.

- (a) They will seal on horizontal, vertical and overhead flanges and accommodate surface irregularities of up to 0.5 mm.
- (b) Low-strength products are available for close fitting surfaces which will be frequently dismantled.
- (c) In the illustrations in Fig. 36.10 many of the components are manufactured in aluminum alloys. The structural integrity of an assembly can be enhanced by the use of high-shear strength adhesives.



**Fig. 36.10** Examples of the application of high shear-strength adhesives.

Engineering adhesives for retaining cylindrical assemblies have the following characteristics and applications:

- (a) The retention of shafts and rotors of electric motors, gears, pulleys, sleeves, bushes, and oil seals in housings.
- (b) The ability to withstand fatigue and augment torsional strength.
- (c) Suitable for parts that need easy disassembly, such as bearings on shafts and in housings, bushes and journals in soft metals.
- (d) An oil-tolerant adhesive is available that gives high-strength retention of parts 'as received', i.e. no cleaning is needed before assembly. Oil impregnated bushes are retained with this grade. They are manufactured by the sintering process.
- (e) An adhesive can be recommended for continuous working temperatures up to 175 °C. It combines the ability to fill gaps of up to 0.15 mm in diameter with high-shear strength and good solvent resistance.

## Instant adhesives

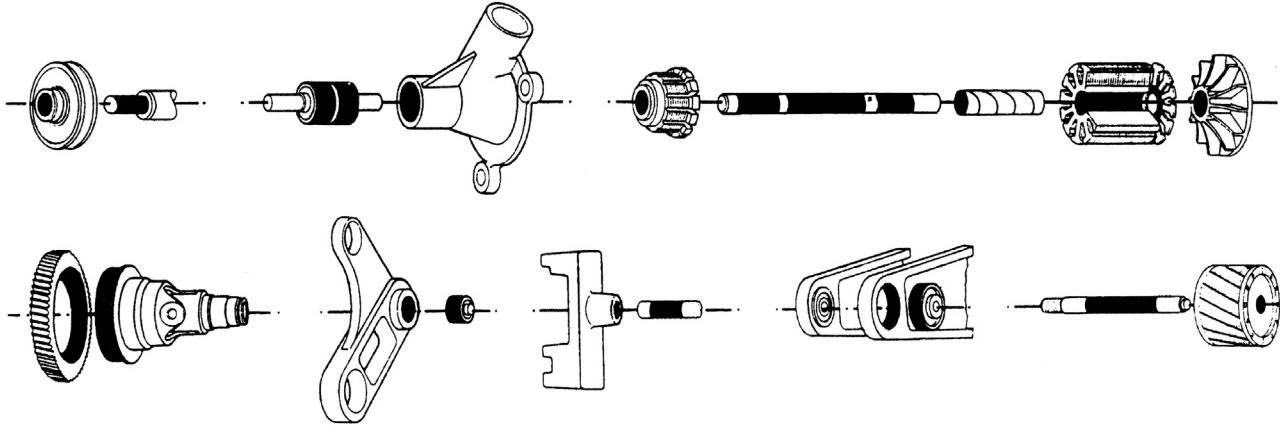
As the name suggests, they work in seconds and are ideal for bonding close fitting parts made from a variety of materials. They offer advantages over other forms of joining, such as plastic welding, two-part or heat-cured adhesives and mechanical fasteners. The benefits include faster assembly times, better appearance, and less outlay for capital equipment, and these adhesives can also be used to repair metal, plastic, rubber or ceramic components which might otherwise be scrapped.

Instant adhesives are available for the following applications:

- (a) General purpose adhesive for plated metals, composite materials, wood, cork, foam, leather, paper – all surfaces which were once considered 'difficult' can now be bonded quickly and permanently.
- (b) A special rubber and plastics adhesive ensures fast-fixturing of elastomers and rubbers, especially EPDM rubber. It bonds polyethylene, polypropylene and polyolefin plastics.
- (c) A gel-type adhesive can be used for fabrics, paper, phenolic, PVC, neoprene and nitrile rubber and bond them in 5 s; for ceramic, leather, and balsa wood (10 s); for mild steel (20 s); for ABS and pine (30 s). The gel form prevents absorption by porous materials and enables it to be applied to overhead and vertical surfaces without running or dripping.
- (d) A low-odour, low-bloom adhesive has been developed where application vapors have been removed with no possibility of contamination. A cosmetically perfect appearance can be obtained. The absence of fumes during application means that it can be safely used close to delicate electrical and electronic assemblies, alongside optics and in unventilated spaces.
- (e) A black rubber toughened instant adhesive gives superior resistance to peel and shock loads. Tests show bonds on grit blasted mild steel can expect a peel strength of 4 N/mm at full cure.

All adhesives can be applied direct from bottle, tube or standard automatic application equipment on to surfaces which require very little pretreatment.

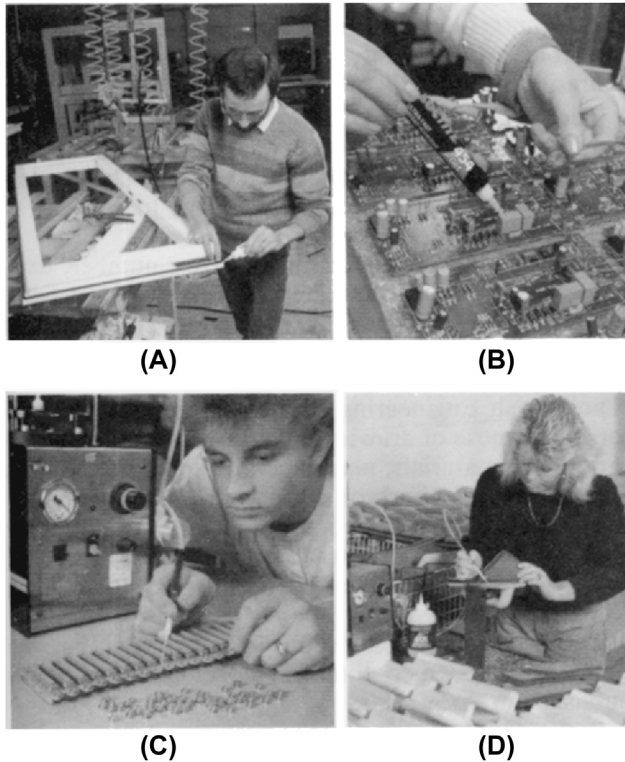
In most cases, just one drop of instant adhesive is enough to form an extremely strong, virtually unbreakable bond. There is no adhesive mixing, and cure takes place in seconds to give a joint with maximum surface-to-surface contact (Fig. 36.11).



**Fig. 36.11** Examples of the application of instant adhesive.

Four typical production applications are shown in Fig. 36.12.

The illustration in Fig. 36.12C shows an operator using a semi-automatic dispenser. The bonding product is contained in a bottle pack; dispensing is regulated by an electronic timer controlled pinch valve mounted on the unit. The dispense function can be initiated in a variety of ways, including a footswitch. The point of application is controlled by hand.



**Fig. 36.12** (A) Bonding rubber to uPVC double glazing units, (B) bonding toroid to the PCB from a temperature control unit, (C) bonding brass to PVC on a connector and (D) bonding foam rubber to molded polyurethane grouting tool.

## Structural applications

Structural adhesives are ideal for bonding large areas of sheet materials. They can produce a much better finished appearance to an assembly than, say, rivets, or spot welding or screws. The local stress introduced at each fixing point will be eliminated. Furthermore, adhesives prevent the corrosion problems normally associated with joining dissimilar materials. This is a cost-effective method of providing high-strength joints (Figs. 36.13 and 36.14).



**Fig. 36.13** A structural adhesive used to bond a stiffener to an aluminum car bonnet. To line up the two parts a purpose made fixture is designed.



**Fig. 36.14** Mild steel stiffeners are bonded to up and over garage door. Result: rigidity; unblemished exterior surfaces.

EN ISO 15,785 Technical drawings – Symbolic presentation and indication of adhesive, fold and pressed joints. This Standard includes examples of graphical symbols, indication of joints in drawings, basic conventions for symbolic presentation, and indication of joints. Also included are designation examples and the dimensioning of graphical symbols.

The authors wish to express their thanks for the assistance given, and permission to include examples showing the application of adhesives in this chapter, by Loctite UK – [www.loctite.co.uk](http://www.loctite.co.uk).

Standards are essential tools for industry and commerce, influencing every aspect of the industrial process. They provide the basic ingredients for competitive and cost-effective production. Standards define criteria for materials, products and procedures in precise, authoritative and publicly available documents. They embrace product and performance specifications; codes of practice; management systems; methods of testing, measurement, analysis and sampling; guides; and glossaries.

Thus they facilitate design and manufacture by:

- establishing safety criteria;
- promoting quality with economy;
- assisting communication and trade; and
- inspiring confidence in manufacturer and user.

The role of Standards in national economic life is expanding. They are:

- increasingly referred to in contracts;
- called up in national and community legislation;
- used as a basis for quality management;
- required for product certification;
- required in public purchasing; and are used as a marketing tool.

## The British Standards institution

Established in 1901, The BSI was the world's first national Standards body. Many similar organizations worldwide now belong to the International Organization for Standardization (ISO) and the International Electrotechnical Commission (IEC). BSI represents the views of British Industry on these bodies, working toward harmonizing world Standards.

BSI has published approximately 20 000 Standards; each year around 2000 new and revised Standards are issued to encompass new materials, processes and technologies, and to keep the technical content of existing Standards current. BSI also provides services to its members and undertakes commercial activities, which help underwrite its core Standards role.

The BSI Catalog is published each year. BSI subscribing membership is designed to make keeping in touch with developments in world standardization easy and cost-effective. Membership benefits include:

- discounts on products and services;
- free Standards catalog, BSI magazines and use of the library;

- access to PLUS (see below) licensed electronic products;
- library loans, credit facilities, loans, Members Days and AGM voting rights.

## **BSI knowledge center**

This contains over half a million Standards as well as other reference material including documents on code of practice and technical requirements. Electronic access to many more documents are also available. These include, British Standards, National Standards, and European and International adoptions, ISO IEC, CEN, and CENELEC Standards, as well as Standards published by other National Standard bodies in Europe and worldwide, such as DIN, ANSI, JIS, GOST and many more.

## **Technical information group**

For over 30 years BSI has run a technical help to exporters service and now covers more subjects and more countries than ever before. Technical barriers to trade (Standards, regulations, certification and language) affect products in worldwide markets. BSI can support market research activities in a cost-effective and timely way. For more information log on to [www.bsi-global.com/export](http://www.bsi-global.com/export).

## **Foreign standards and translations**

BSI holds over 100 000 international and foreign Standards and regulations in their original form, as well as expert translations that are regularly reviewed to ensure they are current. New translations from and into most languages can be arranged on request.

## **PLUS — private list updating service**

PLUS monitors and automatically updates your Standards collection. Exclusive to BSI subscribing members, PLUS not only saves time and effort, but can be an essential part of your quality control system.

## **Perinorm**

Perinorm is the world's leading bibliographic database of Standards. Available either on CD-ROM or online at [www.perinorm.com](http://www.perinorm.com), Perinorm contains approximately 520 000 records, including technical regulations from France and Germany, together with American, Australian, and Japanese Standards (international version).

## DISC

DISC – Delivering Information Solutions to Customers through international standardization – is the specialist IT arm of BSI. It enables UK businesses to exert influence when international Standards are being formulated and responds directly by helping customers to use Standards. It offers guidance, codes of practice, seminars and training workshops.

## British Standards Online and CD-ROM

British Standards Publishing Ltd supplies British Standards worldwide in hard copy, on CD-ROM and on the Internet via British Standards Online. The exclusive, authoritative and most current source of British Standards delivers information on more than 38 000 BSI publications to your desktop. For more information on delivery options for British Standards contact:

UK customers: British Standards Publishing Sales Ltd; Email: [bsonline@techindex.co.uk](mailto:bsonline@techindex.co.uk)  
Customers outside the UK: Information Handling Services; Email: [info@ihs.com](mailto:info@ihs.com)

BSI quality assurance is the largest independent certification body in the UK and provides a comprehensive service including certification, registration, assessment, and inspection activities.

BSI testing at Hemel Hempstead offers services which are completely confidential and covers test work in many areas including product safety, medical equipment, motor vehicle safety equipment, and calibration work. Tests are undertaken to national or international Standards.

Further information on BSI services can be obtained from [www.BSI.global.com](http://www.BSI.global.com).

Complete sets of British Standards are maintained for reference purposes at many Public, Borough and County Libraries in the UK. Copies are also available in University and College of Technology Libraries.

## The Standards-making process

The BSI Standards' function is to draw up voluntary Standards in a balanced and transparent manner, to reach agreement among all the many interests concerned, and to promote their adoption. Technical committees whose members are nominated by manufacturers, trade and research associations, professional bodies, central and local government, academic bodies, and user and consumer groups, draft Standards.

BSI arranges the secretariats and takes care to ensure that its committees are representative of the interests involved. Members and Chairmen of committees are funded by their own organizations.

Proposals for new and revised Standards come from many sources but the largest proportion is from industry. Each proposal is carefully examined against its contribution to national needs, existing work programs, the availability of internal and external resources, the availability of an initial draft and the required timescale to publish the Standard. If the work is accepted it is allocated to a relevant existing technical committee or a new committee is constituted.

Informed criticism and constructive comment during the committee stage are particularly important for maximum impact on the structure and content of the future Standard.

The draft Standards are made available for public comment and the committee considers any proposals made at this stage. A Standard is adopted when the necessary consensus for its application has been reached.

Strategy, policy, work programs and resource requirements are formulated and managed by Councils and Policy Committees covering all sectors of industry and commerce.

## **International Organization for Standardization (ISO)**

### ***What ISO offers***

ISO is made up of national Standards institutes from countries large and small, industrialized and developing, in all regions of the world. ISO develops voluntary technical Standards, which add value to all types of business operations. They contribute to making the development, manufacturing and supply of products and services more efficient, safer and cleaner. They make trade between countries easier and fairer. ISO Standards also serve to safeguard consumers, and users in general, of products and services — as well as making their lives simpler.

### ***ISO's name***

Because the name of the International Organization for Standardization would have different abbreviations in different languages (ISO in English, OIN in French), it was decided to use a word derived from the Greek ISOS, meaning 'equal'. Therefore, the short form of the Organization's name is always ISO.

### ***How it started***

International standardization began in the electrotechnical field: the International Electrotechnical Commission (IEC) was established in 1906. Pioneering work in other fields was carried out by the International Federation of the National Standardizing Associations (ISA), which was set up in 1926. The emphasis within ISA was laid heavily on mechanical engineering. ISA's activities came to an end in 1942.

In 1946, delegates from 25 countries met in London and decided to create a new international organization, of which the object would be 'to facilitate the international coordination and unification of industrial Standards'. The new organization, ISO, officially began operating on 23 February 1947. ISO currently has some 140-member organizations on the basis of one member per country. ISO is a non-governmental organization and its members are not, therefore, national governments, but are the Standards institutes in their respective countries.

Every participating member has the right to take part in the development of any Standard which it judges to be important to its country's economy. No matter what the size or strength of that economy, each participating member in ISO has one vote. ISO's activities are thus carried out in a democratic framework where each country is on an equal footing to influence the direction of ISO's work at the strategic level, as well as the technical content of its individual Standards. ISO Standards are voluntary. ISO does not enforce their implementation. A certain percentage of ISO Standards — mainly those concerned with health, safety or the environment — has been adopted in some countries as part of their regulatory framework, or is referred to in legislation for which it serves as the technical basis. However, such adoptions are sovereign decisions by the regulatory authorities or governments of the countries concerned. ISO itself does not regulate or legislate.

ISO Standards are market-driven. They are developed by international consensus among experts drawn from the industrial, technical or business sectors, which have expressed the need for a particular Standard. These experts may be joined by these from government, regulatory authorities, testing bodies, academia, consumer groups or other organizations with relevant knowledge, or from these which have expressed a direct interest in the Standard under development. Although ISO Standards are voluntary, the fact that they are developed in response to market demand, and are based on consensus among the interested parties, ensures widespread use of the Standards.

ISO Standards are technical agreements which provide the framework for compatible technology worldwide. Developing technical consensus on the international scale is a major operation. This technical work is coordinated from ISO Central Secretariat in Geneva, which also publishes the Standards.

### ***Quantity and quality***

Since 1947, ISO has published some 13 000 International Standards. ISO's work program ranges from Standards for traditional activities, such as agriculture and construction, through mechanical engineering to the newest information technology developments, such as the digital coding of audio-visual signals for multimedia applications.

Standardization of screw threads helps to keep chairs, children's bicycles and aircraft together and solves the repair and maintenance problems, caused by a lack of standardization, that were once a major headache for manufacturers and product users. Standards establishing an international consensus on terminology make

technology transfer easier and can represent an important stage in the advancement of new technologies.

Without the standardized dimensions of freight containers, international trade would be slower and more expensive. Without the standardization of telephone and banking cards, life would be more complicated. A lack of standardization may even affect the quality of life itself – for the disabled, for example, when they are barred access to consumer products, public transport and buildings because the dimensions of wheelchairs and entrances are not standardized. Standardized symbols provide danger warnings and information across linguistic frontiers. Consensus on grades of various materials gives a common reference for suppliers and clients in business dealings.

Agreement on a sufficient number of variations of a product to meet most current applications allows economies of scale with cost benefits for both producers and consumers. An example is the standardization of paper sizes. Standardization of performance or safety requirements of diverse equipment makes sure that users' needs are met while allowing individual manufacturers the freedom to design their own solution on how to meet those needs. Consumers then have a choice of products, which nevertheless meet basic requirements, and they benefit from the effects of competition among manufacturers.

Standardized protocols allow computers from different vendors to 'talk' to each other. Standardized documents speed up the transit of goods, or identify sensitive or dangerous cargoes that may be handled by people speaking different languages. Standardization of connections and interfaces of all types ensures the compatibility of equipment of diverse origins and the interoperability of different technologies.

Agreement on test methods allows meaningful comparisons of products, or plays an important part in controlling pollution – whether by noise, vibration or emissions. Safety Standards for machinery protect people at work, at play, at sea ... and at the dentist's. Without the international agreement contained in ISO Standards on quantities and units, shopping and trade would be haphazard, science would be – well, unscientific – and technological development would be handicapped.

Tens of thousands of businesses in more than 150 countries are implementing ISO 9000, which provides a framework for quality management and quality assurance throughout the processes of producing and delivering products and services for the customer.

### **Conformity assessment**

It is not the role of ISO to verify that ISO Standards are being implemented by users in conformity with the requirements of the Standards. *Conformity assessment* – as this verification process is known – is a matter for suppliers and their clients in the private sector, and of regulatory bodies when ISO Standards have been incorporated into public legislation. In addition, there exist many testing laboratories and auditing bodies, which offer independent (also known as *third party*) conformity assessment services

to verify that products, services or systems measure up to ISO Standards. Such organizations may perform these services under a mandate to a regulatory authority, or as a commercial activity of which the aim is to create confidence between suppliers and their clients.

However, ISO develops ISO/IEC guides and Standards to be used by organizations which carry out conformity assessment activities. The voluntary criteria contained in these guides represent an international consensus on what constitutes best practice. Their use contributes to the consistency and coherence of conformity assessment worldwide and so facilitates trade across borders.

## ***Certification***

When a product, service, or system has been assessed by a competent authority as conforming to the requirements of a relevant Standard, a certificate may be issued as proof. For example, many thousands of ISO 9000 certificates have been issued to businesses around the world attesting to the fact that a quality management system operated by the company concerned conforms to one of the ISO 9000 Standards. Likewise, more and more companies now seek certification of their environmental management systems to the ISO 14,001 Standard. ISO itself does not carry out certification to its management system Standards and it does not issue either ISO 9000 or ISO 14,000 certificates.

To sum up, ISO Standards are market-driven. They are developed on the basis of international consensus among experts from the sector which has expressed a requirement for a particular Standard. Since ISO Standards are voluntary, they are used to the extent that people find them useful. In cases like ISO 9000 – which is the most visible current example, but not the only one – that can mean very useful indeed!

## ***The ISO catalog***

The ISO catalog is published annually. The catalog for example, contains a list of all currently valid ISO Standards and other publications issued up to 31 December of the previous year.

The Standards are presented by subject according to the International Classification for Standards (ICS).

Lists in numerical order and in technical committee order are also given. In addition, there is an alphabetical index and a list of Standards withdrawn. Requests for information concerning the work of ISO should be addressed to the ISO Central Secretariat or to any of the National Member Bodies listed below:

ISO Central Secretariat  
1, rue de Varembe  
Case postale 56  
CH-1211 Geneve 20  
Switzerland email: [central@iso.ch](mailto:central@iso.ch)

[www.iso.ch](http://www.iso.ch)

**ISO/IEC Information Center**

e-mail [mbinfo@iso.ch](mailto:mbinfo@iso.ch)

[www.standsinfo.net](http://www.standsinfo.net)

Sales department email: [sales@iso.ch](mailto:sales@iso.ch)

**ISO membership**

The 162 member bodies listed in [Table 37.1](#), which are divided into three categories of member bodies (M), correspondent members (C) and subscriber members (S), constitute the membership of the International Standards Organization. For up-to-date member details see the ISO web page: [www.iso.org/iso/about/iso\\_members.htm](http://www.iso.org/iso/about/iso_members.htm).

**Table 37.1** ISO member countries.

Country	Acronym	Status
Afghanistan	ANSA	C
Albania	DPS	C
Algeria	IANOR	M
Angola	IANORQ	C
Antigua and Barbuda	ABBS	S
Argentina	IRAM	M
Armenia	SARM	M
Australia	SA	M
Austria	ASI	M
Azerbaijan	AZSTAND	M
Bahrain	BSMD	M
Bangladesh	BSTI	M
Barbados	BNSI	M
Belarus	BELST	M
Belgium	NBN	M
Benin	ABENOR	C
Bhutan	BSB	C
Bolivia	IBNORCA	C
Bosnia and Herzegovina	BAS	M
Botswana	BOBS	M
Brazil	ABNT	M
Brunei Darussalam	CPRU	C
Bulgaria	BDS	M

**Table 37.1** ISO member countries.—cont'd

<b>Country</b>	<b>Acronym</b>	<b>Status</b>
Burkina Faso	FASONORM	C
Burundi	BBN	S
Cambodia	ISC	S
Cameroon	ANOR	M
Canada	SCC	M
Central African Republic	SNQCA	S
Chile	INN	M
China	SAC	M
Colombia	ICONTEC	M
Congo, the democratic republic of the	OCC	M
Congo, the republic of the	ACONOR	C
Costa Rica	INTECO	M
Côte d'Ivoire	CODINORM	M
Croatia	HZN	M
Cuba	NC	M
Cyprus	CYS	M
Czech republic	UNMZ	M
Denmark	DS	M
Dominica	DBOS	S
Dominican Republic	DIGENOR	C
Ecuador	INEN	M
Egypt	EOS	M
El Salvador	CONACYT	C
Eritrea	ESI	S
Estonia	EVS	M
Ethiopia	ESA	M
Fiji	FTSQCO	M
Finland	SFS	M
France	AFNOR	M
Gabon	ANTT	C
Gambia	GAMSFP	C

*Continued*

**Table 37.1** ISO member countries.—cont'd

<b>Country</b>	<b>Acronym</b>	<b>Status</b>
Georgia	GEOSTM	C
Germany	DIN	M
Ghana	GSB	M
Greece	ELOT	M
Guatemala	COGUANOR	C
Guinea	IGNM	C
Guyana	GNBS	S
Honduras	DGCI	S
Hong Kong, China	ITCHK SAR	C
Hungary	MSZT	M
Iceland	IST	M
India	BIS	M
Indonesia	BSN	M
Iran, Islamic republic of	ISIRI	M
Iraq	COSQC	M
Ireland	NSAI	M
Israel	SII	M
Italy	UNI	M
Jamaica	BSJ	M
Japan	JISC	M
Jordan	JSMO	M
Kazakhstan	KAZMEMST	M
Kenya	KEBS	M
Korea, democratic People's republic	CSK	M
Korea, republic of	KATS	M
Kuwait	KOWSMD	M
Kyrgyzstan	KYRGYZST	C
Lao People's democratic rep.	DISM	S
Latvia	LVS	C
Lebanon	LIBNOR	M
Lesotho	LSQAS	C

**Table 37.1** ISO member countries.—cont'd

<b>Country</b>	<b>Acronym</b>	<b>Status</b>
Liberia	LDS	C
Libyan Arab Jamahiriya	LNCSM	M
Lithuania	LST	M
Luxembourg	ILNAS	M
Macau, China	CPTTM	C
Madagascar	BNM	C
Malawi	MBS	C
Malaysia	DSM	M
Mali	MLIDNI	M
Malta	MCCAA	M
Mauritania	DNPQ	C
Mauritius	MSB	M
Mexico	DGN	M
Moldova, republic of	INSM	C
Mongolia	MASM	M
Montenegro	ISME	C
Morocco	IMANOR	M
Mozambique	INNOQ	C
Myanmar	MSTRD	C
Namibia	NSI	M
Nepal	NBSM	C
Netherlands	NEN	M
New Zealand	SNZ	M
Nigeria	SON	M
Norway	SN	M
Oman	DGSM	M
Pakistan	PSQCA	M
Palestine	PSI	C
Panama	COPANIT	M
Papua New Guinea	NISIT	C
Paraguay	INTN	C

*Continued*

**Table 37.1** ISO member countries.—cont'd

<b>Country</b>	<b>Acronym</b>	<b>Status</b>
Peru	INDECOPI	M
Philippines	BPS	M
Poland	PKN	M
Portugal	IPQ	M
Qatar	QS	M
Romania	ASRO	M
Russian Federation	GOST R	M
Rwanda	RBS	C
Saint Lucia	SLBS	M
Saint Vincent and the Grenadines	SVGBS	S
Saudi Arabia	SASO	M
Senegal	ASN	M
Serbia	ISS	M
Seychelles	SBS	C
Sierra Leone	SLSB	C
Singapore	SPRING SG	M
Slovakia	SUTN	M
Slovenia	SIST	M
South Africa	SABS	M
Spain	AENOR	M
Sri Lanka	SLSI	M
Sudan	SSMO	M
Suriname	SSB	C
Swaziland	SWASA	C
Sweden	SIS	M
Switzerland	SNV	M
Syrian Arab Republic	SASMO	M
Tajikistan	TJKSTN	C
Tanzania, United republic of	TBS	M
Thailand	TISI	M
The former Yugoslav republic of Macedonia	ISRM	M

**Table 37.1** ISO member countries.—cont'd

<b>Country</b>	<b>Acronym</b>	<b>Status</b>
Trinidad and Tobago	TTBS	M
Tunisia	INNORPI	M
Turkey	TSE	M
Turkmenistan	MSST	C
Uganda	UNBS	C
Ukraine	DSSU	M
United Arab Emirates	ESMA	M
United Kingdom	BSI	M
Uruguay	UNIT	M
USA	ANSI	M
Uzbekistan	UZSTANDARD	M
Vietnam	STAMEQ	M
Yemen	YSMO	M
Zambia	ZABS	C
Zimbabwe	SAZ	M

The following three typical drawings are included as examples of draughting, layout, dimensioning, and tolerancing.

Figs. 38.1 and 38.2 show a pulley and a shaft, and illustrate some aspects of general dimensioning and tolerancing.

Fig. 38.3 shows a partly dimensioned elevation and plan view of a proposed gear-box cover, with a wide application of theoretically exact (boxed) dimensioning and the associated positional tolerances. To emphasize this style of dimensioning, other dimensions relating to the form of the cover have been omitted.

Completed drawings are usually presented on company standard sheets. Sizes, areas and designations are given at the start of Chapter 7. The layout of a typical sheet contains information required for identification, administration and interpretation and a company could design several types of standard sheets, particularly appropriate to their products.

If drawings are produced manually, then the drawing sheets may be supplied with printed borders and blocks containing relevant notes and headings. With computer aided design (CAD) layouts, similar details are stored in the database.

Figs. 38.4–38.7 clearly show that documentation can occupy much of the sheet area. The space provided for basic and supplementary information will be decided by the company; its actual position on the sheet may vary with the sheet size.

Engineering progress over the years has resulted in the issue of many Standards and clearly there are literally millions of drawings in circulation, which may contain minor details that have been superseded. It has been the custom in a drawing title block to record a brief note of dates when changes and modifications have occurred. A typical drawing number could be known as, for example: HB 345 for the original issue; then HB 345A for the first reissue, HB 345B for the second reissue, etc. A brief note may be added to the drawing relating to the change. Each manufacturer will have their own system for recording full details and also advising current users that a change has occurred.

Examples are shown on some of the following illustrations.

In the case of textbooks, the front page generally states the publishing dates and obviously general standards used are appropriate to that date. Illustrations of typical layouts are reproduced by kind permission of Delphi Diesel Systems.

An advantage of producing a drawing on a CAD system is that the designer can complete the illustration of the component or assembly on the screen. They may reposition some parts if space permits, to avoid congestion. The outline of the drawing sheet will be taken from the database on a separate layer and placed over the drawing to give a pleasing layout.

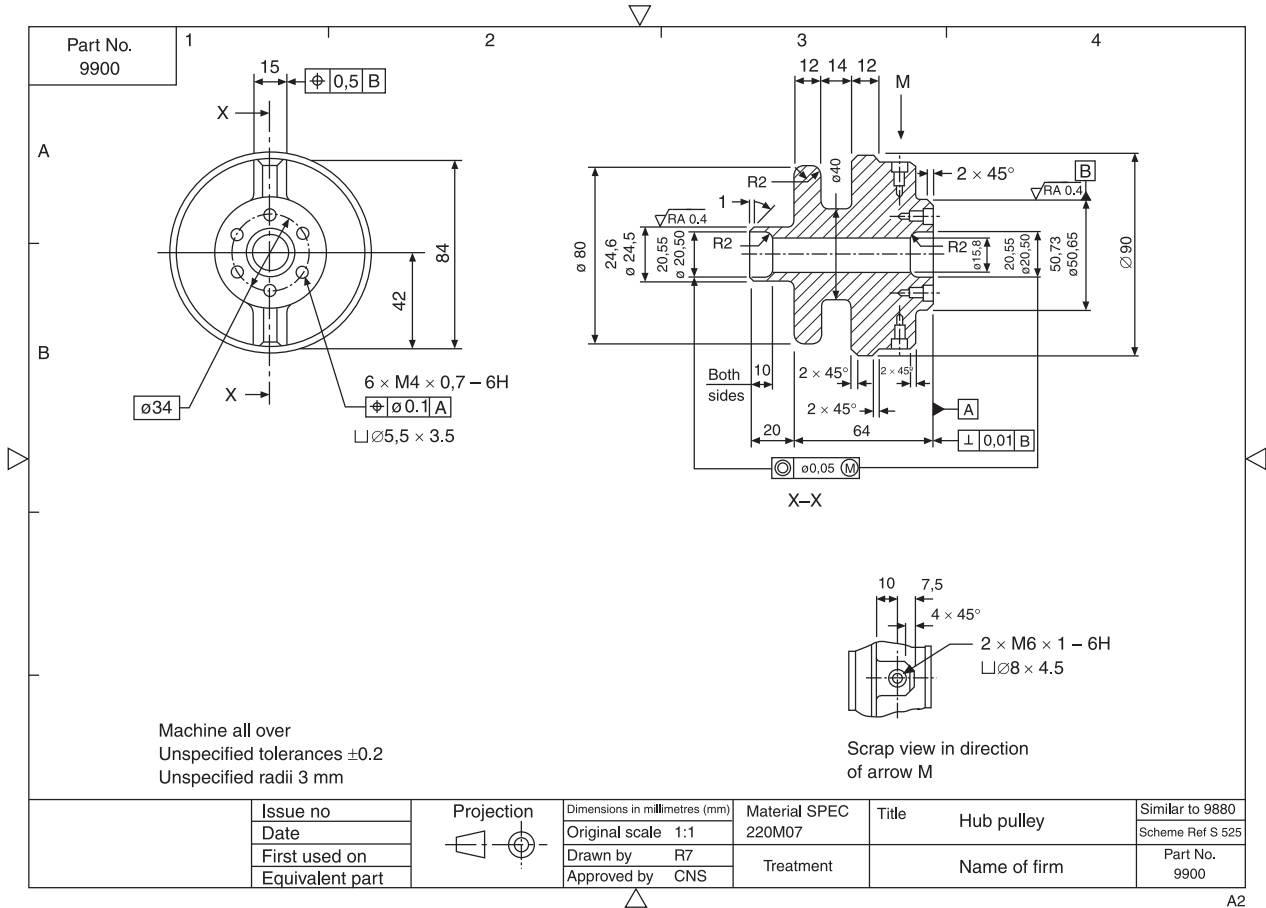


Fig. 38.1 Pulley - showing general aspects of dimensioning.

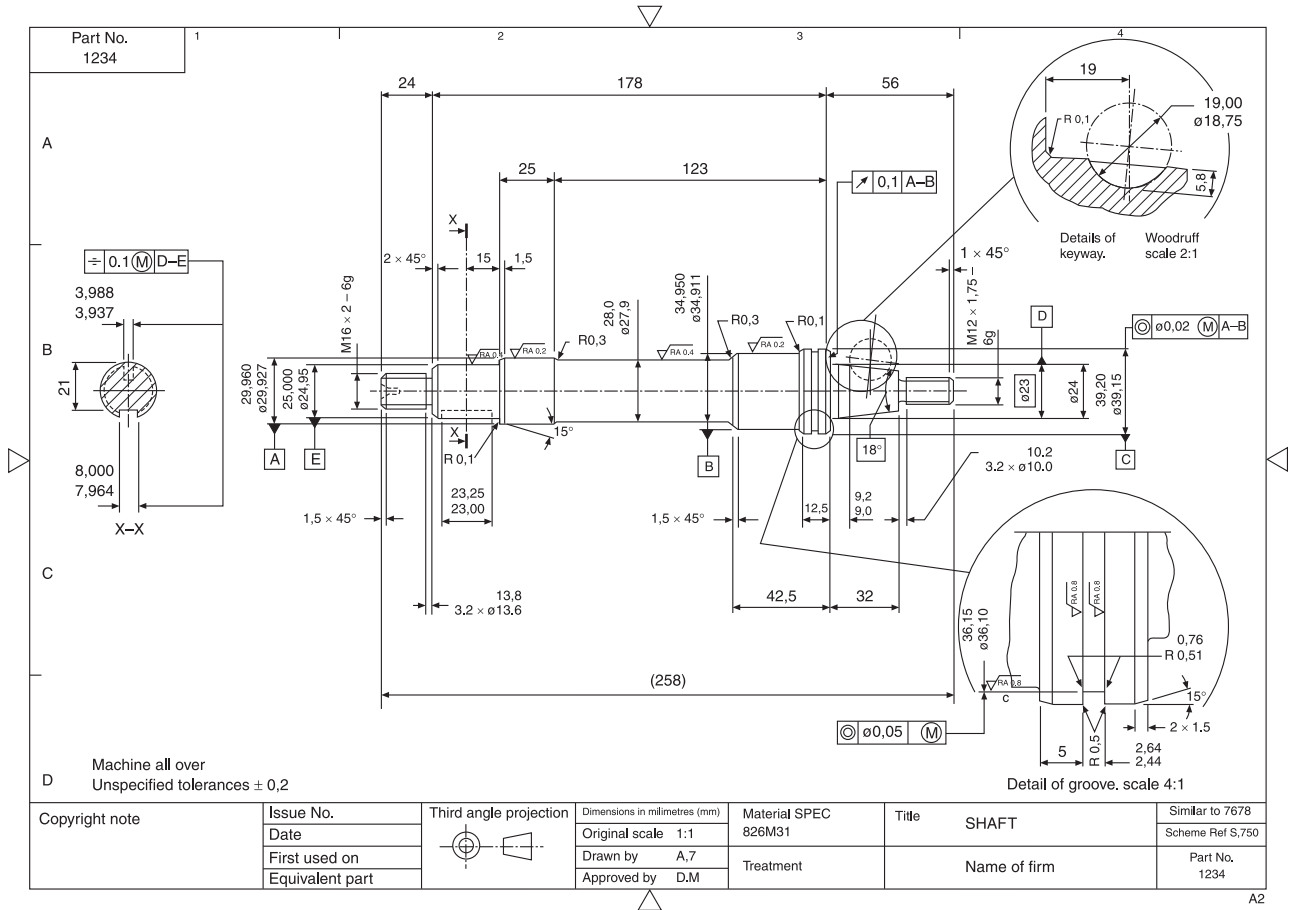


Fig. 38.2 Shaft - showing general aspects of dimensioning.

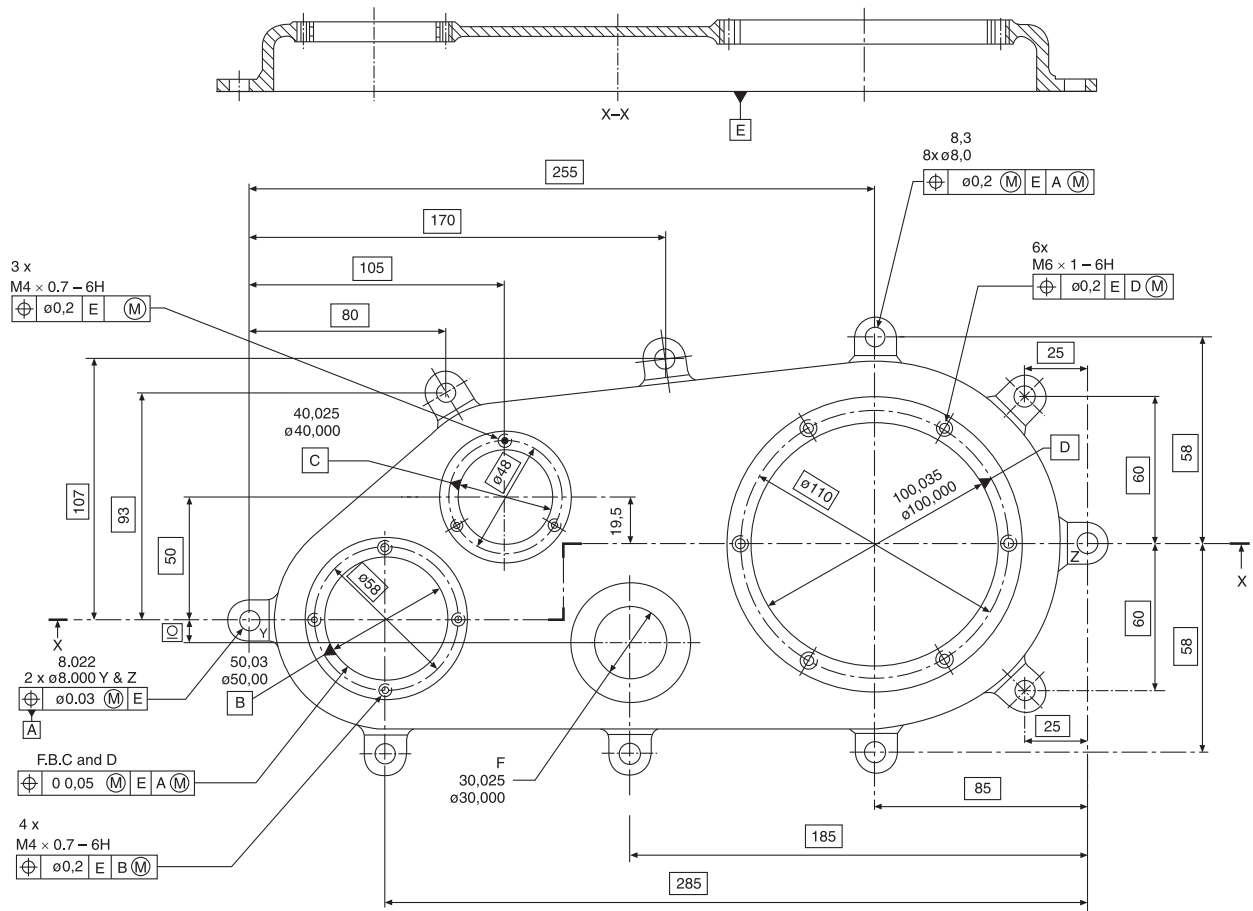


Fig. 38.3 Elevation and plan view of a gear box cover with theoretical exact dimensions applied.

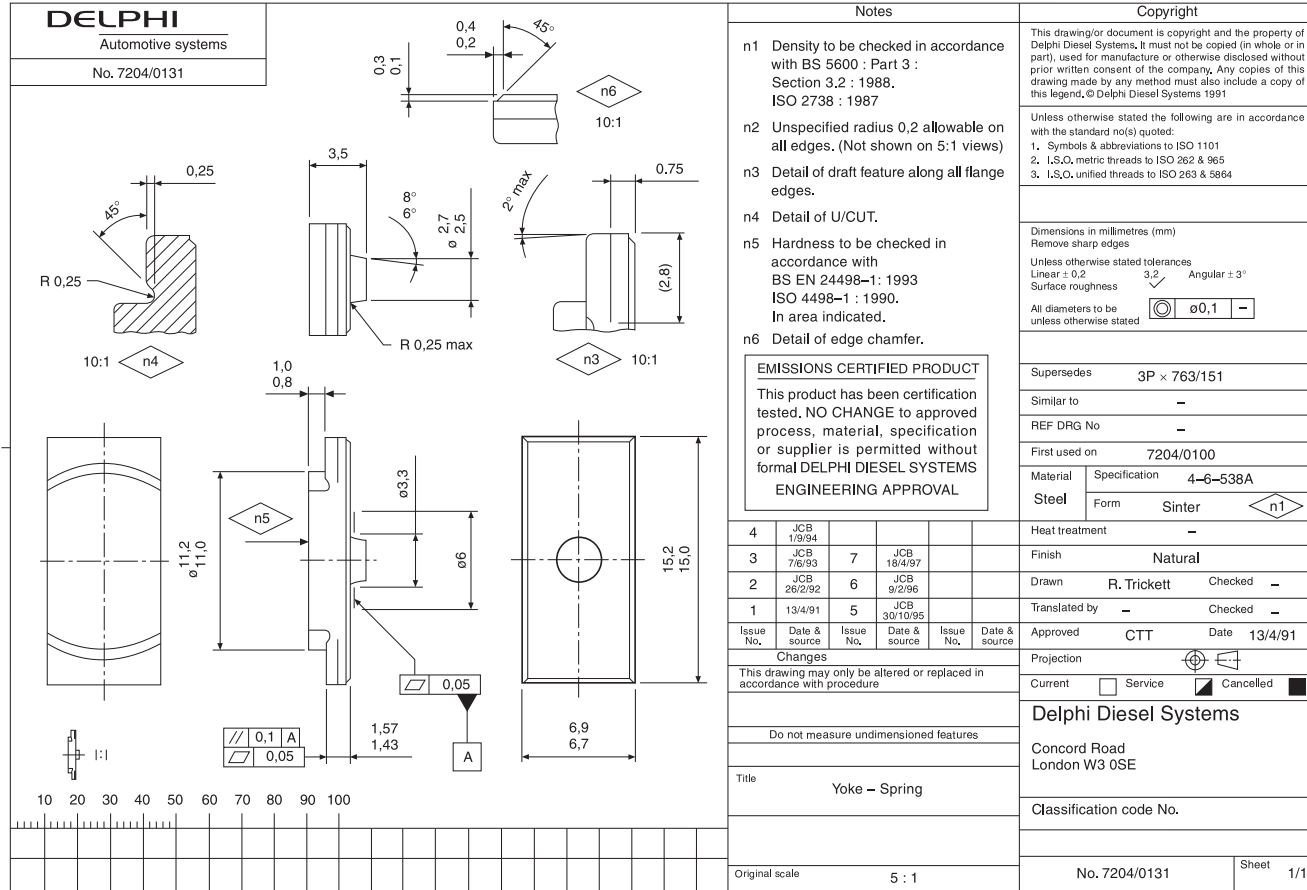


Fig. 38.4 Example of supplemental documentation on a drawing sheet.

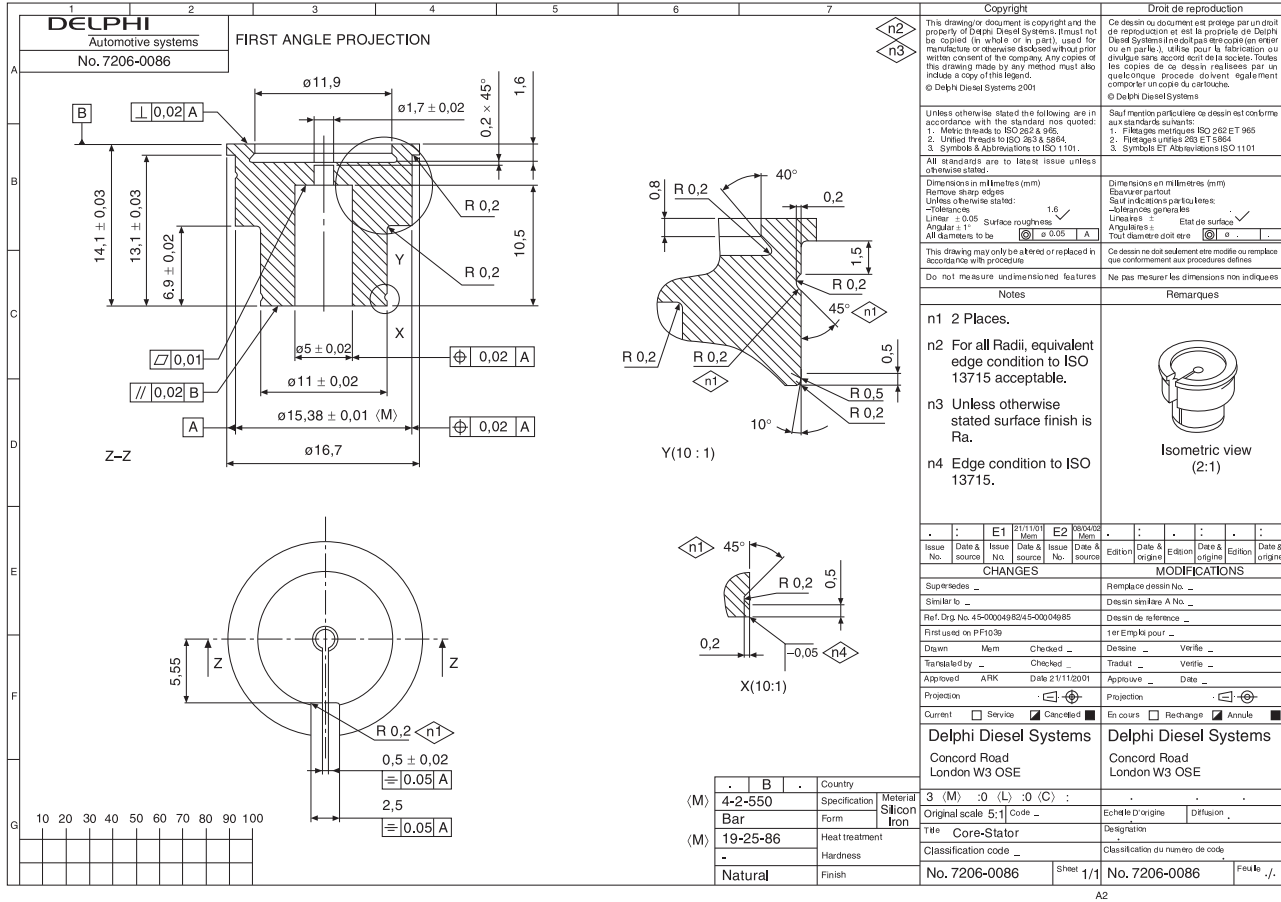


Fig. 38.5 Example of supplemental documentation on a drawing sheet.

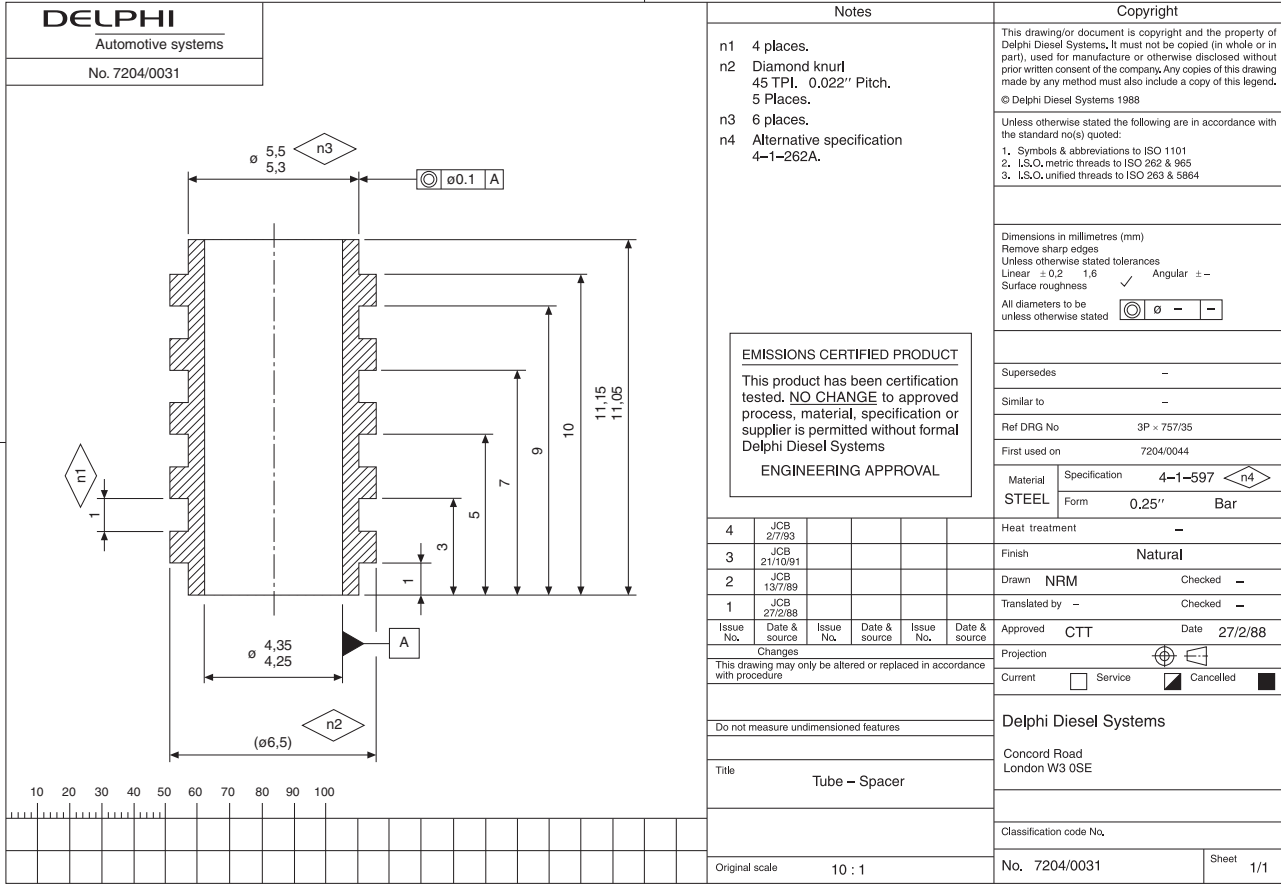


Fig. 38.6 Example of supplemental documentation on a drawing sheet.

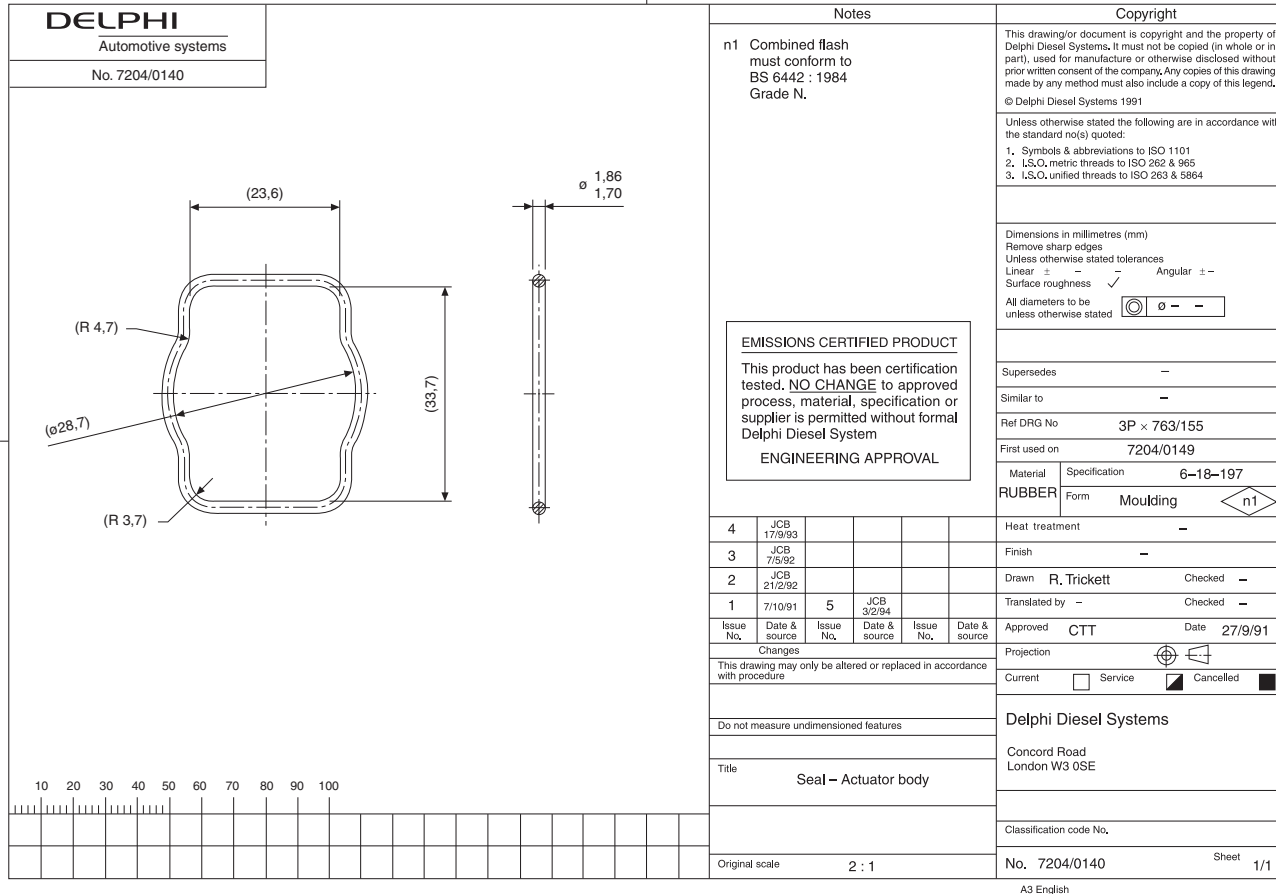


Fig. 38.7 Example of supplemental documentation on a drawing sheet.

Designers producing manual drawings have always derived much personal satisfaction from producing drawings in ink or pencil where the linework and lettering is uniform and neat, and where the illustration completely defines the requirements of the specification. A similar degree of satisfaction can be obtained by producing drawings on CAD equipment. Particular care with the spacings of center lines, contrasts in linework, cross hatchings, positioning of dimensions, notes, etc., are all small details in their own way, but they collectively contribute to quality, balance and overall clarity. Check the reason for the position of each and every line; ensure that it conforms with the appropriate standard and that it conveys a clear and unambiguous meaning to the reader. Engineering drawings can be considered to be works of art. We both hope you will produce many.

## Further standards for design, project and risk management of interest to engineers and manufacturers

### *Design management*

The first priority of an organization is to ensure that it survives and prospers. A business that fails to continuously develop its product range is unlikely to grow in real terms, especially with the increase in open competition across the globe.

This major series of management standards helps organizations plan ahead for products and services into the future thus ensuring continuity of revenue streams.

The BS 7000 series – Design Management Systems, is divided into concise parts applicable to different sectors.

BS 7000-1	Guide to managing innovation
BS 7000-2	Guide to managing the design of manufactured products
BS 7000-3	Guide to managing service design
BS 7000-4	Guide to managing design in construction
BS 7000-6	Guide to managing inclusive design
BS 7000-10	Glossary of terms used in design management
BS EN 62402	Obsolescence management. Application guide.

### *Project management*

BS 6079-1 Guide to Project Management, describes a full range of project management procedures, techniques and tools that you can select as appropriate to your project. It gives guidance on the planning and execution of projects and the application of project management techniques. The standard has a broad relevance to projects in

many industries including the public sector, both at home and abroad. The principles and procedures outlined are relevant to all sizes of organization.

This standard aims primarily to provide guidance for relative newcomers to project management and to act as an aide-memoire for more experienced practitioners and those who interact with project management teams.

The other parts of BS 6079 are also available:

BS 6079-2:2000 Project Management – Vocabulary

BS 6079-3:2000 Project Management – Guide to the Management of Business Related Project Risk Project Management.

These three standards can be purchased as kit 3.

BS 6079 part 4 is published as a PD 6079-4 Project Management in the Construction Industry BS IEC 62198. Project Risk Management Application Guidelines: this standard provides an internationally approved process for managing project and project-related risks in a systematic and consistent way. It is relevant to decision-makers, including project managers, risk managers and business managers.

BS IEC 62198 provides a general introduction to project risk management and its sub-processes and influencing factors, such as:

- establishing the context, including confirmation of project objectives;
- risk identification;
- risk assessment, including risk analysis and evaluation;
- risk treatment, impact mitigation and probability reduction;
- review and monitoring;
- communication (including consultation);
- learning from the project.

Guidelines are also provided on the organizational requirements for implementing the process of risk management appropriate to the various phases of a project.

Details regarding content and current prices can be obtained from BSI Customer Services, 389 Chiswick High Road. London W4 4AL website: [www.bsi-global.com/bsonline](http://www.bsi-global.com/bsonline). Tel.: +44 20 8996 9001. E-mail: [orders@bsi-global.com](mailto:orders@bsi-global.com).

Additive manufacture also known as 3D printing, formally known as rapid prototyping is a process whereby parts can be produced from 3D model by adding material, presently either plastic or metal, layer upon layer to produce a part or parts.

Additive manufacturing has been continually developed through the 80's,90's and 00's and has come a long way since the early days when it was commonly known as rapid prototyping. In these days the main output from this technology was look alike, touchy-feely prototypes/replicas of simple concept designs with the main purpose being the reduction of the time scale of the concept/optionsing phases of design thus reducing the time to manufacture/market.

The process of building parts layer upon layer has not changed greatly since the early days but development in materials in terms of type, ease of use and mechanical properties has made additive manufacturing a real credible option to machining from solid, casting and fabrication. AM can also be used to produce parts that cannot be produced conventionally i.e. parts with internal features or parts with complex geometry.

Today the technology is widely available for use in the home to aerospace applications.

As well as prototyping, additive manufacturing is ideally suited to high complexity, low volume components. Designs and subsequent modifications can be quickly realised into functioning components without the expense of tooling. For high volume components alternative manufacturing methods should be investigated.

## General design considerations

- Type of AM process – does it best suit the performance criteria of the product including available materials.
- Build area/volume – will the part fit and in which orientation will it be built. It may be worth considering producing large parts in two or more parts and joining them.
- Weight/material reduction – on conventionally (subtractive) manufactured parts surplus material often remains as it adds cost to remove it or in some cases most of the base material is removed to produce the part. With AM, only the material necessary for the function of the part needs to be manufactured, see Fig. 39.4.
- Reduction of parts – some AM processes can produce an assembly of parts such as a Ball Bearing or a Nut on a Bolt. Careful consideration on the accuracy and resolution of the AM process is required to produce the clearances necessary for the function of the part.
- Post build processing such as machining to a close tolerance or to produce a finer surface texture is possible if machining allowances are included. Including fixturing/holding features may aid postprocessing.
- Wall thicknesses can influence the stability of the part, thin walls (say <1.5 mm) may need permanent supports (ribs). Thick walls (say >12 mm) may impact thermal stability, if so, using a lattice structure for the internal part of a wall or a hollow wall may suit. As a guide

recommended thickness to height ratios are shown in [Table 39.1](#) for ratios outside of these it is recommended to produce test pieces to confirm suitability.

- Test pieces – if the mechanical properties of the AM part are important then test pieces should be manufactured at the same time as the part build. Test piece orientation should represent the load condition, builds in the X, Y & Z directions and also ZX and ZY may be possible depending on the process. Note: If the part includes a lattice structure in the load path the test piece should be representative and include a lattice.

To produce an AM part a 3D model is processed (usually in to a.STL file) which produces sectional slices which are then ‘printed’ layer upon layer until the part is complete.

## AM processes

Selective Lasering Sintering (SLS) and Direct Metal Laser Sintering (DMLS) – is a powder based fusion process where a thin layer of powder (usually 0.1 mm thick) is fused using a laser. The bed of the machine lowers to allow another layer of material to be spread on top of the fused material and the process repeats until the part is complete, see [Fig. 39.1](#). One benefit this process has is that the unfused material acts as a support so that additional supports are not required (see FDM). Hollow parts can be produced if a small hole is incorporated to aid removal of the unfused powder. The unfused powder can also be retained within the part if there is no impact on function, if this is the case, care must be taken to ensure that any escaped trapped powder does not impair performance when in use. Typical materials are Nylon, Glass or Carbon filled Nylon, Polypropylene, Polyurethane and some metals such as Aluminum, Titanium and Stainless Steel. The build volume is approximately  $800 \times 400 \times 600$  mm. Other processes of this type are Selective Heat Sintering, Selective Laser Melting, Direct Metal Laser Sintering and Electron Beam Melting.

Fused Deposition Modeling (FDM) – this process uses thermoplastic material in cord form which is stored in a cassette which is deposited through a heated nozzle. The nozzle traces the section/slice of the part on to the bed of the machine which then lowers to allow the next layer of material to be deposited, see [Fig. 39.2](#). This process allows for lightweight honeycombed parts where the external skin of a part can be produced with varying degrees of fill as required. Depending on build orientation, parts with overhangs may need to have supports (not unlike scaffolding) to complete the part. These supports are made from a different material which can either be broken off or dissolved away in a caustic bath supplied with the machine. The build volume is approximately  $900 \times 600 \times 900$  mm. In general this process is not as accurate as the other systems due to nozzle size but what it lacks in accuracy it more than makes up in versatility and range of stable materials such as Nylon, ABS and Polycarbonate.

Stereolithography (SLA) – this is a Vat Polymerisation process where parts are built in UV curing epoxy resin materials. The part is built on a platform which incrementally lowers into the vat where a layer of resin representing the sectional slice is cured by UV light, see [Fig. 39.1](#). The platform, the process repeats until the part is completed. Like the FDM process some parts may require support structures and may require additional curing to ensure stability. Like the SLS process hollow structures can be produced if the facility to drain the uncured resin is included in the part. The build volume can be up to  $1500 \times 750 \times 500$  mm.

Jetting – the simplest way to describe this process is to think 3D Ink Jet printing. The build material, usually acrylic resins, is jetted from the print head onto the build platform which lowers to allow additional layers to be deposited, see Fig. 39.2. The build volume can be as much as  $1000 \times 800 \times 500$  mm. Supports are generally required unless walls are built in the Z direction. Part builds are not limited to one material so flexible and rigid parts can be combined.

3D Printing or Binder Jetting (3DP) – this process is again similar to Ink Jet Printing. A layer of powder, usually starch based, is swept over the build platform and the jet head deposits a binding material to ‘print’ the cross-sectional layer. The build platform lowers, another layer of material is applied, and binding material ‘printed’, see Fig. 39.2. This is repeated until the part is built. Like SLS this process does not require supports because the un-printed material provides this function and hollow parts can be produced.

Directed Energy Deposition (DED) – this is a metal manufacturing process where the build material in either wire or powder form is melted by either a Laser, Plasma Arc or Electron Beam and deposited onto a substrate rather than a build platform. As the other processes the layers are built up to complete the part. Build materials can be but not limited to Stainless Steel, Titanium, Inconel and Aluminum Alloys. This process is well suited to repairing/reconditioning damaged parts by adding material to worn areas which can then be finished machined. Near Net parts can also be produced to reduce costly material removal to produce the final part. Build volume can be in excess of  $1500 \times 1000 \times 1000$  mm. DED machines can also be connected with CNC machine to carry out the post processing finished machining.

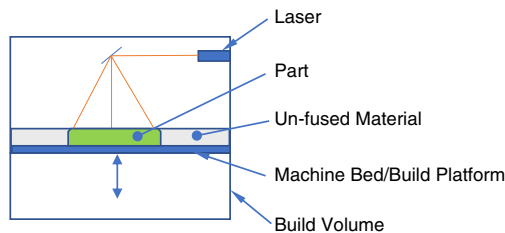


Fig. 39.1 Basic AM powder/vat machine.

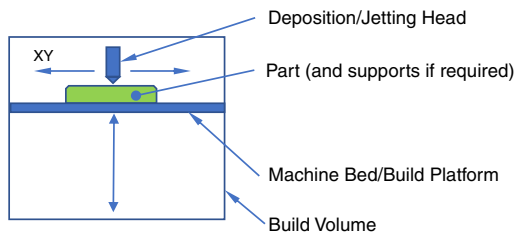


Fig. 39.2 Basic AM deposition/jetting machine.

## Design/build recommendations

The following recommendations are purposely generic, where there are differences between the AM processes these are noted, it is highly recommended to liaise with AM provider on capability and capacities.

Material optimisation/weight saving software is available and should be considered. Designers should understand the function and interfaces of the part once this is known the non-functional aspects can be removed see Fig. 39.4 as a basic example where non-functional material has been removed.

Where possible self-supporting parts should be built as this eliminates the need for additional supports however, unused material in the powder processes can act as supports see Fig. 39.3C for a simple example.

See Table 39.1 for process specific recommendations, as noted above it is highly recommended to consult with the AM provider on build capabilities.

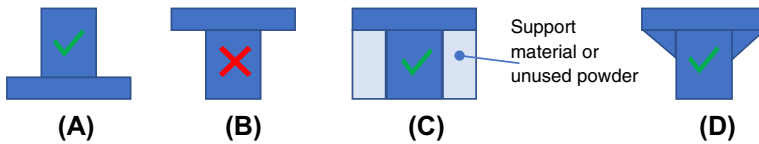


Fig. 39.3 Overhangs/supports.

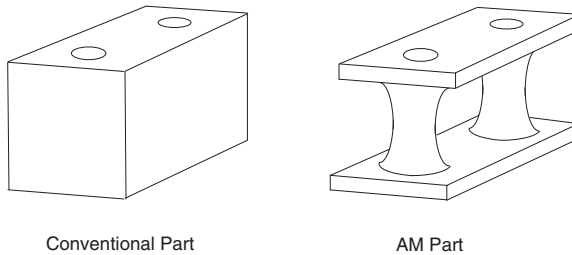


Fig. 39.4 Basic example of function/weight saving.

## Materials

To ensure product quality it is essential that the quality control of the raw material is tightly managed. Cross contamination of materials or materials stored outside of recommended limits could have a damaging effect on product performance.

## Drawings

Even today with the range of CAD/CAM products enabling design and manufacturing to be completed without the need for drawings, drawings are still produced as either the prime manufacturing/contract document, as supplemental information to 3D models or as a long-term record of the design. Parts manufactured by AM are no different and the choice as to how much information is shown on the drawing is a matter for company, contractual or legislative requirements, but where possible, there is a great opportunity to reduce the information on the drawing down to the essentials, say specific features, features to be post processed or reference dimensions.

In both cases it is important to understand the build accuracies/uncertainties of the process and decide if the condition of 'as built' features are acceptable straight off the machine without further processing. If so, then it may be possible to add a reference

dimension(s) which can be given a cursory check to confirm the part is as it should be. Or, where specific features or post processing is required then these features can be specified as they would conventionally. To allow for repeatability should further parts be manufactured, it is essential that the configuration status of the model the part was made from, the type of AM process and materials used to make the part are fully specified on the drawing.

## Suitability for AM

The following limiting factors can be used as a check to see if AM is suitable for the designed product:

- Size (will it fit in the AM machine, multi-parts?)
- Material (is the design material suitable for AM)
- Quantity (low or high volume)
- Strength (is the AM material strong enough)
- Environment when used (is the AM material suitable)
- Post processing (how much)

## Related standards

The following standards relating to AM may be of use to the designer.

ISO 17,296-2 Additive manufacturing –General principles –Part 2: Overview of process categories and feedstock.

ISO 17,296-3 Additive manufacturing –General principles –Part 3: Main characteristics and corresponding test methods.

ISO 17,296-4 Additive manufacturing –General principles –Part 4: Overview of data processing.

ISO/ASTM 52,900:2 Additive manufacturing –General principles –Terminology.

ISO/ASTM DIS 52,901.2 Additive manufacturing –General principles –Requirements for purchased AM parts.

ISO/ASTM NP 52,902 •Additive manufacturing –General principles –Standard test artifacts.

ISO/ASTM DIS 52,903-1 Additive manufacturing –Standard specification for material extrusion based additive manufacturing of plastic materials –Part 1: Feedstock materials.

ISO/ASTM CD 52,903-2 Additive manufacturing –Standard specification for material extrusion based additive manufacturing of plastic materials –Part 2: Process –Equipment.

ISO/ASTM NP 52,905 Additive manufacturing –General principles –Non-destructive testing of additive manufactured products.

ISO/ASTM DIS 52,910.2 Guidelines for additive manufacturing design.

ISO/NP TR 52,912 Design of functionally graded additive manufactured parts.

ISO/ASTM 52,915:2016 Specification for additive manufacturing file format (AMF) Version.

ISO/ASTM 52,921:2013 Standard terminology for additive manufacturing –Coordinate systems and test methodologies.

**Table 39.1** AM build characteristics features/processes.

Feature	AM process					DED
	SLS/DMLS	FDM	SLA	3DP	Jetting	
Holes	Build with the axis in the Z direction gives better roundness and surface texture than the XY direction Through holes should be considered in preference to blind holes (post processing can be carried out in both cases). Post processing can be used to increase accuracy					As this process is presently the least accurate with poor surface texture it is usually used for repairing parts or near net builds with subsequent post process machining. Sizes of constituent elements of the parts i.e. holes and walls are dependent on the correct machining allowances being allocated.
	<1 mm diameter are not recommended. Recommended depth/diameter ratio is 8:1 however a 12:1 ratio may be achieved for holes above 3 mm diameter.	<1 mm diameter are not recommended. Holes above 6 mm diameter, built in the X or Y direction, may need supports.	<1 mm diameter are not recommended. Recommended depth/diameter ratio is 10:1 however a ratio of 20:1 may be achieved for holes above 3 mm diameter.	<2 mm diameter are not recommended. Holes above 3 mm diameter recommended depth/diameter ratio is 5:1.	<1 mm diameter are not recommended. Recommended depth/diameter ratio is 10:1	
Edges	Avoid sharp edges use radii where possible					
Walls	Thickness < 1 mm is not advised. Recommended max unsupported height/width ratio 25:1, above this supports should be considered.	Thickness < 1 mm is not advised. At 1 mm thick permanent supports should be considered. Consider hollow or lattice core walls.	Thickness < 1 mm is not advised. Recommended max unsupported height/width ratio 27:1, above this supports should be considered.	Thickness < 1 mm is not advised. Recommended max unsupported height/width ratio 40:1, above this supports should be considered.	Thickness < 1 mm is not advised. Recommended max unsupported height/width ratio 20:1, above this supports should be considered.	It is recommended that the AM provider is consulted early in the design process to establish what is possible.
	Consider hollow or lattice cored walls					

<p>Overhangs (not in the downward orientation (see Fig. 39.3A)</p>	<p>Are possible due to the supporting unused material (see Fig. 39.3C). Angular buttress/bracket type supports are recommended for flange like overhangs (see Fig. 39.3D).</p>	<p>Use of breakaway or soluble supports are recommended. Overhangs 2 mm thick up to 15 mm and bridges 3 mm thick up to 75 mm can be built, dimensions above this can be achieved but is material dependant.</p>	<p>Angular buttress/bracket type supports are recommended for flange like overhangs (see Fig. 39.3D).</p>	<p>Are possible due to the supporting unused material. &lt;1.5 mm thick is not recommended. Ledge length/thickness ratio 12:1 and bridge length/thickness ratio 25:1 are recommended.</p>	<p>Not recommended unless supports are used. The length of a bridge is limited to the strength of the build material.</p>
<p>Clearance between parts</p>	<p>Generally, aim for 0.5 mm, clearances down to 0.2 mm can be achieved but test pieces should be produced to confirm functionality.</p>	<p>&lt;0.5 mm in the Z direction is not recommended. Avoid clearances in the XY direction.</p>	<p>Dependent on the laser spot size. Clearances should be produced in the Z direction. 0.5 mm can be achieved but is limited by depth of clearance (up to 6 mm), the larger the clearance the greater the depth, as a guide a ratio of 40:1 can be used. Test pieces should be produced to confirm functionality.</p>	<p>Generally, not recommended due to the unpredictable properties of the bonding material. &gt;2 mm in the Z direction can be achieved but trials are recommended.</p>	<p>&lt;1.5 mm in the Z direction is not recommended</p>
<p>Threads.</p>	<p>Best results are achieved when built in the Z direction, holes can be thread cut or finished conventionally. Threads in plastic materials are prone to wear.</p>	<p>Not advisable but can be post processed</p>	<p>Not advisable but can be post processed</p>	<p>Not advisable but can be post processed</p>	<p>Not advisable but can be post processed</p>
<p>Consider the use of wire thread inserts for female threads</p>					

Continued

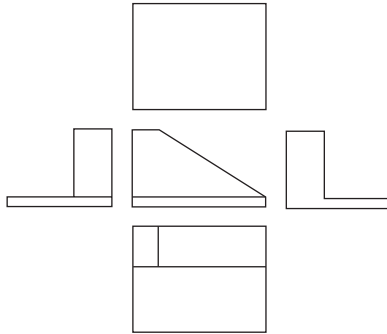
**Table 39.1** AM build characteristics features/processes.—cont'd

Feature	AM process					
	SLS/DMLS	FDM	SLA	3DP	Jetting	DED
Removal of unused material	<p>Removal from lattice structures may be difficult.</p> <p>Careful positioning of drainage openings may be required, these should be as large and as numerous as possible.</p> <p>Internal cavities should be designed to evacuate by gravity and have features akin to an egg timer to aid draining.</p> <p>Post processing operations to create and /or close openings can be performed.</p> <p>Removal of all unused material from blind holes or cavities can be difficult.</p>	Not applicable	<p>Avoid trapped uncured material.</p> <p>Careful positioning of drainage openings may be required, these should be as large and as numerous as possible.</p> <p>Internal cavities should be designed to evacuate by gravity and have features akin to an egg timer to aid draining.</p> <p>Post processing operations to create and /or close openings can be performed. Pressurised air or spinning to centrifugally remove material is possible but the fragility of the part should be considered.</p> <p>Removal of all unfused material from blind holes or cavities can be difficult.</p>	<p>Removal from lattice structures may be difficult.</p> <p>Careful positioning of drainage openings may be required, these should be as large and as numerous as possible.</p> <p>Internal cavities should be designed to evacuate by gravity and have features akin to an egg timer to aid draining.</p> <p>Post processing operations to create and /or close openings can be performed.</p> <p>Removal of all unused material from blind holes or cavities can be difficult.</p>	<p>Removal from lattice structures will be difficult.</p>	

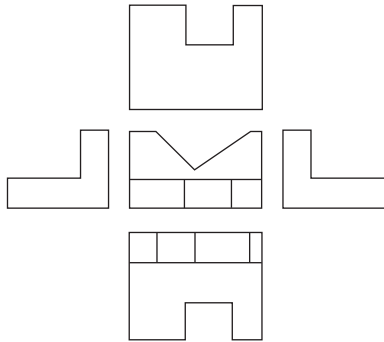
Weight reduction	<p>Consider hollow sections and the use of lattice structures.</p> <p>Consider building only the functional elements of the part (see Fig. 39.4)</p> <p>Removal of unused material must be considered</p>	<p>Consider hollow sections, the use of lattice structures or less dense support material.</p> <p>Consider building only the functional elements of the part (see Fig. 39.4)</p>	<p>Consider hollow sections and the use of lattice structures built in the Z direction</p> <p>Consider building only the functional elements of the part (see Fig. 39.4)</p> <p>Removal of unused material must be considered</p>	<p>Consider hollow sections, the use of lattice structures or less dense support material.</p> <p>Consider building only the functional elements of the part (see Fig. 39.4)</p>	<p>Consider hollow sections, the use of lattice structures. Removal from lattice structures will be difficult</p>
Removal of part from build platform	<p>Metal powder – heat soak platform and part to relieve stresses.</p> <p>EDM, Milling, Sawing. If the EDM process is used for removal of part, unused material may cause a short circuit.</p>	<p>Breakoff or soluble base layer</p> <p>Flexible build platform</p>	<p>Cut with blade/spatula</p> <p>Flexible build platform</p>	<p>Cut with blade/spatula</p> <p>Flexible build platform</p>	<p>Cut with blade/spatula</p> <p>Flexible build platform</p>
Process specific issues to be considered	<p>Metal powder - reducing supports may reduce effects of thermal stress, as will adding radii at the interface with the build platform which can be machined off post process.</p> <p>Flexible plastic parts can be built but are material dependant.</p>	<p>Build quality is dependent on extruding head size.</p> <p>Surface texture can be improved by post processing.</p>	<p>Removal of trapped uncured material, see above.</p>	<p>The robustness of the finished part should be considered.</p>	<p>Consideration on the design of the intersection/joint between flexible and rigid parts.</p>

# Drawing solutions

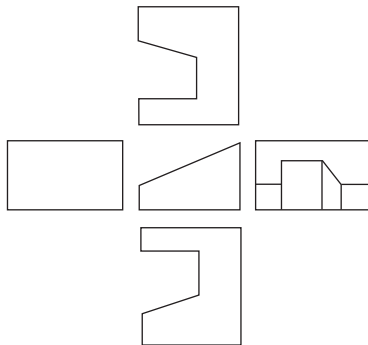
## 1. Solutions to Fig. 6.17



(A)

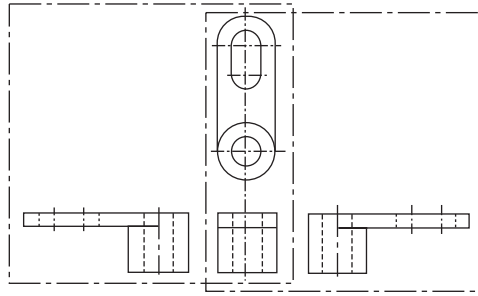


(B)

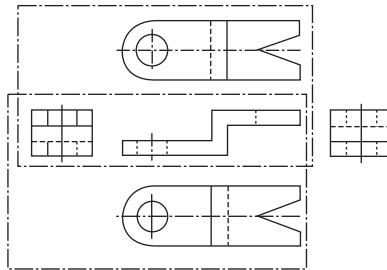


(C)

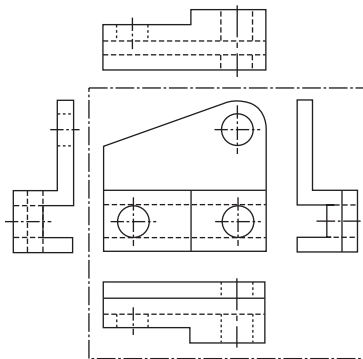
2. Solutions to Fig. 6.18



(A)

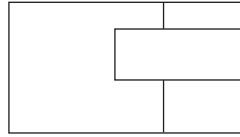
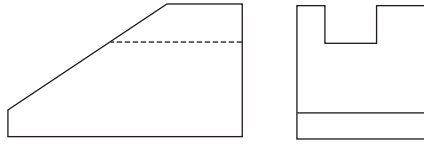


(B)

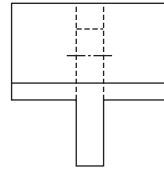
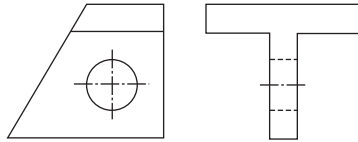


(C)

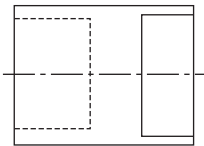
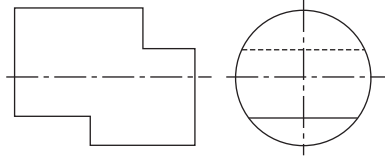
3. Solutions to Fig. 6.19



(A)

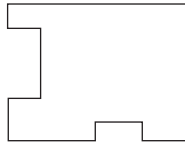
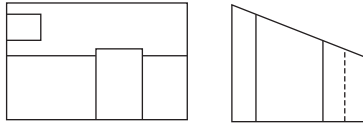


(B)

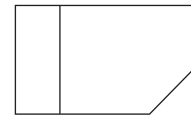
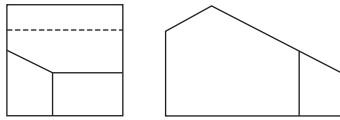


(C)

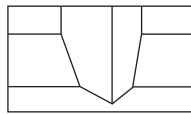
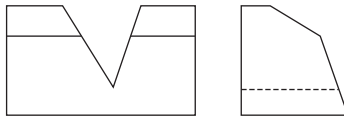
## 4. Solutions to Fig. 6.20



(A)

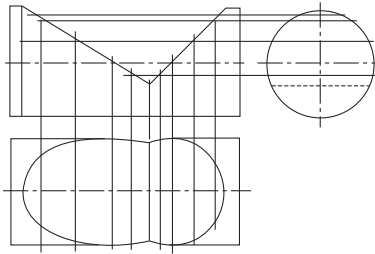


(B)

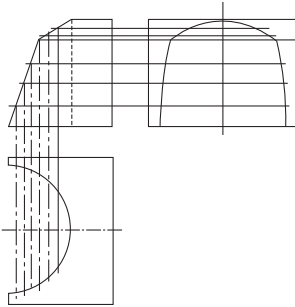


(C)

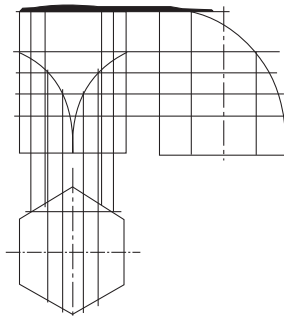
5. Solutions to Fig. 6.22



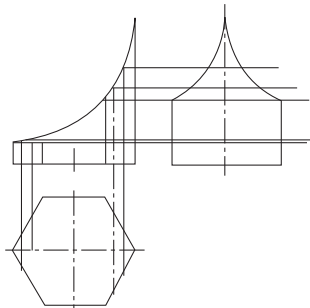
(A)



(B)

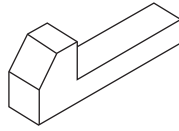


(C)

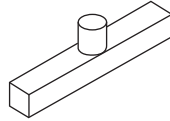


(D)

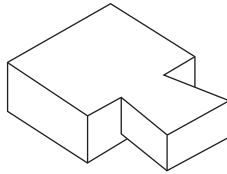
## 6. Solutions to Fig. 6.23



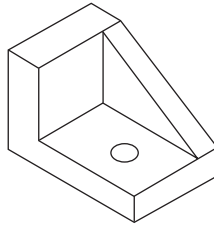
(A)



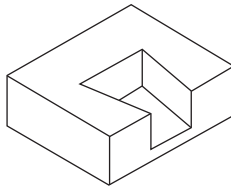
(B)



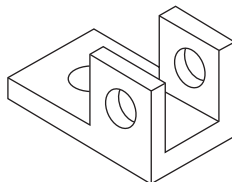
(C)



(D)

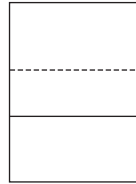
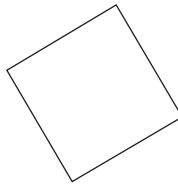
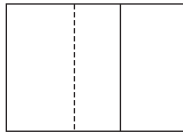


(E)

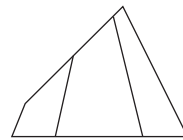
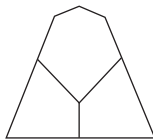
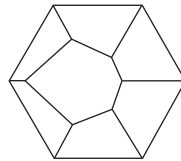


(F)

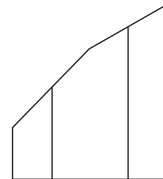
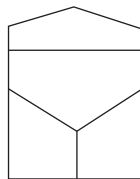
7. Solutions to Fig. 6.24



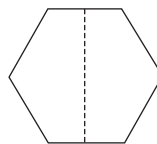
(A)



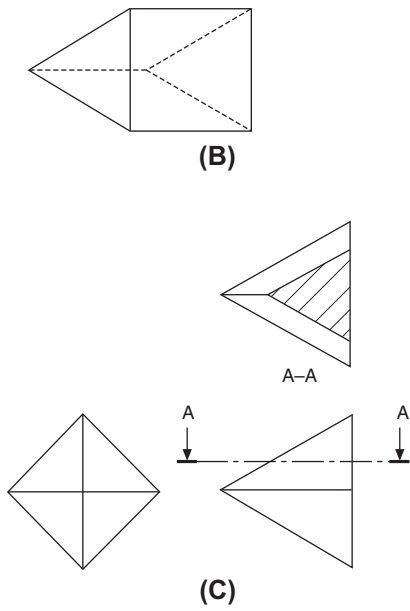
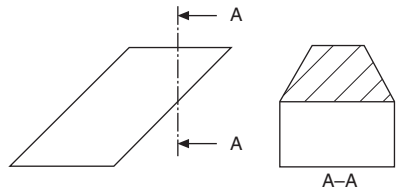
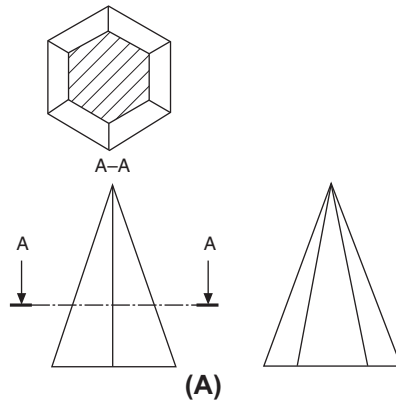
(B)



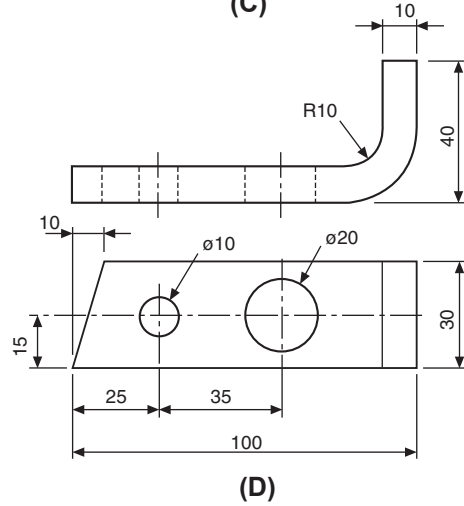
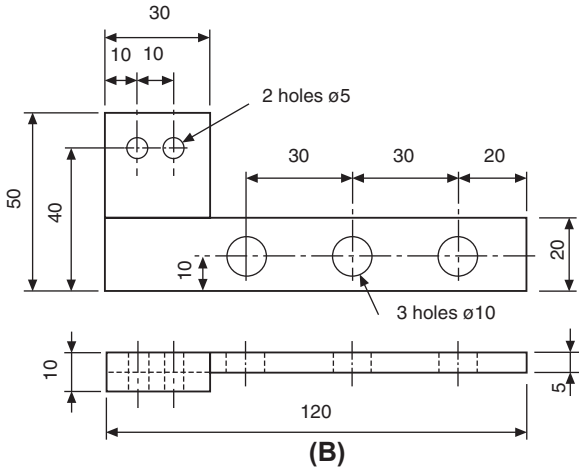
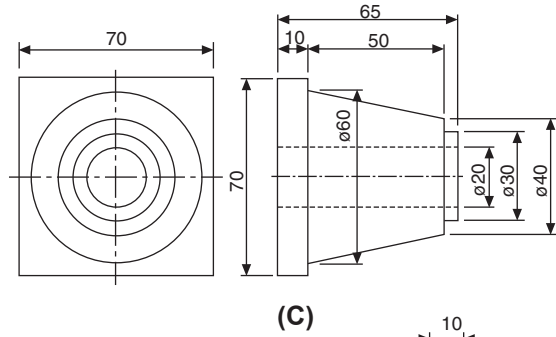
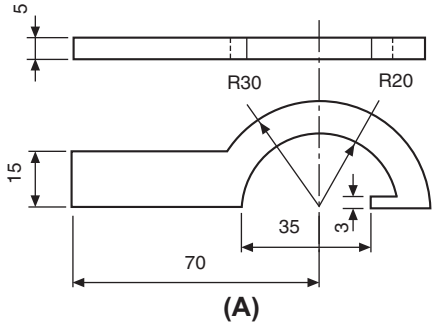
(C)



8. Solutions to Fig. 6.25



9. Solutions to Fig. 6.26



# Index

*Note:* ‘Page numbers followed by “f” indicate figures and “t” indicate tables’.

## A

- Abbreviations, 106–108
- Acme thread, 214
- Acrylic adhesives, 552
- Addendum, 433
  - angle, 439
- Additive manufacture (AM), 1, 16, 44, 395, 585
  - deposition/jetting machine, 587f
  - design considerations, 585–586
  - design/build recommendations, 587–588
  - materials, 588–589
  - powder/vat machine, 587f
  - processes, 586–587
  - related standards, 589
  - suitability, 589
- Adhesives, 547
  - acrylic, 552
  - bond line, 548–549
  - bonded joints, 549–552, 550f
  - bonding, 547
  - designing for, 547–548
  - engineering applications, 553–557
  - high shear-strength, 556f
  - hot melt, 552
  - instant, 557–559, 558f
  - locking by, 247
  - mild steel stiffeners, 560f
  - production applications, 559f
  - solvent based contact, 552
  - structural applications, 559–560
- Adobe Acrobat files, 8
- Air engine, 264, 267f
  - assembly, 274, 276f
  - solutions in third angle projection, 278f
- Aligned dimension, 191
- Alloy steels, 445
- AM. *See* Additive manufacture (AM)
- American Standard AWS A2.4, 462
- American thread, 212
- Anaerobic adhesives, 552
- Anaerobic principle, 554
- AND function (logic), 502
- Angular contact ball bearings, 531, 531f
- Angular dimensions, 191
- Angular distance, curves dimension using, 189–200
- Angular misalignment, 527
- Angularity, 333–335
- Animated 3D presentations, 1
- Anodizing, 386–387
- Antimony, 521–522
- Applications Manager, 8–9
- Araldite, 247
- Arc
  - bisection, 120, 120f
  - center of, 120, 120f
- Arc length, curves dimension using, 189–200
- Arc welding, 461
- Archimedean spiral, 136, 137f
- ASME Y 14.5M and ISO/BS 8888 standards
  - comparison, 411, 411t–416t
  - applicability of standards, 411
  - datums specification, 416–417
  - exclusion of surface texture, 417
  - symbolology, 416
  - tolerancing principle, 417–418
- ASME Y14.41 standards (technical product documentation), 395
- Assembly, 23
- Assembly drawings, 94–96, 94f
- Association and Duality Principle, 408
- Atmospheric corrosion, 389
- Austenitic stainless steels, 446
- AutoCAD, 36
- Auxiliary dimension, 184–186

- Auxiliary views, 147
  - first and second auxiliary projection, 149f
  - from front elevation, 150f
  - isometric view of rectangular block, 147f
  - orthographic views in first angle projection of rectangular block, 148f
- Available space for ball and roller bearings, 526
- Axial displacement in ball and roller bearings, 528
- Axial location of bearings, 537
- Axis feature in 3D annotation, 397–398
- B**
- BA thread. *See* British Association thread (BA thread)
- Backup of CAD, 19
- Ball and roller bearings
  - angular contact ball bearings, 531, 531f
  - application, 534–535, 535f
  - axial displacement, 528
  - axial location of bearings, 537
  - bearing suitability for particular applications, 529f
  - with cylindrical bore, 535–537
  - cylindrical roller bearings, 531, 532f
  - deep groove ball bearings, 530, 530f
  - fits and tolerances, 537
  - general convention, 545
  - grease lubrication, 543
  - location methods, 538, 539f
  - mounting and dismounting, 528
  - needle roller bearings, 532, 532f
  - oil lubrication, 544
  - precision, 527
  - rigidity, 528
  - sealed and shielded bearings, 542–543
  - seals, 538–541
  - selection, 526–527
    - angular misalignment, 527
    - available space, 526
    - bearing loads, 526–527
    - limiting speeds, 527
  - self-aligning ball bearings, 531, 531f
  - simplified representation, 545, 545f
  - spherical roller bearings, 532, 533f
  - spherical roller thrust bearings, 534, 534f
  - taper roller bearings, 533, 533f
  - with tapered bore, 537
  - thrust ball bearings, 533, 533f
  - trouble-free bearing operation, 545
- Barrier coatings, 383
- Base circle, 433
- Bases of fits (hole and shaft), 285–286
- Bearings
  - angular contact ball, 531, 531f
  - application, 534–535, 535f
  - axial location of, 537
  - ball and roller, 526–545
  - with cylindrical bore, 535–537
  - cylindrical roller, 531, 532f
  - deep groove ball, 530, 530f
  - fits and tolerances, 537
  - loads, 526–527
  - materials, 522
  - needle roller, 532, 532f
  - plain, 519–526
    - direct-lined housings, 519–520
    - insert liners, 520–521
    - lubrication, 521
    - materials, 521
    - whitemetals, 521–522
  - prelubricated, 523f
  - sealed and shielded, 542–543
  - seals, 538–541
  - selection, 526–527
  - self-aligning ball, 531, 531f
  - spherical roller, 532, 533f
  - spherical roller thrust, 534, 534f
  - structural, 525f, 526
  - suitability for particular applications, 529f
  - taper roller, 533, 533f
  - with tapered bore, 537
  - thick walled, 524f
  - thrust ball, 533, 533f
- Beryllium copper, 446
- Bevel gears, 439–442, 440f
- Bilateral limits, 284, 285f, 297
- Bimetallic corrosion, 390–391
- Binder jetting, 587
- Bisection
  - angle, 119, 119f
  - arc, 120, 120f
  - straight line, 119, 120f
- Block diagrams for engineering diagrams, 472
- Bolts, 221f
  - dimensions, 222t
  - drawing, 223

- Bond line for adhesives, 548–549
- Bonded joints using adhesives, 547–552, 550f
- Bonded stiffeners, 549, 551f
- Boxed dimensions, 294
- Brass springs, 446
- British Association thread (BA thread), 213
- British Standard Fine thread (BSF thread), 212
- British Standard Pipe thread (BSP thread), 212
- British Standard Whitworth thread (BSW thread), 212
- British Standards, 1–2
- BS 21 (pipe threads), 212
  - BS 308 (withdrawal), 9
  - BS 499–1, 468
  - BS 1553 (graphical engineering), 509–518
  - BS 1553 (graphical symbols), 471
  - BS 1574 (ferrous and non-ferrous split cotter pins), 246–247
  - BS 1580 (unified threads), 211
  - BS 2917 (fluid power systems), 471
  - BS 3643 (hexagon bolts screws and nuts), 221, 224–225
  - BS 3643–2 (ISO metric threads), 208, 211
  - BS 4235 (key dimensions), 251
  - BS 4500 (limits and fits), 281, 286
  - BS 4827 (ISO miniature screw threads), 213
  - BS 5070 (diagram drawing practice), 6
  - BS 7000 series, 583
  - BS 8887 family of Standards, 27
  - BS 8887, 23
  - BS 8887–1, 23–25
  - BS 8887–2, 26
  - BS 8887–3, 26
  - BS 8887–240, 27
  - BS 8888 (dimensioning), 182
  - BS 8888 (drawing paper), 71
  - BS 8888 (drawing standards), 2, 6, 9
    - basic differences, 11–12
    - TPD and specification, 11–12
  - BS 8888 (replacement of BS 308), 9–11
  - BS EN 20286 (ISO system of limits and fits), 286
  - BS EN ISO (CAD technical information), 19
  - BS EN ISO 1302 (metrology), 379
  - BS EN ISO 1580 (machine screw nuts), 229, 240
  - BS EN ISO 2553, 462
  - BS EN ISO 2692 (MMC/LMC), 291, 363
  - BS EN ISO 4762 (socket head screws manufacture), 224–225
  - BS EN ISO 5456–3 (pictorial representations), 89
  - BS EN ISO 5458 (positional tolerances), 365
  - BS EN ISO 6410–1, 208
  - BS EN ISO 7045 (machine screw nuts), 229, 240
    - construction drawing, 471
    - limits and fits, 283–284
- British Standards Institution (BSI), 23, 26–27, 561–562
- British Standards Online, 563
  - CD-ROM, 563
  - DISC, 563
  - foreign standards and translations, 562
  - knowledge center, 562
  - Perinorm, 562
  - PLUS, 562
  - standards-making process, 563–564
  - technical information group, 562
- British Standards Online, 563
- British Standards Publishing Ltd, 563
- BSF thread. *See* British Standard Fine thread (BSF thread)
- BSI. *See* British Standards Institution (BSI)
- BSP thread. *See* British Standard Pipe thread (BSP thread)
- BSW thread. *See* British Standard Whitworth thread (BSW thread)
- Building management building system, 484–486, 485f
- Bushed bearing bracket, 259, 260f, 268–269, 271f
- Butt weld, 463t–464t, 465–466
- Buttress thread, 214
- ## C
- CAD. *See* Computer aided design (CAD)
- CAI. *See* Computer Aided Inspection (CAI)
- Cam, 421
  - dimension, 431
  - example, 424–431
  - followers, 421
  - motions, 422–424
  - operated clamp, 261–264, 262f, 273f, 274

- CAM. *See* Computer aided machining (CAM); Computer Aided Manufacture (CAM)
- Camshaft, 425
- Candidate datums, 417
- Capital letters, character height for, 77–78
- Cascade system, 506–507, 506f
- Cascade valve, 507
- Castle nuts, 239, 240f
- CD-ROM, 563
- Center distance, 433
- Certificate of ownership, 32
- Certification, ISO, 567
- Chain
  - dimension, 184–186
  - lines, 74–77
- Chamfers dimension, 195
- Character height of capitals, 77–78
- Characteristics
  - evaluation, 2, 12
  - specification, 2, 12
- Chemical corrosion, 389
- Chord length, curves dimension using, 189–200
- Chrome vanadium steel square drive socket wrench, 45, 45f
- Chromic acid process, 386–387
- Chromium–vanadium steel, 445
- Circle
  - circumscription around triangle, 121, 121f
  - dimension, 188
  - inscription in triangle, 121, 121f
- Circuit diagrams for engineering
  - diagrams, 472
  - construction diagrams, 475
  - theoretical circuit diagrams, 474–475
- Circular pitch, 433
- Circular run-out, 335–338
- Circularity (roundness), 319–321
- Circumscription Circle around triangle, 121, 121f
- Clearance, 433
  - drill, 219
  - fit, 281, 281f
- Cleavage, 547–548, 548f
- Coaxiality, 344–346, 356–357, 360
- Codes of practice, 3
- Coil springs, 240, 445
- Coinciding lines, 77
- Collection and Duality Principle, 409, 409f
- Collective assembly drawing, 95, 95f
- Collective single-part drawings, 93, 93f
- Collision detection, 45
- Combined seals for bearings, 542
- Common datum, 303, 307–311
- Communicating design concepts, 43–45
  - mockups and prototypes, 43–44
  - production, 44
  - rendering controls, 44–45
- Communication developments, 36–37
- Company communications, 3
- Company standards, 3
- Completed drawings, 575
- Components
  - drawings, 2
  - not drawn in section, 115
- Compression, 547–548, 548f
  - springs, 446–448, 449f
- Computer
  - models, 16
  - purchase, 37
  - size of, 39
- Computer aided design (CAD), 7–9, 13–15, 35, 72, 119, 259, 575
  - access into computer network, 20
  - directory tree for controlled access to database, 21f
  - draughting, 16–18
  - equipment, 37
  - organization and applications, 35
    - communicating design concepts, 43–45
    - computer and software purchase, 37
    - materials options, 45–47
    - parametric design, 39–41
    - pipework systems, 42–43
    - project development, 37–39
    - sheet metalwork application, 41–42
    - size of computer, 39
  - product development, 19
  - QA, 21
    - steps in design and development, 13, 14f
    - technical product documentation, 18–20
- Computer Aided Inspection (CAI), 8, 37, 395
- Computer aided machining (CAM), 8
- Computer Aided Manufacture (CAM), 17, 37, 395
- Concentricity, 344–346

## Cones

- ellipses, 133–134, 133f
- Interpenetration of solids, 160–166
- parabolas, 155–157
- rectangular hyperbolas, 157–159

## Configuration control, 8

## Conformity assessment, 566–567

## Conic sections, 156f

- intersection of cylinder passing through cone, 164f
- parabola construction, 155–157
- rectangular hyperbola construction, 157–159

## Conical helix, 138–140

## Construction, 409f

- diagrams, 475
- Duality Principle, 409
- involute, 432, 432f
- nuts, 223–224

## Controller output temperature, 483

## Copper-base alloys, 446

## Copyright, 32

## Correctly formed patent application, 30

## Corrosion of metals, 388–393

- bimetallic, 390–391
- crevice, 392
- design considerations to minimizing effects of, 393
- dezincification, 393
- even or uniform corrosion, 389
- fretting, 392–393
- galvanic, 390–391
- pitting, 392, 392f
- stress, 392
- weld decay, 393

## Corrosion prevention, 460

## Counterbores dimension, 196–197

## Countersunk holes dimension, 199

## Countersunk screws, 248

## Crevice corrosion, 392

## Cross-hatching, 109, 111f

## Curves dimension, 127–129, 128f, 189

- using arc length, chord length or angular distance, 189–200

## Cutting planes, 109, 110f

## Cyanoacrylate adhesives, 552

## Cycloid, 140, 140f

## Cylindrical cam, 421

## Cylindrical roller bearings, 528, 531, 532f

## Cylindricity, 321

**D**

## Danish Standards Association, 11

## Data

- management, 402
- sheets, 4

## Database Right, 32

## Datum targets, 303, 311

- indication, 311
- practical application, 311
- symbols, 311

## Datums, 303, 365

- methods of specifying datum features, 305–306
- specification, 416–417
- system, 303, 306–307

DED. *See* Directed Energy Deposition (DED)

## Dedendum, 433

- angle, 441

## Deep groove ball bearings, 530, 530f

## Delivering Information Solutions to Customers (DISC), 563

## Design certificates, 31

## Design for Inspection, 11

## Design for Manufacture, 11

## Design for manufacture, assembly, disassembly and end-of-life processing (MADE), 23, 25

## Design for manufacture to end of life, 23, 24f

## 'Design Intent Measurand', 2, 12

## Design layout drawings, 96

## Design management, 583

## Design office management and organization, 2, 4–5, 5f

- BS 8888, 11–12

## drawing practice and computer, 7–9

## drawing standard, 9–10

## engineering drawing practices, 6

## general computer policy relationships, 7f

## replacement of BS 308, 10–11

## revisions, 10

## sources of information, 4f

## structure, 9f

## Designs, 30–32

## patents, 31

## registered design rights, 31

## rights, 30

## unregistered design rights, 31–32

## Desktop publishing, 16

- Dezincification, 393  
 Diagonal scales, 105  
 Diagram, 6  
 Diameters dimension, 189  
 Diametral pitch, 433  
 Dimension(s), 181
  - aligned, 191
  - angular, 191
  - auxiliary, 184–186
  - cams, 431
  - chain, 184–186
  - chamfers, 195
  - circles, 188
  - counterbores, 196–197
  - countersunk holes, 199
  - curves, 189–200
    - using arc length, chord length or angular distance, 189–200
  - developed parts, 201
  - diameters, 189
  - edges, 203–205
  - features not drawn to scale, 184
  - flats, 196
  - holes, 196
  - keyways, 256–258
  - manufacture, 205
  - non-rigid parts, 312–313
  - parallel, 186
  - property indicators, 184–189
  - radii, 188
  - restricted areas, 201–202
  - running, 186
  - spherical radii, 189
  - spotfaces, 199–200
  - squares, 196
  - staggered, 187
  - tapers, 193–194
  - thin parts, 200–201
  - two mating tapers, 194–195
  - unidirectional, 191
    - use of between symbol, 202–203
- Dimensioning of welds, 468–469, 469  
 Direct Metal Laser Sintering (DMLS), 586  
 Direct-lined housings, 519–520  
 Directed Energy Deposition (DED), 587  
 Direction of tolerance zones, 401  
 DISC. *See* Delivering Information Solutions to Customers (DISC)  
 Disc springs, 455, 458f
- Dismounting in ball and roller bearings, 528  
 Displacement diagram, 146, 146f  
 Disposal, 25–26  
 Division of lines, 104  
 DMLS. *See* Direct Metal Laser Sintering (DMLS)  
 Documentation, 17  
 Double-headed feather key, 253, 254f  
 Draughting
  - conventions associated with threads, 215–217
  - standards, 3
- Drawing layouts and simplified methods
  - assembly drawings, 94–95, 94f
  - collective assembly drawing, 95
  - collective single-part drawings, 93, 93f
  - combined detail and assembly drawings, 96
  - design layout drawings, 96
  - exploded assembly drawings, 97–98
  - machine drawings, 100–102
  - simplified drawings, 98
  - single-part drawing, 91–92
- Drawing(s), 1–2, 6, 37, 588–589
  - air engine, 264, 267f
  - bolts, 223
  - bushed bearing bracket, 259, 260f
  - cam operated clamp, 261–264, 262f
  - drill table, 259–261, 261f
  - engineering drawing practices, 6
  - geometrical tolerances, 298
  - modifications, 79
  - nuts, 223
  - plug cock, 264, 265f
  - practice and computer, 7–9
  - procedure, 56
  - scales, 103–104
  - solutions, 109
  - standard, 9–10
  - toolbox, 264–267, 269f
  - welding symbols on, 462–468
- Drill
  - clearance, 219
  - table, 259–261, 261f, 269, 272f
  - tapping, 219
- Drum cam, 421  
 Duality Principle, 406, 406f
  - advantages, 410
  - design specification and verification, 405–409, 405f

**E**

Edges dimension, 203–205  
Electrochemical corrosion, 389  
Electrodeposited coatings, 385  
Electroless nickel process, 386  
Electronics  
    pneumatics and, 507–518  
    symbols in, 510t–518t  
Electroplating, 385  
Elevation, 168, 170, 172–173, 176, 259  
    and plan view, 575, 578f  
Ellipse construction, 131–134  
Energy, 519  
    engineering diagrams in energy-saving applications, 489–493  
Engineering  
    adhesives. *See* Adhesives  
    departments, 4  
    design, 29  
Engineering diagrams  
    block diagrams, 472  
    building management, 484–486  
    circuit diagrams, 472  
    controller output temperature, 483  
    energy-saving applications, 489–493  
    engineered systems, 472–475  
    graphical symbols, 471–472  
    heating, ventilation and air conditioning systems, 476–489  
    humidity control, 483–484  
    pneumatics  
        and electronics, 507–518  
        systems, 495–507  
    refrigeration systems, 489–493  
    safety devices, 483–484  
    symbols, 473t–474t  
    temperature control, 482–484  
Engineering Drawing Office Practice Standard, 1–2  
Engineering drawings, 3  
    practices, 6  
Envelope requirement, 289, 290f  
Epicycloid, 140–141, 141f  
Epoxy, 552  
European Committee for Electrotechnical Standardization (CENELEC), 471–472  
European projection, 54

European Standards Authority, 11  
Even or uniform corrosion, 389  
Exploded assembly drawings, 97–98  
Extraction and duality principle, 408, 408f

**F**

Face angle, 439  
Face cam, 421  
Fatigue in springs, 460  
FDM. *See* Fused deposition modeling (FDM)  
FEA. *See* Finite element analysis (FEA)  
Feather key, 252–253, 255f  
Features-of-size in geometrical tolerancing, 418  
Fillet, 434  
    weld, 461, 468–469  
Filtering, 408  
Filtration and duality principle, 405–406  
Finite element analysis (FEA), 8, 16–17, 395  
First angle projection, 2, 49  
    arrangement, 51f–52f  
    cut away block, 50f  
    dimensioning, 70  
    with dimensions, 54f  
    orthographic, 63  
    pictorial view, 50f  
    plotted curves, 63, 66f  
    symbols, 55f  
First auxiliary elevation, 147  
Fits, 279  
    in ball and roller bearings, 537  
    clearance, 281, 281f  
    hole basis, 286–289, 287t–288t  
    interference, 281, 282f  
    transition, 281, 282f  
Fixtures, 17  
Flat springs, 449–450, 449f–450f  
Flatness, 318–319  
Flats dimension, 196  
Flow charts, 42, 474  
Follower of cams, 421  
    motions, 422–424  
Foreign standards and translations, 562  
Form and limits of size, 279  
Fretting corrosion, 392–393, 535–536  
Friction, 519

- Front elevations, 54  
 Fuel injector for diesel engine, 46f, 47  
 Fused deposition modeling (FDM), 44, 586  
 Fusion welding, 461
- G**
- Galvanic corrosion, 390–391  
 Gas welding, 461  
 Gaskets and adhesives, 554  
 Gears  
   bevel, 439–442, 440f  
   conventions, 434f  
   helical, 437–438  
   involute gear teeth proportions and relationships, 434  
   Professor Unwin’s construction for, 435–437  
   ratio, 433  
   spur, 432–434  
   worm gearing, 443–444  
 Geometric solids third angle projection, 67, 68f  
 Geometrical constructions  
   bisection angle, 119, 119f  
   bisection arc, 120, 120f  
   bisection straight line, 119, 120f  
   circumscribe circle around triangle, 121, 121f  
   finding center of arc, 120, 120f  
   hexagon constructions  
     for distance across flats, 122  
     for given distance across corners, 121–122  
   inscribe circle in triangle, 121, 121f  
   regular octagon constructions  
     for distance across flats, 123  
     for given distance across corners, 123  
   regular polygon constructions, 124  
 Geometrical product specification (GPS), 395  
 Geometrical tolerances and datums, 293, 297  
   advantages, 293–294  
   angularity, 333–335  
   applications, 293  
   circular run-out, 335–338  
   circularity (roundness), 319–321  
   coaxiality, 344–346  
   concentricity, 344–346  
   cylindricity, 321  
   datums, 303  
   drawings, 298  
   flatness, 318–319  
   general rules, 294  
   parallelism, 325–329  
   perpendicularity (squareness), 329–333  
   position, 339–343  
   profile tolerance of line, 322–325  
   profile tolerance of surface, 325  
   straightness, 315–317  
   symmetry, 346–347  
   TEDs, 294  
   total run-out, 338–339  
 GGB Bearing Technologies, 526  
 Gib head key, 252, 254f  
 GL. *See* Ground line (GL)  
 Glacier Metal Company Limited, 522  
 GPS. *See* Geometrical product specification (GPS)  
 Graphical symbols, 377  
   complete, 376  
   composition, 377  
   engineering diagrams, 471–472  
   expanded, 375  
   surface texture, 375  
 Grease lubrication of bearings, 543  
 Ground line (GL), 53
- H**
- Half sections, 111, 112f  
 Hard copy original drawings, care and storage of, 79  
 Hardware, 35  
 Hatching  
   lines, 109  
   of two adjacent parts, 111f  
 Heat  
   of evaporation, 490  
   recovery control in refrigeration systems, 491  
 Heating, ventilation and air conditioning systems, 476–489  
 Helical extension springs, 452–454, 453f  
 Helical gears, 437–438, 438f  
 Helix angle, 138  
 Hexagon constructions  
   for distance across flats, 122  
   for given distance across corners, 121–122  
 Hexagonal prism development, 168, 169f  
 High shear-strength adhesives, 556f

- High temperature hot water (HTHW), 476
- High-nickel alloys springs, 446
- Hole(s)
- basis, 286–289, 287t–288t
  - dimension, 196
  - projection exercises, 60, 62f
- Horizontal plane (HP), 53, 53f
- Hot dipped coatings, 383–384
- Hot melt adhesives, 552
- HP. *See* Horizontal plane (HP)
- HTHW. *See* High temperature hot water (HTHW)
- Humidity control, 483–484
- Hypocycloids, 141–146
- I**
- ICS. *See* International Classification for Standards (ICS)
- IEC. *See* International Electrotechnical Commission (IEC)
- Inconel (high-nickel alloy), 446
- Industrial Revolution manufacturers, 2
- Inscription in triangle (circles), 121, 121f
- Insert liners for bearings, 520–521
- Instant adhesives, 552, 557–559, 558f
- Intellectual property (IP), 29
- Intellectual Property Office (IPO), 29, 31
- Interchangeable systems for limits and fits, 283–284, 283f
- Interference fits, 281, 282f
- International Classification for Standards (ICS), 567
- International Electrotechnical Commission (IEC), 471–472, 561, 564
- International Federation of National Standardizing Associations (ISA), 564
- International Organization for Standardization (ISO), 211, 293, 561, 564
- 272 (hexagon bolts screws and nuts), 221
  - 1101 (geometrical product specification), 395
  - 2553, 462
  - 8015, 418
  - 16792 (technical product documentation), 395
- catalog, 567–573
- certification, 567
- conformity assessment, 566–567
- Envelope Principle, 417–418
- member countries, 568–573
- metric threads, 208–211
- thread sizes, 209t–210t
- quantity and quality, 565–566
- standards
- ISO 272 standard, 221
  - metric hexagon socket button head screws, 225, 226t, 227f
  - metric hexagon socket cap screws, 225, 226t
  - metric hexagon socket countersunk head screws, 227, 228f
  - metric hexagon socket set screws, 227, 228f, 229t
  - metric hexagon socket shoulder screws, 225, 226t
- International Patent Application, 30
- Interpenetration
- curve, 170, 171f
  - of solids, 160–166
    - of cone and square prism, 164f
    - elliptical intersections, 160
    - of offset inclined differing diameters, 162f
- Involute, 135–136
- construction, 135–136, 135f, 432, 432f
  - gear teeth proportions and relationships, 434
- IP. *See* Intellectual property (IP)
- IPO. *See* Intellectual Property Office (IPO)
- Irregular curves, 189–191
- ISA. *See* International Federation of National Standardizing Associations (ISA)
- ISO. *See* International Organization for Standardization (ISO)
- ISO/BS 8888 and ASME Y 14.5M standards comparison, 411, 411t–416t
- ISO/TC 213 committee, 11
- Isometric
- projection, 81–85, 84f
  - scale, 81, 82f
- J**
- Jetting, 587
- Jigs, 17

**K**

- Keys, 251
  - examples and function, 251f
  - sunk, 252–254
  - taper, 253f
  - woodruff, 255
- Keyway, 251
  - dimension, 256–258
  - edge-milled, 252f
  - end-milled, 252f
  - in hub, 252f
  - taper, 253f
- Knife-edge followers, 421
- ‘Knock on effect’, 60

**L**

- Labyrinths, 541
- Ladder diagram, 509, 509f
- Landscape presentation, 72
- Layers, 17–18
- Layout, 60
- Leaf springs, 452
- Least material condition (LMC), 284, 294, 352
- Lettering, 77
- Life cycle, 23
- Limiting speeds in ball and roller bearings, 527
- Limits, 279, 294, 297
  - interpretations, 289–291
  - size and form, 279
  - unilateral and bilateral, 284
- Lined inserts for bearings, 520
- Lines, 72–74, 73t–74t
  - of action, 433
  - CAD, 72
  - chain, 74–77
  - coinciding, 77
  - division of lines, 104
  - drawing paper sizes, 71
  - presentation, 72
- Liquid-honing, 460
- LMC. *See* Least material condition (LMC)
- Loads for ball and roller bearings, 526–527
- Local sections, 115
- Loci
  - Archimedean spiral, 136
  - cycloid, 139f, 140

- ellipse construction, 131–134
- epicycloid, 140–141
- hypocycloid, 141–146
- involute, 135–136
- right-hand conical helix, 138–140, 139f
- right-hand cylindrical helix, 136–138, 137f

**Locking**

- by adhesives, 247
- devices, 238
- plates, 243
- screw threads, 553, 553f
- terminals, 245f
- washer, 242f
- wire, 241–243

Loctite adhesive, 247

Locus, 131

Logic functions, 501–503

Low temperature hot water (LTHW), 476

Lubricants, 519

Lubrication of bearings

- oil, 544
- plain bearings, 521

**M**

- Machine drawings, 100–102, 103f
  - layouts, 100–102
  - worked examples in, 259
- Machine screws, 229
  - nuts, 231
  - standards, 223
- Machining operations, 18
- MADE. *See* Design for manufacture, assembly, disassembly and end-of-life processing (MADE)
- Manufacturing
  - dimensions, 229
  - units, 5
- Martensitic stainless steels, 446
- Mating constraints, 45
- Maximum material condition (MMC), 284, 294, 351, 417–418
  - coaxiality, 356–357
  - geometrical form, 352–353
  - perfect form, 358–360
  - position, 355–356
  - squareness, 354, 359–360
  - straightness, 353
  - two mating components, 362–363

- Measured value, 2, 12  
Mechanical springs, 445  
Median feature in 3D annotation, 397–398  
Medium-walled insert liners, 520  
MEMORY function (logic), 502, 503f  
Metal coatings, 383  
    anodizing, 386–387  
    electrodeposited coatings, 385  
    electroless nickel process, 386  
    hot dipped, 383–384  
    painting, 388  
    powder, 388  
    sheradized coating, 386  
    sprayed metal, 384  
    vacuum deposited, 387  
Metal inert gas (MIG), 461  
Microfilmed successive lines, 109  
MIG. *See* Metal inert gas (MIG)  
Minimum character height for capital letters  
    and numerals, 77–78, 78t  
Missing lines projection exercises, 63, 64f  
Missing views projection exercises, 63, 65f  
Mitre gears, 439  
MMC. *See* Maximum material condition  
    (MMC)  
Mockups, 43–44  
Modifications, CAD, 37  
Module, 433  
Mounting in ball and roller bearings, 528  
Multi-layers in CAD, 37  
Multimedia applications, 16  
Multiple threads, 217–218
- N**
- Needle roller bearings, 532, 532f  
Network, 20  
Nimonic 90 (high-nickel alloy), 446  
Nominal dimension, 295  
Nominal model and duality principle,  
    407, 407f  
Non-rigid parts dimensions, 312–313  
Non-rubbing seals bearings, 540–541, 540f  
NOT function (logic), 502, 502f  
Numerals, minimum character height for,  
    77–78  
Numerical analysis, 16–17  
Nuts, 221, 221f  
    castle, 239  
    construction, 223–224  
    dimensions, 222t  
    drawing, 223  
    machine screws, 229, 231  
    nut-and-bolt fastening, 95, 95f  
    slotted, 239  
    wing, 237
- O**
- Oblique cones, 173  
Oblique projection, 85–89, 88f  
Octagons construction, 123  
Oil lubrication, 544  
    oil bath lubrication, 544, 544f  
    oil jet lubrication, 544, 544f  
Oil-tempered wire, 445  
Opposed signals, 506  
OR function (logic), 502, 502f  
Orientation geometrical tolerances, 347–350  
Orthographic views, pictorial sketching  
    from, 63  
Outside diameter, 441
- P**
- Paintings, 1, 388  
Paper sizes for drawings, 71  
Paperless manufacture, 395  
Parabola construction, 155–157  
Parabolic motion, 423  
Parallel dimension, 186  
Parallel keys, 256–258  
Parallel pins, 243–246, 246f  
Parallelism, 325–329  
Parametric design in CAD, 39–41  
Partition and duality principle, 407, 408f  
Patent Office, The, 29  
Patents, 29–30  
Path of contact, 433  
Patterns from sheet materials  
    cylindrical transition piece development,  
        176f  
    examples of finishing edges, seams and  
        corners, 167f  
    four part elbow joint development, 170f  
    interpenetration curve, 171f  
    oblique cone development, 174f  
    open box development, 168f  
    partial hexagonal pyramid development,  
        173f  
    partial oblique cone development, 175f

- Patterns from sheet materials (*Continued*)  
 partial square pyramid development, 172f  
 partial triangle prism development, 177f  
 radial line development, 171f  
 rectangular transition piece development, 178f  
 square to circular transition piece development, 179f–180f  
 thin lamina development, 170f
- PD. *See* Personal directory (PD)
- Peel, 547–548, 548f
- Peening, 248
- Peg feather key, 254, 254f
- Perfect form in MMC, 358–360
- Perinorm database, 562
- Perpendicularity (squareness), 329–333
- Personal directory (PD), 20
- Phosphor bronze springs, 446
- Photo-realistic effects, 45
- Piano wire, 445
- Pictorial sketching from orthographic views, 63
- Pipe threads, 212
- Pipework systems, 42–43
- Pitch  
 angle, 439  
 pitch-circle diameters, 433  
 point, 433
- Pitting corrosion, 392, 392f
- Plain bearings  
 direct-lined housings, 519–520  
 insert liners, 520–521  
 lubrication, 521  
 materials, 521  
 whitemetals, 521–522
- Plain scales, 105–106
- Plain-carbon steels, 445
- Planes, 53
- Plans, 54, 259
- Plate cams, 421, 422f
- PLCs. *See* Programmable logic controllers (PLCs)
- PLM. *See* Product lifecycle Management (PLM)
- Plotted curves, 63
- Plug cock  
 assembly, 274, 275f  
 drawings, 264, 265f
- PLUS. *See* Private list updating service (PLUS)
- Pneumatic systems, 495–507  
 air line installation, 497f  
 circuit design, 496–501  
 compressor installation, 495f  
 logic functions, 501–503  
 pneumatics and electronics, 507–518  
 sequential circuits, 504–507  
 symbols, 498t–499t  
 symbols in, 510t–518t
- Point of tangency, 125
- Polygon constructions, 124
- Polytetrafluoroethylene (PTFE), 526
- Portrait presentation, 72
- ‘Posidriv’ Machine Screws, 229
- Position  
 complementary requirements in surface texture, 377–380  
 geometrical tolerances, 300, 339–343  
 MMC, 355–356
- Positional tolerancing, 294, 307, 365  
 product requirement, 366–373  
 TED, 365–366  
 zone, 366
- Post welding heat treatment, 461–462
- Powder coating, 388
- Power transmission, threads for, 213–214
- Practical demonstrations, 37
- Precision in ball and roller bearings, 527
- Pressure angle, 433
- Principle of independency, 289, 290f
- Printed circuit boards, 17
- Prism  
 hexagonal prism, 168, 169f  
 triangular, 176
- Private list updating service (PLUS), 562
- Product lifecycle Management (PLM), 8
- Production, 44  
 tooling, 17
- Production drawings, 575  
 CAD system, 575  
 design management, 583  
 manual drawings, 583  
 project management, 583–584  
 supplemental documentation, 579f–582f
- Productivity, 36
- Professor Unwin’s construction for gears, 435–437

Profile tolerance  
  of line, 322–325  
  of surface, 325

Programmable logic controllers (PLCs), 508

Programmable sequence controllers, 508, 508f

Project development and CAD, 37–39

Project management, 583–584

Projection exercises, 60–70  
  missing lines, 63, 64f  
  missing views, 63, 65f  
  pictorial sketching from orthographic views, 63  
  plotted curves, 63, 66f  
  radii and holes, 60, 62f  
  straight line, 60, 61f

Projection symbols, 54  
  first angle symbol projection, 55f  
  proportions, 55f  
  third angle symbol projection, 56f

Property indicators, 184–189

Prototypes, 43–44

Provisional layout drawings, 96

Psychrometric chart, 486–489, 487f–488f

PTFE. *See* Polytetrafluoroethylene (PTFE)

Pulley, 575, 576f

## Q

Quality assurance (QA), 21

Quantity production, 2

## R

RA. *See* Room air (RA)

Radial line development, 170–172, 171f

Radii  
  dimension, 188  
  and holes projection exercises, 60, 62f

Radius tangent to straight lines, 129–130

Rapid machining, 16

Rapid prototyping. *See* Additive manufacture (AM)

Reading engineering drawings, 57–60

Reconditioning, 26–27

Rectangular hyperbola construction, 157–159, 158f

Rectangular key, 252

Recycling, 25–26

Refrigerant cycle, 490, 491f

Refrigeration engineering diagrams, 489–493  
  control options, 492–493  
  condensate control connections, 493f  
  heat recovery using two condensers, 492f  
  indoor swimming pool/ice rink, 494f  
  refrigeration cycle of shopping complex, 495f  
  heat recovery control in refrigeration systems, 491  
  refrigeration through evaporation, 490

Registered design rights, 30–31

Registered trademark, 32

Regular octagon constructions  
  for distance across flats, 123  
  for given distance across corners, 123

Related standards, 561

Remanufacture, 26

Remarketed products, 27

Remarks position and tolerance, 300

Removed sections, 113, 114f

Rendering controls, 44–45

Repurpose, 26

Requirements for drawings, 21

Resistance welding, 461

Retaining applications  
  adhesives, 554, 554f  
  devices, 238

Retardation motion and cam follower, 423, 423f

Retrieval of drawings, 6

Reuse, 26

Reusing, 25

Revolved sections, 111–113, 113f

Reworking, 25

Right-hand conical helix, 138–140, 139f

Right-hand cylindrical helix, 136–138, 137f

Rigidity in ball and roller bearings, 528

Roller follower, 421

Room air (RA), 476

Root diameter, 433

Root-cone angle, 439

Rubbing seals, 541–542, 542f

Running dimension, 186

## S

Saddle keys, 255, 256f

Safety devices, 483–484

Sales departments, 4, 16

- Sand-cast bracket, 92
- Scales
- diagonal, 105
  - drawing, 103–104
  - geometric construction, 104–106, 104f–105f
  - plain, 105–106
- Schematics, 474
- Screen sizes, 35
- Screw
- countersunk head, 227, 228f
  - external form to illustrate thread terms, 208f
  - left and right handed threads, 207f
  - ‘Posidriv’, 229
  - socket head, 224–225
  - thread-cutting, 248–250
  - threads, 207, 216
  - unified system of, 211
- Screwcutting, 216
- Sealed and shielded bearings, 542–543
- Sealing with anaerobic gaskets, 554–555, 555f
- Seals, 538–541
- combined, 542
  - lubricated seals, 543f
  - non-rubbing, 540–541, 540f
  - rubbing, 541–542, 542f
- Sectional views in third angle projection, 67, 69f
- Sections, 109
- components not drawn in, 115
  - conic, 156f
  - half, 111, 112f
  - local, 115
  - removed, 113, 114f
  - revolved, 111–113, 113f
  - successive, 115
  - thin material, 114, 114f
  - two parallel planes, 115, 117
  - views, 109
- Selective Laser Sintering method, 44
- Selective Lasering Sintering (SLS), 586
- Self-aligning ball bearings, 531, 531f
- Sellers thread, 212
- Semi-automatic circuit, 503, 504f
- Sequence diagrams, 474
- Service/maintenance, 4
- Services drawings, 42
- Shaft, 575, 577f
- Shakeproof thread-cutting screws, 248–249
- Shakeproof washers, 240
- Shear, 547–548, 548f
- Sheet metalwork application and CAD, 41–42
- Shellac adhesive, 247
- Sheradized coating, 386
- Shot-peening, 460
- Side or end elevations, 54
- Silicon–manganese steel, 445
- Simmonds locknut, 239–240, 240f
- Simple harmonic motion, 423, 424f
- Simplified drawings, 98
- Single datum, 303, 306f
- Single-part drawing, 91–92
- Single-start square thread, 138
- Sketches, 1
- Skin model, 407, 407f
- SLA. *See* Stereolithography (SLA)
- Slotted joints, 549, 551f
- Slotted nuts, 239, 240f
- SLS. *See* Selective Lasering Sintering (SLS)
- Socket head screws manufacture, 224–225
- Software, 35, 43
- Software purchase, 37
- Solid modeling, 37, 395
- Solid-insert liners, 520
- Solids Interpenetration, 160–166
- Solvent based contact adhesives, 552
- Spherical radii dimension, 189
- Spherical roller bearings, 532, 533f
- Spherical roller thrust bearings, 534, 534f
- Split cotter pins, 246–247, 247f
- dimensions, 248t
- ‘Spot’ welding, 461
- Spotfaces dimension, 199–200
- Sprayed metal coatings, 384
- Springs
- alloy steels, 445
  - compression, 446–448, 449f
  - copper-base alloys, 446
  - corrosion prevention, 460
  - disc, 455
  - fatigue conditions, 460
  - flat, 449–450, 449f
  - helical extension, 452–454, 453f
  - high-nickel alloys, 446
  - leaf, 452
  - plain-carbon steels, 445

- specifications, 455–459
  - stainless steels, 446
  - steel sealing washers, 542
  - torsion, 451–452
  - washers, 240, 241f
  - wire forms, 460
  - Spur gears, 432–434
  - Square key, 252
  - Square thread, 213–214, 214f
  - Squareness and MMC, 354, 359–360
  - Squares dimension, 196
  - Staggered dimensions, 187
  - Stainless steels, 446
  - Standardized protocols, 566
  - Standards, 2–3, 561
    - BSI, 561–562
    - for costs, 4
    - for dimensioning, 3
    - ISO, 564
  - Standards-making process, 563–564
  - Stationary load, 535
  - Steels
    - alloy, 445
    - plain-carbon, 445
    - stainless, 446
  - Stereolithography (SLA), 44, 586
  - Storage of drawings, 79
  - Straight line intersection, 158f, 161
  - Straight line projection exercises, 60, 61f
  - Straightness, 315–317
  - Stress
    - calculations, 16–17
    - corrosion, 392
  - Structural applications
    - adhesives, 559–560, 560f
    - bearings, 525f, 526
    - design, 16–17
  - Sub-assembly drawing, 94
  - Successive sections, 115
  - Sulfuric acid process, 386–387
  - Sunk keys, 252–254
  - Superglues, 552
  - Surface coatings, 383
  - Surface Finish, 383–388
  - Surface texture, 383
    - complete graphical symbols, 376
    - expanded graphical symbols, 375
    - geometrical tolerancing standards comparison, 417
    - graphical symbols, 375, 377
    - positions for complementary requirements, 377–380
    - roughness, 378
  - Symbology, 416, 416f
  - Symbols
    - graphical, 471–472
    - welding, 462–468, 463t–464t
  - Symmetry, 346–347
  - Systems Manager, 8–9
- T**
- Tab washers, 243, 244f
  - Tangency, 125
    - curve between two external circles, 127–128
    - curve between two internal circles, 128–129, 128f
    - to ellipse, 133, 134f–135f
    - external tangent to circles, 126, 126f
    - internal and external tangents of equal diameter, 127, 127f
    - internal tangent to circles, 126, 127f
    - radius
      - joining straight line and circle, 129, 129f
      - tangent to straight lines, 129–130
    - tangent to circle from any given point
      - outside circle, 125
    - tangent to point on circumference of circle, 125
  - Tangent, 125
  - Taper(s), 193
    - dimensioning, 194
    - key and keyway, 253f
    - pins, 243–246, 246f–247f
    - roller bearings, 533, 533f
  - Tapping drill, 219
  - Taylor principle, 289, 417–418
  - Technical information group, 562
  - Technical product documentation (TPD), 11, 18–20, 25
  - TEDs. *See* Theoretically exact dimensions (TEDs)
  - Temperature control diagrams, 482–484
  - Template, 167, 223
  - Tension, 547–548, 548f
  - Theoretical circuit diagrams, 474–475
  - Theoretically exact dimensions (TEDs), 102, 193, 293–294, 365–366

- Thermally conductive material, 461–462
- Thick-walled bearings, 520
- Thicknesses of line, 72, 75f
- Thin material sections, 114, 114f
- Thin-walled insert liners, 520–521
- Third angle projection, 49–54  
 arrangement, 51f–52f  
 geometric solids, 67, 68f  
 sectional views in, 67, 69f  
 symbols, 56f
- Third party, 566–567
- Thread sealing pipe fittings, 553, 553f
- Thread-cutting screws, 248–250
- Threads  
 acme, 214  
 British Association, 213  
 buttress, 214  
 conventions application, 218  
 draughting conventions associated with, 215–217  
 multiple, 217–218  
 power transmission, 213–214  
 screw, 207  
 square, 213–214, 214f  
 unified, 211–213
- Three-dimension (3D)  
 CAD systems, 17–18  
 illustrations  
   isometric projection, 81–85  
   oblique projection, 85–89  
 modeling, 395
- 3D annotation, 395  
 axis feature, 397–398  
 direction of tolerance zones, 401  
 of drawings, 396f–397f  
 median feature, 397–398  
 projected tolerance zone, 398  
 tolerance zone between two points, 399–400  
 unequal profile tolerance, 400  
 unilateral profile tolerance, 400
- 3D models, 1, 43
- 3D printing (3DP). *See* Additive manufacture (AM)
- 3D scale drawing, 43
- Thrust ball bearings, 533, 533f
- TIG. *See* Tungsten inert gas (TIG)
- TIME DELAY function (logic), 503, 503f
- TLD. *See* Top level directory (TLD)
- Toggle action, 146, 146f
- Tolerance zone, 298, 303  
 direction, 365  
 geometrical tolerancing, 302–303  
 3D annotation, 399–400  
 between two points, 329
- Tolerances, 281, 295  
 in ball and roller bearings, 537  
 characteristics, 418, 419t–420t  
 frame and feature, 298–300  
 geometrical, 293  
 position of remarks, 300  
 positional, 294, 307  
 restricted length, 301
- Tolerancing principle, 417–418
- Toolbox drawings, 264–267, 269f, 277f
- Tooling and CAD, 17–18
- Tooth width, 433
- Top level directory (TLD), 20
- Torsion springs, 451–452
- Total run-out, 338–339
- Toughened acrylics, 552
- TPD. *See* Technical product documentation (TPD)
- Trademarks, 32–33
- Trammel method for ellipse, 132–133, 132f
- Transition fit, 281, 282f
- Transition pieces and rectangular ducts, 177
- Triangular prisms, 176
- Trouble-free bearing operation, 545
- True length, 147, 168, 177  
 isometric view of rectangular block, 147f  
 lamina development, 153  
 true shape projections of lamina, 152f
- True position  
 dimensions, 294  
 and TEDs, 365–366
- Tubular joints, 549, 551f
- Tungsten inert gas (TIG), 461
- Two foci method for ellipses, 133–134, 133f
- Two mating tapers dimension, 194–195
- Two parallel planes sections, 115, 117
- Two-circle method for ellipse, 131
- Two-dimensional drawings (2D drawings), 395
- 2D drawing packages, 36–37
- Typefaces, 32

**U**

UNC. *See* Unified coarse pitch thread (UNC)  
Unequal profile tolerance, 400  
UNF. *See* Unified fine pitch thread (UNF)  
Unidirectional dimension, 191  
Unified coarse pitch thread (UNC), 211  
Unified fine pitch thread (UNF), 211  
Unified system of screw threads, 211  
Unified threads, 211–213  
Uniform acceleration and cam follower, 423, 423f  
Uniform velocity and cam followers, 422–423  
Unilateral limits, 284, 284f, 297  
Unilateral profile tolerance, 400  
Unregistered design rights, 30–32  
UV curing acrylics, 552

**V**

V-ring seal, 541–542  
Vacuum deposited coating, 387  
Vat Polymerisation process, 586  
Vertical plane (VP), 53, 53f  
‘Views’, 259  
Visualization, 45  
Volumes of revolution and sheet metalwork, 42  
VP. *See* Vertical plane (VP)

**W**

Washers  
  dimensions, 222t  
  locking, 242f

shakeproof, 240  
spring, 221f, 240, 241f  
tab, 243, 244f  
Watt, James, 145  
Watt’s straight-line motion, 145, 145f  
Weld decay, 393  
Welding, 461  
  dimension, 468–469, 464t  
  with pressure, 461  
  types, 463, 463t–464t  
  welding symbols on drawings, 462–468, 463t–464t  
  arrow and position, 466t  
  with complementary information tail indication projection welding, 467f  
  elements, 465f  
  with reference to specific instruction, 468f  
  supplementary symbols, 465t

Whitemetals, 521–522  
Whitworth thread, 212–213  
Whole depth of tooth, 433  
Wing nuts, 237  
Wire forms for springs, 460  
Wire locking, 241–243  
Wiring diagrams, 475  
Woodruff keys, 255  
Works, 32  
Worm gearing, 443–444  
Wrapped bushes bearings, 521

**Z**

Zoom in CAD, 36